

# GRD-4200

## Electronic earthing system

- Zone 1, 2, 21, 22
- High quality electronic components
- High resistance to corrosion and extreme weather
- Safe and reliable over time



# GRD-4200 Electronic earthing system

The GRD-4200 series electronic earthing system ensures grounding of tankers and tank trucks during the transfer of flammable liquids, preventing the formation of electrostatic charges.

During the entire loading and unloading phase, the device checks that the equipotentiality of the earthing system is maintained.

In fact, the electronic system is equipped with a protection circuit that checks the resistance value and compares it to the set parameter and, if this value falls within the preset range, closes the electrical circuit between the two systems that are equipotential. Vice versa, it removes the operating consent from the loading pump and closes the loading valve.

The GRD-4200 electronic earthing system has obtained SIL (Safety Integrity Level) Level 2 certification in compliance with IEC-61508 and EN-50495 standards, which guarantees that the system is able to perform its safety function.

Cortem Group applies a tamper-evident holographic security label to its products, complete with a unique authentication numeric code, to combat the illegal sale of imitations and counterfeits, as well as guarantee the authenticity of its products. Failure to observe international standards creates serious risks for the environment and, above all, for the personnel who work with the systems on a daily basis.



## Sectors of application:



Petroleum refineries



Chemical and petrochemical facilities



Onshore facilities



Offshore facilities



Petroleum loading/unloading pontoons



Agribusiness facilities



Fuel storage facilities



100% produced by Cortem

## CERTIFICATION DATA

<b>Classification:</b>	Group II	Category 2GD		
<b>Installation:</b> EN 60079.14	zone 1 - zone 2 (Gas)	zone 21 - zone 22 (Dust)		
<b>Marking:</b>	CE 0722 Ex II 2(1) G - Ex d [ia Ga] ia IIB+H <sub>2</sub> T6 Gb			
	CE 0722 Ex II 2(1) D - Ex tb [ia Da] ia IIIC T85°C Db			
<b>Certificate:</b>	ATEX	CESI 04 ATEX 129		
	IEC Ex	IECEX CES 14.0035X	For all IEC Ex certification data, download the certificate from <a href="http://www.cortemgroup.com">www.cortemgroup.com</a>	
<b>Standards:</b>	CENELEC EN 60079-0: 2012, EN 60079-1: 2007, EN 60079-11: 2012, EN 60079-31:2009 and the European Directive 2014/34/UE. IEC 60079-0: 2011, IEC 60079-1: 2007, IEC 60079-11: 2011, IEC 60079-31: 2008 RoHS Directive 2002/95/EC.			
<b>Temperature class:</b>	85°C (T6)			
<b>Ambient Temperature:</b>	-20°C +55°C			
<b>Degree of protection:</b>	IP66			

# GRD-4200 Electronic earthing system



## MECHANICAL FEATURES

<b>Body and lid:</b>	Low copper content aluminium alloy
<b>Gasket:</b>	Acid, hydrocarbon and high temperature resistant silicone positioned between the body and the lid
<b>Certificate label:</b>	Riveted aluminium on lid
<b>Screws, bolts and nuts:</b>	Stainless steel
<b>Earthing screw:</b>	Stainless steel M6. Inside and outside the body and on the lid, complete with anti-rotation brackets
<b>Fastening brackets:</b>	Electrolytically galvanized steel
<b>Lever on lid:</b>	In coated aluminium
<b>Warning lights:</b>	Impact and UV resistant polycarbonate
<b>Coating:</b>	Polyester RAL 7035 (Light grey)
<b>Resistenza alla corrosione:</b>	The STANDARD of the aluminium alloy used by Cortem has passed the tests required by standards EN60068-2-30 (hot-humid cycles) and EN60068-2-11 (salt fog test)
<b>Inputs:</b>	2 threaded holes 3/4" NPT. Complete with a PLG2N plug
<b>Cable gland:</b>	For non-armored cable, internally sealed, thread 3/4" NPT
<b>Cable:</b>	Yellow with trim in rubber resistant to oil and chemical substances. Suitable for extremely high mechanical stresses. Length 8 m.
<b>Plier:</b>	Bipolar, casting with aluminium with handles in neoprene, jaws with steel tips, auto-releasing. 16 mm opening.
<b>Bracket for plier:</b>	In stainless steel.

## ELECTRICAL FEATURES

<b>Rated voltage:</b>	230 Vac o 110 Vac o 24 Vac dc
<b>Rated frequency:</b>	max. 50/60 Hz

GRD-4200		
Status:	Block	Consent
Current draw:	12 mA	24 mA
Power:	1.64 W	4.32 W
Power factor:	0.57	0.82

GRD-4200/110		
Status:	Block	Consent
Current draw:	22 mA	45 mA
Power:	1.52 W	4.18 W
Power factor:	0.62	0.84

GRD-4200/24				
Status:	Block		Consent	
	24 Vac	24 Vdc	24 Vac	24 Vdc
Voltage:	24 Vac	24 Vdc	24 Vac	24 Vdc
Current draw:	64 mA	24 mA	64 mA	24 mA
Power:	1.64 W	4.32 W	1.64 W	4.32 W
Power factor:	0.57	0.82	0.57	0.82

## ACCESSORIES UPON REQUEST / SPECIAL REQUESTS

Cable gland  
Pliers PMT-B2

# GRD-4200 Electronic earthing system

## DIMENSIONAL DRAWING

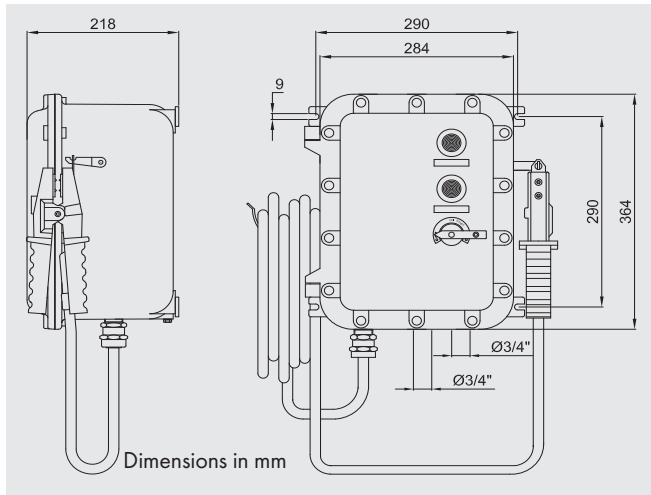

Detail of connection pliers

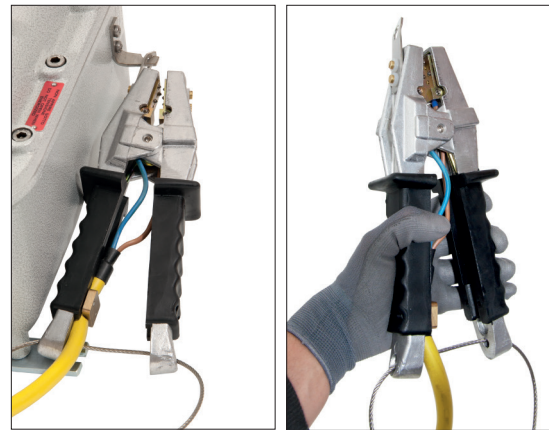

## SELECTION TABLE

Code	Power supply	Rated frequency	Weight Kg
GRD-4200	230 Vac	50 - 60 Hz	20
GRD-4200/110	110 Vac	50 - 60 Hz	20
GRD-4200/24	24 Vac dc	0 / 50 - 60 Hz	20

## ELECTRICAL WIRING

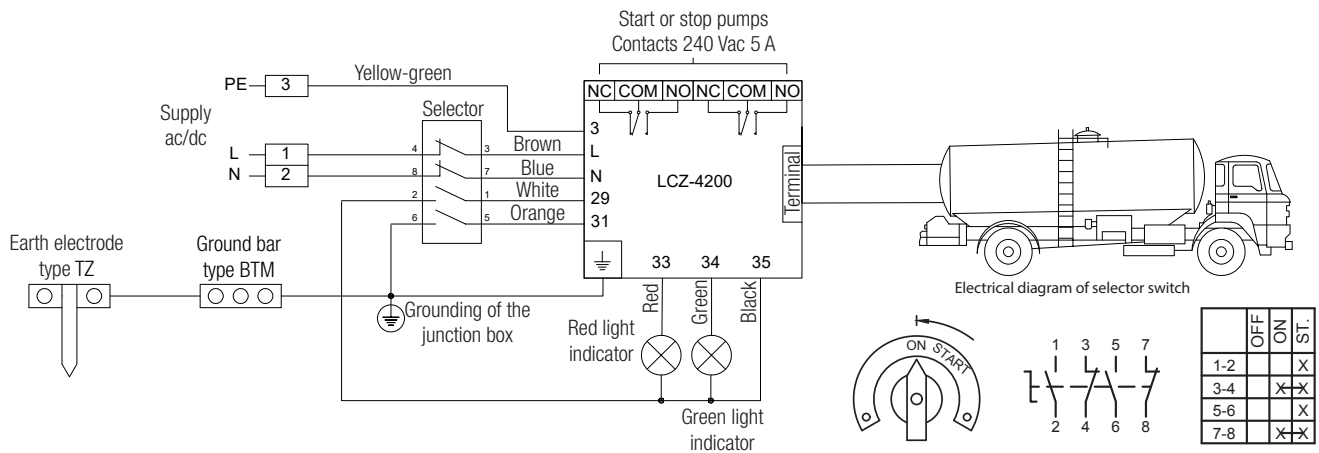

ILLUSTRATION	DESCRIPTION	MODEL	CODE	LEGEND
	Special switch	GRD...	SEA10X2/12EZ16R	
	Monitoring logic	GRD-4200	LCZ-4200	
		GRD-4200/110	LCZ-4200/110	
		GRD-4200/24	LCZ-4200/24	
	Earthing pliers	GRD...	PZCC-4209	
	Yellow cable Length: 8 metres	GRD...	NSSHOU-02X2,5	
	Barrier cable gland	GRD...	NAVB2NB	