

EXIT-P

- Zone 1, 2, 21, 22
- Group IIC
- LED lighting
- Polyester resin casing
- Transparent polycarbonate diffuser



EXIT-P Emergency lighting fixture

EXit-P is an emergency LED lighting device made of fibreglass-reinforced polycarbonate resin, designed for use in various configurations and classified environments with potentially explosive atmospheres. It is available in two versions: EXit-PE, suitable for installation in zones 1, 21, 2 and 22, and EXit-PN, for zones 2 and 21. The device has a power consumption of 8 W and can be configured in three different operating modes: normal mode, in which the LED strip light is powered exclusively by the LED driver; emergency mode, in which the LED strip light is managed solely by the emergency module, which uses a battery pack as a power source in the event of a power failure; and combined mode (normal + emergency), in which the LED strip light is controlled by the LED driver during normal operation and by the emergency module in the event of a power failure. The device can be fitted with an external LED indicator light for signalling the battery charge status. In EXit-PE versions, the LED driver and the emergency module are suitable for use in zone 1, thanks to Ex mb protection, while the LED strip light is protected with an Ex mb rating. In EXit-PN versions, the lighting fixture has Ex nR protection, which allows the device to be used in zone 2 without the need for additional specific protection for the LED strip light and internal electrical components. All versions have Ex tb protection so can be used in zones 21 and 22 thanks to an IP66 degree of protection, which guarantees a perfect seal against the penetration of dust or high-pressure water jets. These features make EXit-P a reliable and versatile solution for emergency lighting in industrial settings in the presence of explosive gas or dusts.

Sectors of application:



Petroleum refineries



Chemical and petrochemical facilities



Tanker loading / unloading areas



Tanker loading / unloading areas



Passage-ways



Emergency exits



Stair handrails



Perimeter zone lighting

CERTIFICATE DATA

Classification:	Group II	Category 2GD		
Installation: EN 60079.14	zone 1 - zone 2 (Gas)	zone 21 - zone 22 (Dust)		
Marking:	CE 0722 Ex II 2GD Ex db eb mb IIC T.. Gb - Ex tb IIIC T..°C Db IP66			EXIT-PE
	CE Ex II 3G - Ex nR IIC T.. Gc CE 0722 Ex II 2D - Ex tb IIIC T..°C Db - IP66			EXIT-PN
Certificate:	ATEX	CML 23 ATEX 1287X	EXIT-PE	
	ATEX	CML 23 ATEX 4289X	EXIT-PN	
	IEC Ex	IECEX CML 23.0107X	For all IEC Ex and UKEX certificate data, download the certificate from www.cortemgroup.com	
	UKEX	AVAILABLE		
Standards:	<p>CENELEC EN 60079-0: 2018, EN 60079-1: 2014, EN 60079-7: 2015+A1:2018, EN 60079-15: 2010, EN 60079-18: 2015+A1: 2017, EN 60079-31: 2024 and EUROPEAN DIRECTIVE 2014/34/EU IEC 60079-0: 2017, IEC 60079-1: 2014, IEC 60079-7: 2015+A1: 2017, IEC 60079-15: 2017, IEC 60079-18: 2014+A1: 2017, IEC 60079-31: 2022 European Directive 2004/108 Electromagnetic compatibility European Directive 2012/19/UE, 2002/96/CE, 2003/108/CE RAEE European Directive 2011/65/UE RoHS</p>			
Temperature class:	For all permitted ambient temperature classes, please see the "Selection tables"			
Ambient temperature:	-60°C for models with a battery -20°C for versions with an internal battery		For all permitted ambient temperature ranges, please see the "Selection tables"	
Degree of protection:	IP66			

EXIT-P Emergency lighting fixture

EXIT-P...



EXIT-P...-RI



For more information on electrical connectors see link:

www.cortemgroup.com/fastex-m



ORIGINAL PRODUCT

MECHANICAL FEATURES

Body:	GRP, black shock and UV resistant fibreglass reinforced polyester resin
Diffuser:	Transparent polycarbonate, shock and UV resistant
Gasket:	Silicone resistant to acids, hydrocarbons and high temperatures
Screws, bolts and nuts:	Stainless steel
Mounting:	Polyester feet for M6 screws
Entry points:	2 entry points Ø20.5 (suitable for ISO threads M20x1.5). Fixture complete with 1 PLG11LXE7 plug and 1 NAVP20IXE cable gland for non-armored cable

ELECTRICAL FEATURES

Autonomy in emergency mode:	1.8 Ah: 1.5 hours
Rated voltage:	Normal operation only: 220-240 Vac Emergency operation only: 110-277 V AC Normal + emergency operation: 220-240 Vac
Rated frequency:	50/60 Hz
Connection:	Directly to the terminal board L, N, Pe cross sec. 4 mm ² , jumpered terminal board suitable for in-out
Emergency unit:	Electronic inverter 110/277 Vac 50/60 Hz, 110-277 Vdc. Batteries Ni/Mh
Charge level:	LED indicator light showing the battery charge (pilot line ON) level for emergency versions.

NOTE: the technical and electrical data may change without prior warning owing to continuous developments in LED technology.

ACCESSORIES UPON REQUEST / SPECIAL REQUESTS

- Additional cable gland for in-out connection.
- Pictogram on request.
- Autonomy in emergency mode: 3 hours. (example code: EXIT-P..0308N3).

EXIT-P Emergency lighting fixture

DIMENSIONAL DRAWING

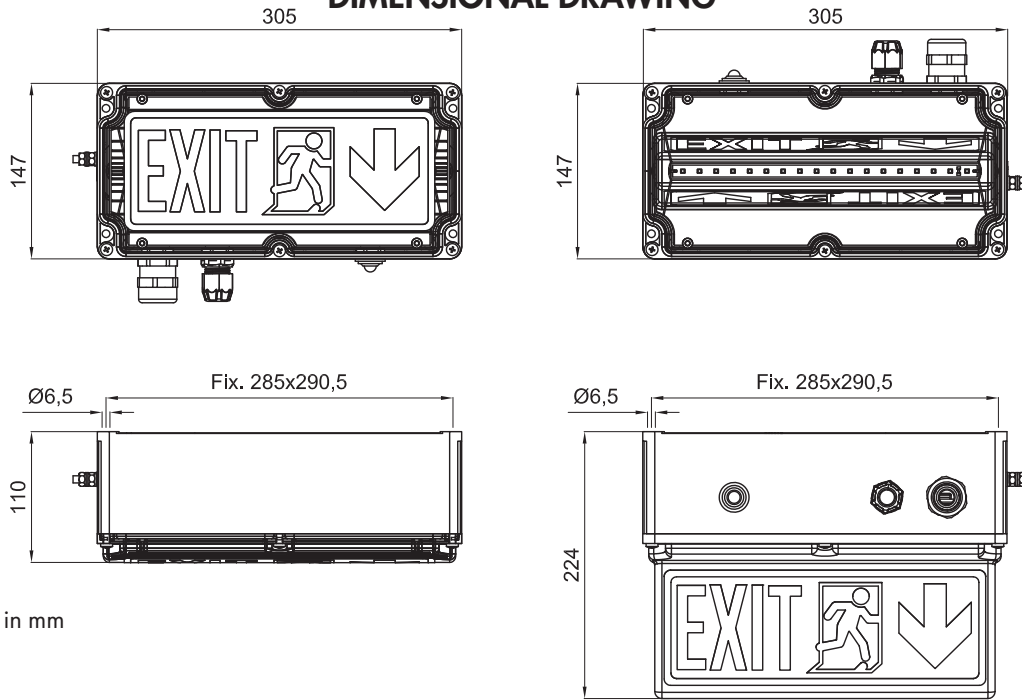

Dimensions in mm

Selection tables.

Temperature classes and maximum surface temperatures.

Code	Rated power Watt	Temperature class / Maximum surface temperature				Lumen lm	Type	Weight kg	mm
		TA=+40°C	TA=+50°C	TA=+55°C	TA=+60°C				
EXIT-PE-0308	8	T6 / 42°C	T6 / 52°C	T6 / 57°C	T5 / 62°C	805	Version without battery (-60°C)		
EXIT-PE-0308N	8	T6 / 42°C	T6 / 52°C	T6 / 57°C	T5 / 62°C	805 (586*)	Version with battery (-20°C)	848x118x159	
EXIT-PE-0308E	3	T6 / 42°C	T6 / 52°C	T6 / 57°C	T5 / 62°C				

* Lumen in emergency operation.

Selection tables.

Temperature classes and maximum surface temperatures.

Code	Rated power Watt	Temperature class / Maximum surface temperature				Lumen lm	Type	Weight kg	mm
		TA=+40°C	TA=+50°C	TA=+55°C	TA=+60°C				
EXIT-PN-0308	8	T6 / 42°C	T6 / 52°C	T6 / 57°C	T6 / 62°C	805	Version without battery (-60°C)		
EXIT-PN-0308N	8	T6 / 42°C	T6 / 52°C	T6 / 57°C	T6 / 62°C	805 (586*)	Version with battery (-20°C)	848x118x159	
EXIT-PN-0308E	3	T6 / 42°C	T6 / 52°C	T6 / 57°C	T6 / 62°C				

* Lumen in emergency operation.

EXIT-P Emergency lighting fixture

ORDER CODE LOGIC

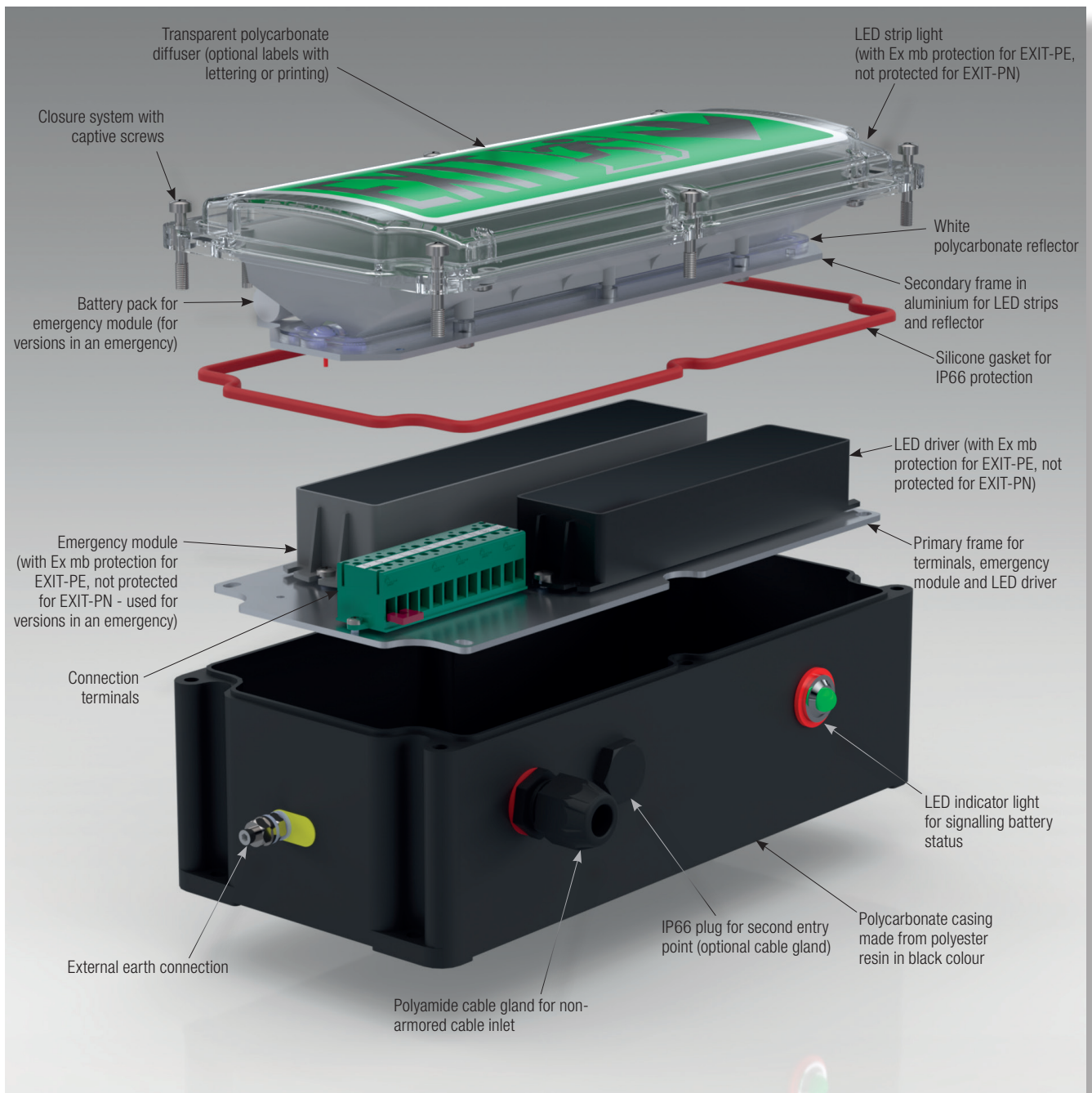
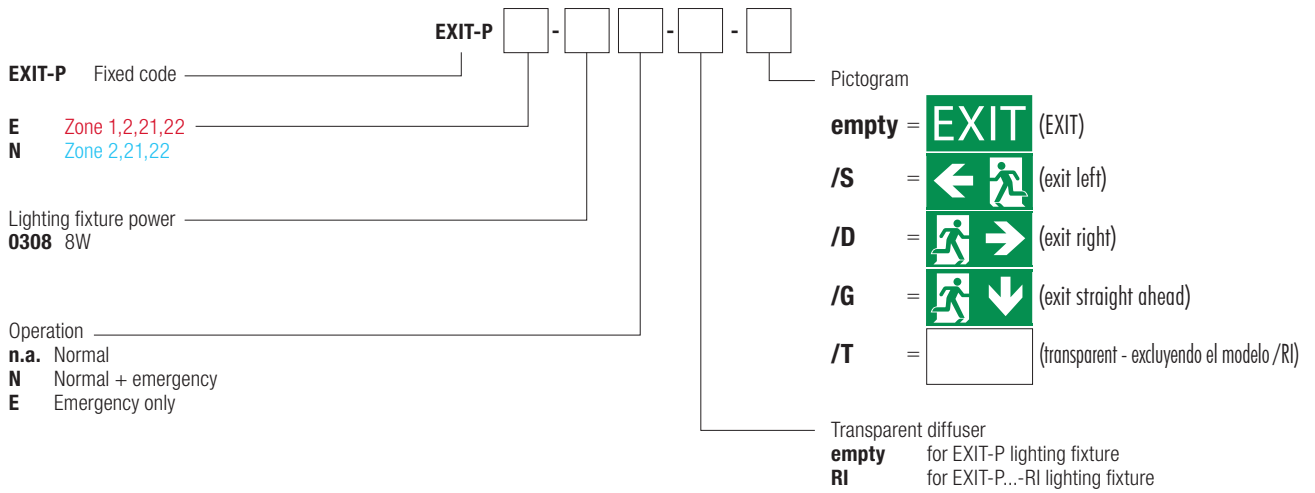

EXIT-P Emergency lighting fixture

ILLUSTRATION	DESCRIPTION	MODEL	FEATURES	CODE	KEY
	Transparent diffuser suitable for EXIT-P series fixtures	EXIT-P..	Transparent polycarbonate	G-1309 G-1309/S G-1309/D G-1309/G G-1309/T	
	Transparent diffuser suitable for EXIT-P...-RI series fixtures	EXIT-P...-RI		G-1309/RI G-1309/RI/S G-1309/RI/D G-1309/RI/G	
	Battery	EXIT-P..	NiMH, 1.8Ah: 90min NiMH, 3Ah: 180min	G-1096/B G-1097/B	
	Resin electronic power unit	EXIT-PE..	LED driver Ex mb	EBM-30L/350	
	Electronic power unit	EXIT-PN..	LED driver	LEDDLIFEX10	
	Fibreglass inverter	EXIT-PE..	Inverter Ex mb	EIM-30L/1	
	Inverter	EXIT-PN..	Inverter LED	INVERTER/LED/NM/1	
	Single LED		Colour: green	M-0487V/920	
	O-ring between body and lid		Material: red silicone	B-279S	
	Polyamide cable gland	EXIT-P..	For cable gland models and codes, please see www.cortemgroup.com	NAV20IXE	