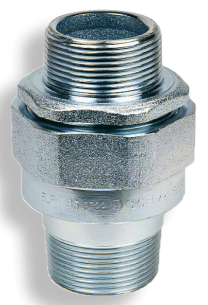
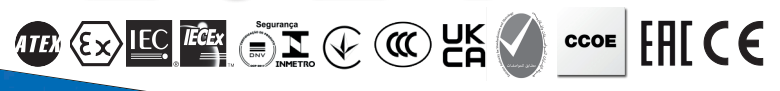


PRESSACAVI e RACCORDERIA  
per impianti elettrici  
PRESSACAVI e RACCORDERIA  
per impianti elettrici

2024

**ELFiT**<sup>®</sup>

Electrical FITtings



per impianti elettrici





# **ELFIT**<sup>®</sup>

**Electrical FITtings**



## Electrical connectors

FASTEX-M Electrical connectors .....	A.2
--------------------------------------	-----

## Cableglands Ex-proof

Cable gland series NAV for non-armoured cables from 1/4" to 4" .....	B.2
Cable glands series NAVF for non-armoured cable with female entry.....	B.4
Cable glands series NAVN for non-armoured cable with male entry.....	B.6
Cable glands series NAVFS for non-armoured cable with "swivel" female.....	B.8
Cable glands series NAVNS for non-armoured cable with "swivel" male.....	B.10
Cable gland series NEV for armoured cables from 1/4" to 4" .....	B.12
Cable gland series NEVL for lead sheathed armoured cables.....	B.14
Accessories and technical specifications of the NAV series cable glands.....	B.16
Cable gland series NAVB for non-armoured cables from 3/8" to 4" .....	B.20
Cable gland series NAVBF for non-armoured cables from 3/8" to 4".....	B.22
Cable gland series NAVBN for non-armoured cables from 3/8" to 4" .....	B.24
Cable gland series NAVGB for non-armoured cables from 3/8" to 4".....	B.26
Cable gland series NEVB for armoured cables from 3/8" to 4" .....	B.28
Cable glands series NAVP in polyamide for non-armoured cable .....	B.30

## Electrical fittings for electrical plants

BMF three pieces unions Fixed male/Turning female - IIB.....	C.2
BFF three pieces unions Fixed female / Turning female - IIB.....	C.4
BMM three pieces unions Fixed male / Turning Male - IIB.....	C.6
RBMF three pieces unions Fixed male / Turning Female - IIB high temperatures.....	C.8
RBFF three pieces unions Fixed female/Turning female - IIB high temperatures.....	C.10
RBMM three pieces unions Fixed male / Turning male - IIB high temperatures.....	C.12
RMF three pieces unions Fixed male/Turning female - IIC.....	C.14
RFF three pieces unions Fixed female/Turning female - IIC.....	C.16
RMM three pieces unions Fixed male/Turning male - IIC.....	C.18
RE male - female adaptors.....	C.20
Adaptors REB female - male.....	C.22
Adaptors REM female - female.....	C.24
Adaptors REN male - male.....	C.26
PLG male close-up plugs with conical thread.....	C.28
PLG male close-up plugs with cylindrical thread.....	C.30
PLG.7 polyamide close-up plugs with cylindrical thread.....	C.32
ELF - ELMF - ELM 90° elbows.....	C.34
EM couplings.....	C.36
Resin-filled sealing fittings and drain valves features.....	C.38
CRV420 sealing compound.....	C.38
FV... Glass fiber.....	C.39
EYS Vertical sealing fittings.....	C.40

# PRODUCT





EYD vertical sealing fittings .....	C.41
EZS horizontal sealing fittings .....	C.42
ECD drain and breather valves .....	C.44
NPS sealing nipples .....	C.46
NPS sealing nipples .....	C.47
TP sealed bushings for multicables with a threaded joint .....	C.48
CP sealing bushings for multicables with cylindrical joint .....	C.49
Maximum quantity and wires type tables .....	C.50
SP flexible conduits .....	C.52
ESP flexible conduits .....	C.54
LBH open elbows .....	C.56
LBHS open elbows .....	C.57
EKC Pulling boxes .....	C.58
BC rigid conduits .....	C.59
DB...A aluminium bushing .....	C.60
DB...P polypropylene bushings .....	C.60
DBT aluminium bushings with earth screw .....	C.61
MC female closing plugs .....	C.61
DL metal locknuts .....	C.62
DL...P polyamide locknuts .....	C.62
MT conduit clamps .....	C.63
UBD U-bolts .....	C.63
GF saddles .....	C.64
MP conduit clamps .....	C.64
Electrowelded collar CST .....	C.65

## Junction and pulling boxes

S series junction and pulling boxes .....	D.2
---	-----

## Weather proof series

CS, CSG series aluminium junction boxes .....	E.2
CS/P series polyester junction boxes .....	E.4
CS/SS series stainless steel junction boxes .....	E.6
CTBEW series stainless steel junction boxes .....	E.8
7 series pulling boxes (CONDULET) .....	E.10
Appendix .....	F.1

# PRODUCT





# INTRODUCTION

## FROM CABLE GLANDS TO ELECTRICAL FITTINGS FOR ELECTRICAL PLANTS

1

Elfit S.p.a.:  
the value of  
experience



**Fig. 1e 2** Elfit's plant at the beginning of 80's

**D**uring the '70s, **Elfit** company was established in order to carry out some strategic internal processes of Cortem and to provide the market with complementary lighting products, such as electrical equipment, cable glands and junction boxes. Thanks to its reliability and the service offered, it becomes an important player of Oil&Gas field with a highly qualified brand, both in Italy and internationally. Due to a continuous improvement of technology and investments, Elfit is specialized in foundry, mechanical workshop and in the manufacturing of explosion and weather proof cable glands, junction boxes and electrical fitting.





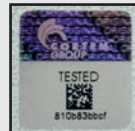
To be sure to be safe.



Today Elfit, along with Cortem and Fondisonzo brands, forms **Cortem Group**, one of the main international leader of Oil&Gas for the explosion-pro- of field. The peculiarity of Cortem Group is the experience gained in almost 50 years of activity in the Ex field which results not only in the supply of simple Ex-products, but also in customized solutions.

Cortem Group's products are available in different executions, "Ex d", "Ex e", "Ex de", "Ex i", "Ex n", "Ex t", and are manufactured using low copper alu- minium alloy, stainless steel and plastic materials which ensure strenght and duration over the time.

Their autenticity is guaranteed by the application of an adhesive label with a 3D matrix, an alphanumeric code and a QR code for smartphone readers, that protect the product from fakes. The alphanumeric code can be verified on the [www.cortemgroup.com](http://www.cortemgroup.com) website.



**Fig.3**  
Above, Cortem Group's plant today

**Fig.4 e 5**  
Above and on the left, the modern production technologies of Cortem Group







**Fig.6**  
Products' certificates



Cortem Group electrical equipment are certified in accordance with the European standard ATEX, the International regulation IEC Ex, also obtained the regulatory compliance to INMETRO standard for Brazil and TR CU standards for the Eurasian Customs Union. Respecting these strict international construction rules, guarantees the safety of people and environment.

Cortem Group manufactures its products using modern processes, plants and qualified personnel. The quality management system conforms to UNI EN ISO 9001:2015 standard.

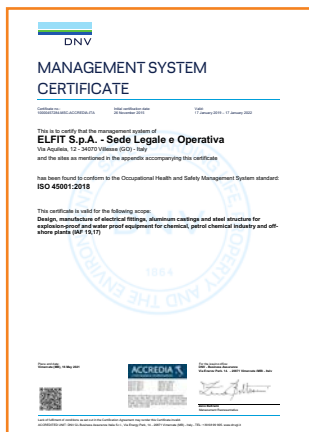
Furthermore, Cortem Group has developed an Occupational Safety and Health Management System certified according to OHSAS 18001:2015 Standard.

The Elfit production included in this catalogue can be summarized in the following macro-categories:

1. Ex-proof cable glands with compression ring and barrier cable glands for armoured and non-armoured cable; plastic cable glands for non-armoured cables and other applications.
2. Electrical fittings: three pieces unions, adaptors, closing plugs, available with different threads and methods of protection, 90°elbows, open elbows, couplings, sealing fittings and pulling fittings, rigid and flexible conduits.
3. Ex-proof junction boxes and pulling boxes.
4. Weather-proof pulling boxes and cable glands.



**Fig.7**  
Management system certificates





If we go back in time to the end of the first half of the last century, electrical systems suitable for hazardous areas were mainly realized in conduit "Freez moon" type and the ending on the input/output of flameproof enclosures were realized with sealing fittings next to the boxes (the old standard CEI 64-2 said that sealing fittings had to be positioned at a maximum distance of 450mm and only one joint was allowed between two enclosures with a distance not higher than 900mm).

This technique, still required today for some particular cases, except that distances have to be in compliance with the current standard EN 60079-1, had the disadvantage of having to cut the cable in case of reinstatement, with economical increases due to the impossibility to recover the cable because it is sealed into the sealing fitting.

The coming of cable gland has radically changed the plant approach, firstly simplifying the installation (image the difficult to align input/output conduits with entry/exit from junction boxes) and then giving the possibility to recover the cable in case of reinstatement.

Since the beginning of its activity, Elfit has been realizing products in compliance to current standards and in order to be used with a wide range of cables both armoured and non-armoured.

The cables usually used in on-shore and off-shore plants are divided in:

- non-armoured cables in PVC, for fixed sediment, with insulation class 0,6/1kV;
- insulated cables with wireframe ethylene propylene (EPR) or (XLPE), insulation class 0,6/1kV;
- armoured steel wire (SWA) or armoured aluminium wire (AWA).

In a first production phase, cable glands were realized with a sealing rings kit due to manufacturing characteristic of these cables with different diameters that change from manufacturer to manufacturer.

Anyway, this solution caused a waste of spare materials because the exact diameters of cables are not usually available during the design phase.

To avoid the unused and the consequent waste of sealing rings, Elfit focuses its research activity towards the optimization of those gaskets.

The cable glands series features only one sealing ring suitable to the variables of cables size, both armoured and non-armoured. Moreover, it provides only one opening key that simplifies the assembly.

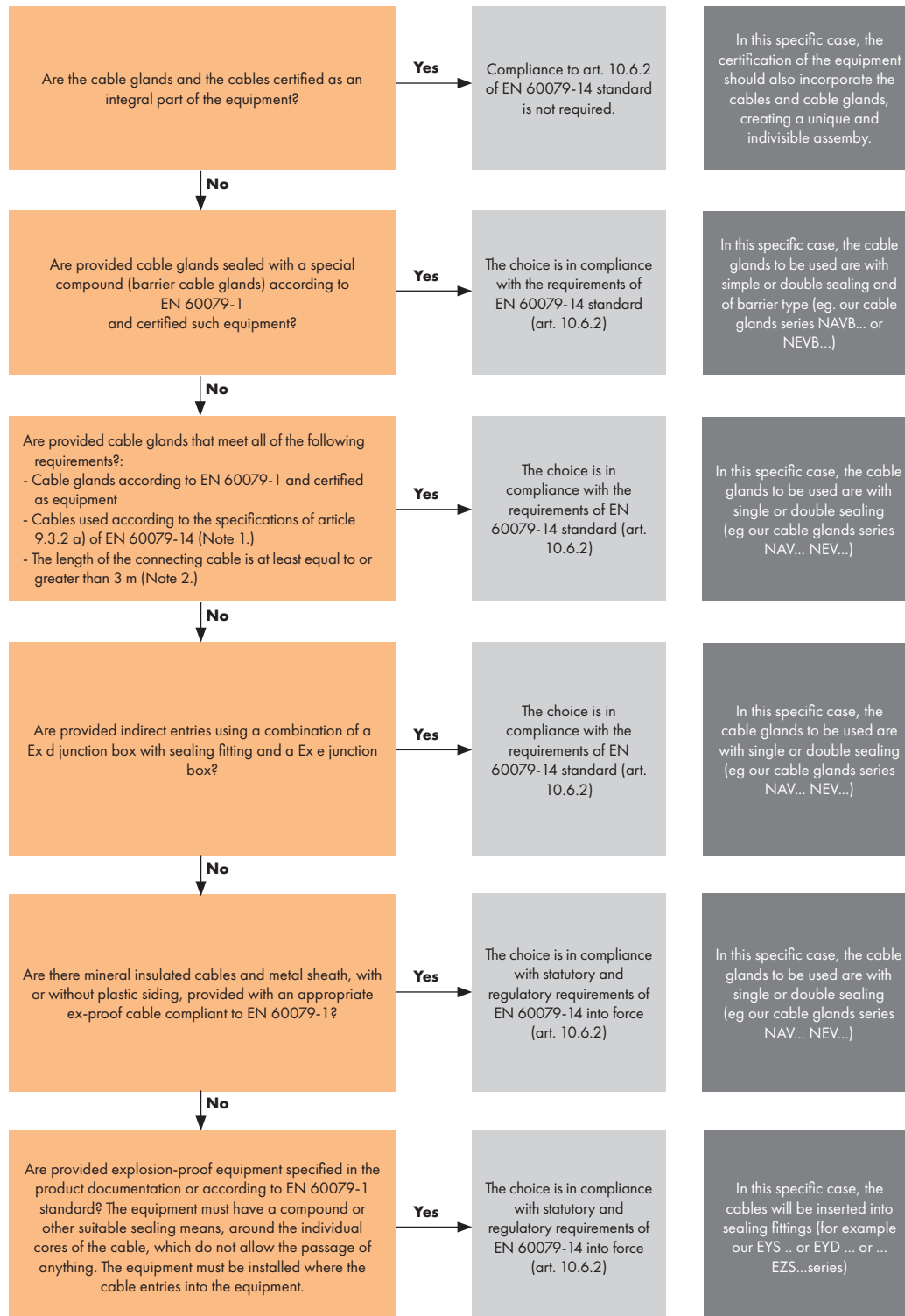
This new series has successfully got the product certification by international licensed authority.

Current standards relevant to products suitable to be installed in hazardous areas have settled a method to carry out plants that simplifies mounting and maintenance operations, always respecting what is defined by the standards.

## **2.1 THE SELECTION OF CABLE ENTRY SYSTEMS IN EXPLOSION-PROOF JUNCTION BOXES**

The selection of the cable entry in explosion-proof junction boxes must comply with the requirements of EN 60079-14 standard and in particular:

- Cables with sheaths with low tensile strength, known as "easy tear", must not be used in areas with risk of explosion if not installed in protective conduit. Thermoplastic wire of the type in polyvinyl chloride (PVC) with a tensile strength of 2.5 N / mm<sup>2</sup>; in polyethylene with a tensile strength of 15.0 N / mm<sup>2</sup> and cables in elastomeric polychloroprene or chlorosulfonated or polyethylene or similar polymers with a tensile strength of 15.0 N / mm<sup>2</sup>, are commonly classified as "easy tear".
- The cables for fixed installations must be suitable to the environmental conditions and must be sheathed in thermoplastic, thermosetting or elastomeric material and mineral insulated metal sheathed.
- When there is the possibility of gas or vapour transfer through the interstices between the conductors of a cable, to a non-hazardous area or to a different hazardous area, the construction and the use of the cable must be designed so that to avoid the flame propagation (See Note 2 in Figure 8).
- When it is not applicable as described in paragraph above, must be used mineral insulated cables, with sealing, for example our barrier cable glands series NEVB ...
- The cable glands must be properly selected depending on the specific cable diameter. It is not allowed the use of sealing tapes, thermo-tightening sheath or other materials such as fillers for the achievement of the sealing diameter on the cable gland.
- The choice of the cable glands must comply with the provisions of Section 10.6.2 of EN 60079-14 which are summarized in the flow, in Figure 8.



**FIG.8** Flow chart for the correct selection of the cable entry in Ex d junction boxes

INTRODUCTION FROM CABLE GLANDS TO ELECTRICAL FITTINGS FOR ELECTRICAL PLANTS

Note 1. With a sheath in thermoplastic, thermosetting or elastomeric material. They must be circular and compact. Any padding or sheath must be extruded. Any fillers must be non-hygroscopic.  
 Note 2. The minimum cable length is defined in order to limit the potential danger due to the transmission of flame through the cable.



## 2.2 A COMPLETE RANGE OF SOLUTIONS FOR OIL&GAS APPLICATIONS

**INDUSTRIAL PLANTS WITH RISK OF EXPLOSION: CABLE GLANDS WITH COMPRESSION RING FOR ARMoured AND NON-ARMoured CABLE**



**NAV, NEV, NAVF, NAVN, NEVL, NAVFS, NAVNS SERIE**

**INDUSTRIAL PLANTS WITH RISK OF EXPLOSION: BARRIER CABLE GLANDS FOR ARMoured AND NON-ARMoured CABLE**



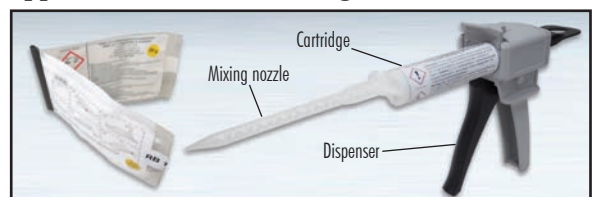
**NAVb, NAVbF, NAVbN, NEVb SERIE**



For armoured and non-armoured cable, protection method flame-proof "Ex db", increased safety "Ex eb", dusts protection "Ex tb", 'Ex nR' restricted breathing, Zone 1, 21, 2, 22, Gas group IIC, Dusts group IIIC, IP 66/67. They have only one sealing ring that guarantees explosion and IP protection, they are available with male and female threaded hub for armoured cables with lead sheath and for non-armoured flat/heating cables, optical fiber cables.



For armoured and non-armoured cable, protection method explosion-proof "Ex db", increased safety "Ex eb", protection against dusts "Ex tb", 'Ex nR' restricted breathing, Zone 1, 21, 2, 22, Gas group IIC, Dusts group IIIC, IP66/67. Barrier cable glands are supplied with a resin finishing kit:



Don't forget to order the resin kit with two-component resin:  
 - 25 ml resin bag code BOND-B-25  
 - 100 ml resin bag code BOND-B-100  
 - 40 ml cartridge + mixing nozzle code BOND-C  
 (manual dispenser supplied as an option code DISP-C)



**INDUSTRIAL PLANTS WITH RISK OF EXPLOSION: CABLE GLANDS FOR NON-ARMOURED CABLES IN HIGH RESISTANCE POLYAMIDE**



**NAV P SERIES**



For non-armoured cables, protection method increased safety "Ex eb", "Ex tb" for dusts, Zone 1, 21, 2, 22, Gas group IIC, Dusts group IIIC, IP66/68, ISO and PG threads. Cable glands are easy to install, impact resistant until 7J and guarantee Ex and IP protection on to the external sheath of the cable.





## 2.4 CABLE INSTALLATION AND CONDUIT INSTALLATION

It is important to check the match system between different enclosures that, contrary to industrial equipment (concerning standards EN 61439), requires to install specific sealed fittings between two junction boxes, so as to avoid the spread of a possible explosion that could accidentally occur in one of those enclosures.

As it is shown in the images sequence below reported, the lack of sealed fittings causes not only the passage of the explosion to the next enclosure, but it even generates an increase of the pressure originated from that explosion, with a consequent greater risk of damages to people.

The standard EN 60079-1, section 13.2.2, says "The distance from the face of the seal closest to the enclosure (or intended end-use enclosure), and the



outside wall of the enclosure (or intended end-use enclosure) shall be as small as practical, but in no case more than the size of the conduit or 50 mm, whichever is the lesser", so the sealed fitting should be installed next to the junction box, to give the right functional warranty, as specified on section 10.5 of Standard EN 60079-14 which says "A conduit sealing device is considered as fitted immediately at the entry of the flameproof enclosure when the device is fixed to the enclosure either directly or through an accessory necessary for coupling according to the manufacturer's instructions".

In the conduit installation, the electric cables run in a system of rigid conduits and enter explosion-proof boxes by means of sealed fittings. This avoids possible explosions to expand and spread inside the housings (Fig. 9). The outlet of every "Ex d" box features a sealed fitting which prevents explosions from spreading to other sections, delimits the volume of the "Ex d" electrical construction to a value close to that for which it has been proven, and separates the conduit installation from a possible part made with external cables.

In conduit installations, wires pass inside a threaded conduit "free moon"

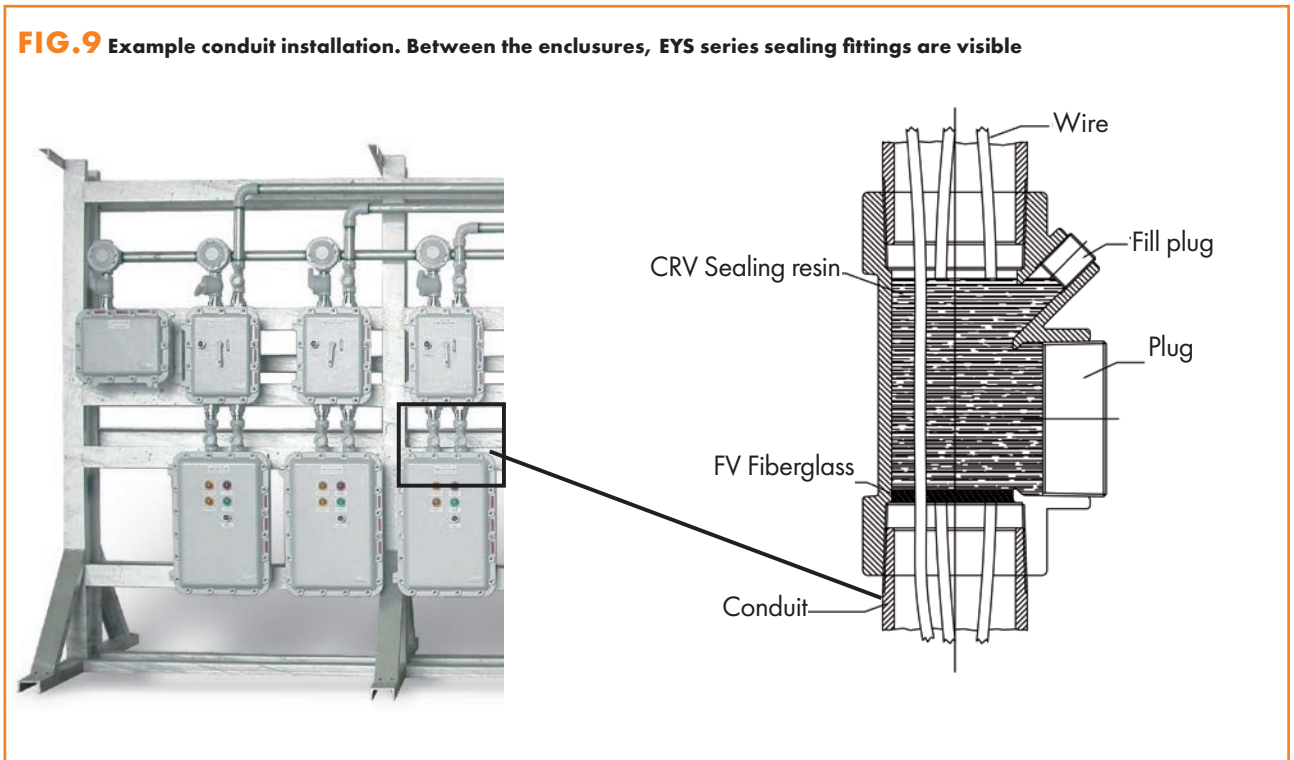
and though a sealed fitting; these sealed fitting must be filled with the right mixture of bi-component resin. This method effectively protects cables against mechanical and chemical damage. One disadvantage is that it is difficult to change the wiring later on.

On Fig. 9 there is an example of cable installation with mounting of sealing joints.

Cable installation, with use of specific cable glands, can be realized both with direct and indirect entry.

In the cable installation with direct entry, (Fig. 10) cable glands are restricted

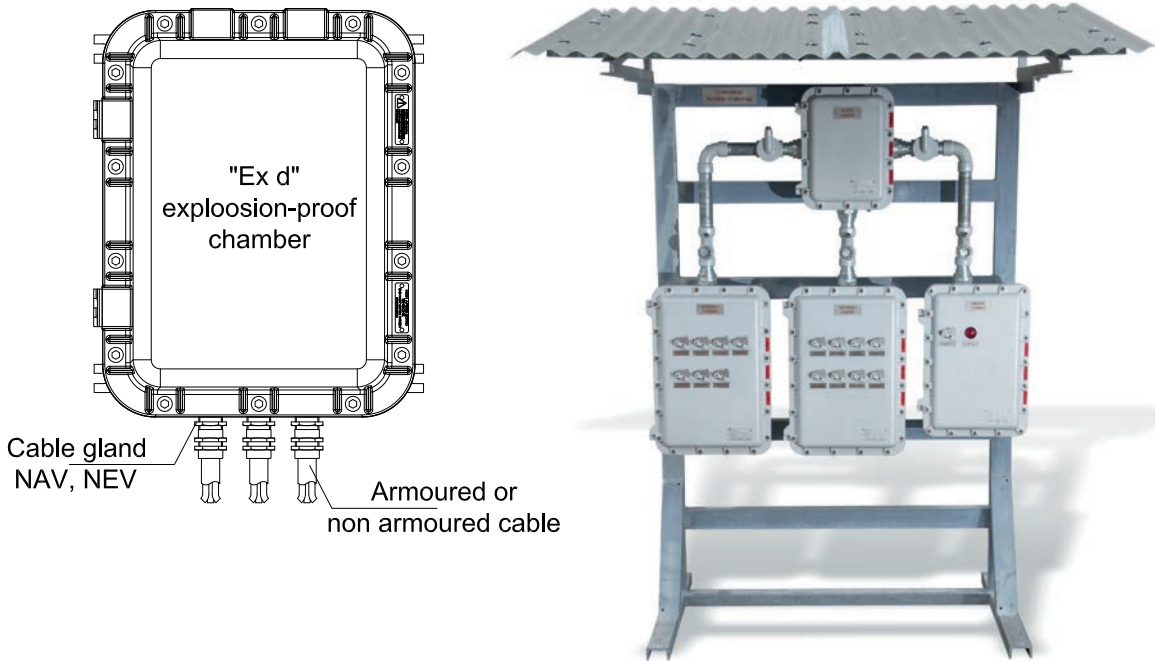
**FIG.9** Example conduit installation. Between the enclosures, EYS series sealing fittings are visible



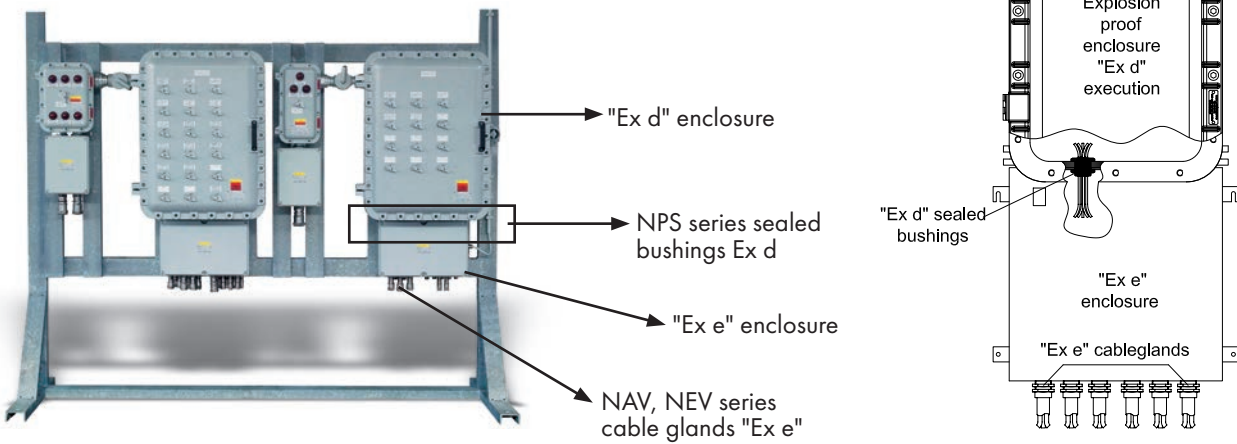
directly on one or more sides of the "Ex d" enclosure and, thanks to their peculiarity, they realize the same segregation degree of the sealed fitting with the advantage of being inspect (possible cable replacement).

In the cable installation with indirect entry, (Fig. 11) cable glands are increased safety "Ex e" type and tested on one or more sides of the enclosure in "Ex e" execution. By means of sealed bushings, the "Ex e" box is connected to the "Ex d" box.

**FIG. 10** Example of directly cable entry

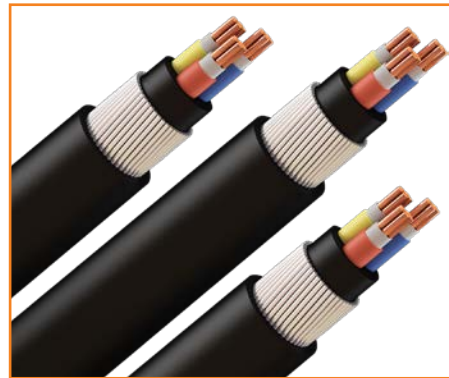
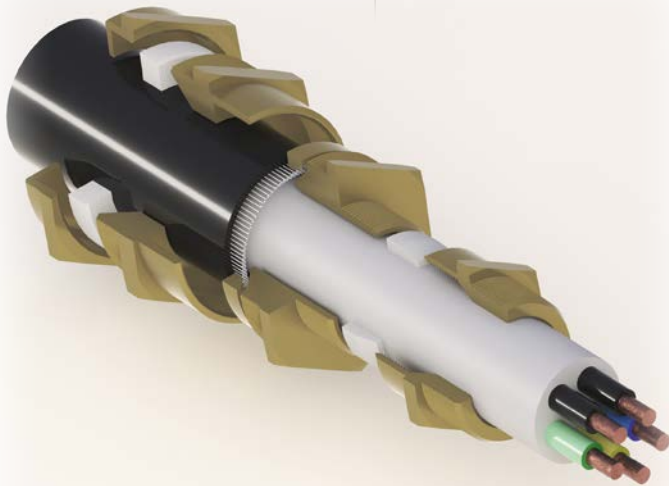


**FIG. 11** Example of indirect cable entry





## Type of electrical cables



Cables used for fixed installations in dangerous areas, under operating conditions (hot cables) must be suitable for the environmental conditions and must have the following features:

- be made of thermoplastic, thermosetting or elastomeric material, they must be circular and compact, any padding and sheaths must be extruded and any fillers must be of non-hygroscopic material;
- or they must be made with mineral insulation under metal sheath;
- or they must be of a special type, such as flat cables that must be coupled with cable glands suitable for such types of cables, having however the same constructive features as described above.

When there is a probability of gas or vapour transferring through the interstices between the individual cable cores and the cable leads to a non-danger-

**E**lectrical cables can be of two types: copper and aluminium made. When electrical cables and/or conductors are constructed of ropes or wire of aluminium, the terminal connections such as terminals or attacks of equipment, must be suitable for the coupling with aluminium in order to avoid electrolyte corrosion effects resulting from couplings with brass/aluminium or copper/aluminium.

Such aluminium cables and/or conductors, with the exception of intrinsically safe systems and with limited energy, must usually have a section not less than 16mm<sup>2</sup> and the connections must ensure that the distances of surface insulation and in the air are not reduced by the additional means required for connection.

Must not be used cables with traction strength of internal and external sheath less than 8.5 MPa. Cables with traction resistance lower to 8.5 MPa are commonly known as "easy tear" cables.

ous place or in zones with a different explosion hazard, the intended construction and use of the cable falls in the provision of paragraph 10.6.2, paragraph b)

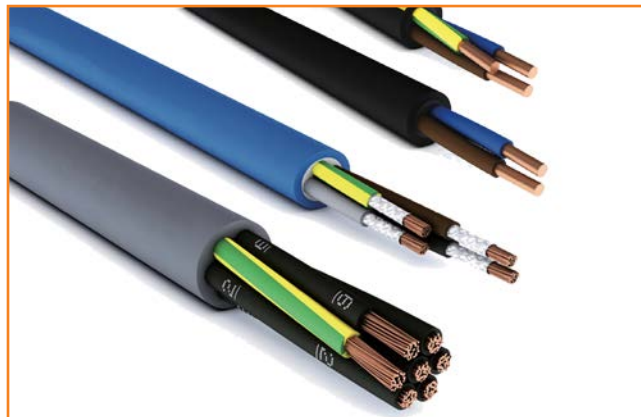
Flexible cables used for fixed installations in dangerous areas, with the exception of intrinsically safe cables, must be suitable for the environmental conditions and must have one of the following features:

of IEC/EN 60079-14.

- be made of hard rubber sheath for ordinary use;
- be made of polychloroprene sheath for ordinary use;
- be made of hard rubber sheath for heavy use;
- be made of polychloroprene sheath for heavy use;
- be made with thermoplastic insulation and of robust construction equivalent to the one of flexible cable with hard rubber sheaths for heavy use.

The cable temperature must never exceed the value of temperature relative to the specific Temperature Class assigned to the installation area for such cables.

All cables for fixed installation must have the characteristics of non-propagation of the flame, in agreement to IEC 60332-1-2 or IEC 60332-3-22 standard or to other kind of protection such as laying in sand filled tubs or using flame retardant barriers installed at the entrance of the cables in the classified area, in order to prevent the propagation of the flame and, consequently, an explosion.

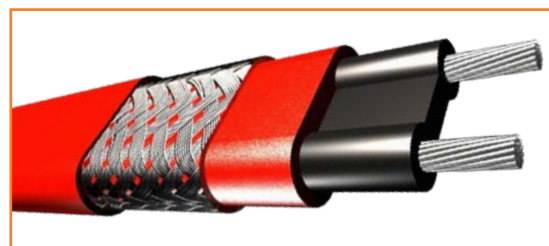


### 3.1 TYPICAL COMPOSITION OF ELECTRICAL CABLES

#### Premise

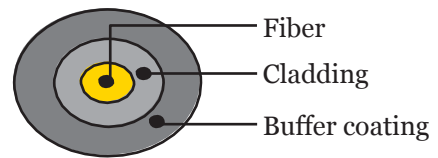
Here below we'll explain the typical cable formation, without getting into specifics of the constructive form which, referring to the paragraph 9 of 60079-14 standard, may be of different form and function, in relation to specific plant requirements. ELFIT, aware of these necessity, has created a series of specific accessories for the installation of cables such as:

- Flat cables, specific for handling and lifting systems of and suitable for transport systems for use in lifting systems, automated logistics and vertical storage systems, also suitable for use in cable chains for moving machines.



Example of heating cable

- Cables for transporting light signals (optical fibers). The transmission of a signal in fiber optic cables takes place through the principles of reflection and refraction of the light beam obtained by converting an electrical signal or pulse. The light beam that passes through the conductor, plastic or glass, is reflected (rebounds) with a certain angle of incidence on the cladding of the conductor called "cladding", inside the optical fiber. The goodness of the transmission over long distances will depend on the transparency and purity of the material constituting the optical fiber, hence the lesser refraction along the transmission line. In a time where the demand of fast and secure data networks is constantly growing, fiber optic cables are indispensable and irreplaceable. This type of cable is in fact better than the classic cables as it does not have the strand formation but it is like a single conductor.



### a) Primary insulation

#### *Cables with primary insulation in Polyvinyl Chloride (PVC)*

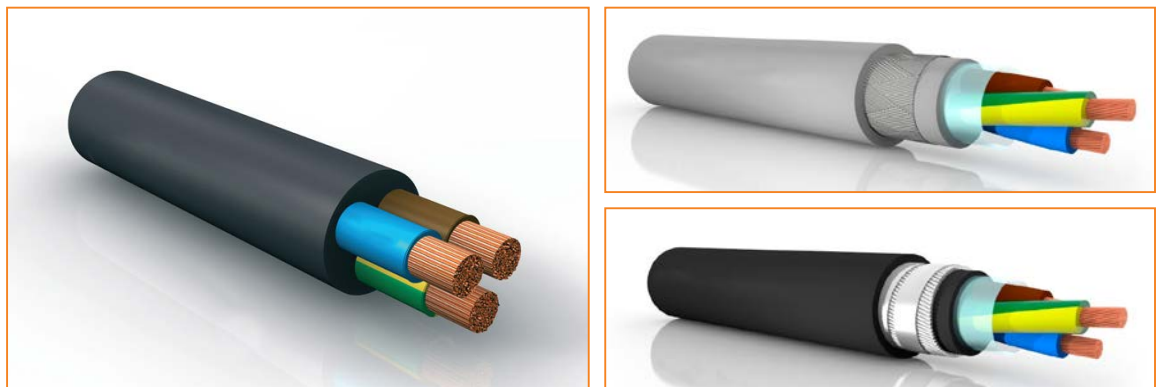
PVC is a versatile material that allows multiple content and different needs and it is the most commonly used for primary isolation in cables installed in generalized environments such as power supply utilities, signalling, lighting and, in general, all industrial electrical equipment.

Its operating temperature can range from 70° C to 125° C, depending on the different formulation of the compound used. The addition of special additives and plasticizers increases the strength of the compound at high temperature.

Special PVC with a higher oxygen index, are used in the case of compliance with non-propagating fire tests in accordance with standards CEI 20-22/2, CEI 20-2 /3, IEC 332.3A, IEC 332.3C.

#### *Cables with primary insulation in Polyethylene (PE)*

Polyethylene (PE) is the most commonly used material for primary insulation of coaxial radiofrequency cables, which, due to its low dielectric constant ( $\epsilon_r = 2.3$ ), it allows to produce low-capacity cables with speed of signal transmission which can also reach 0.8c (c = light speed)

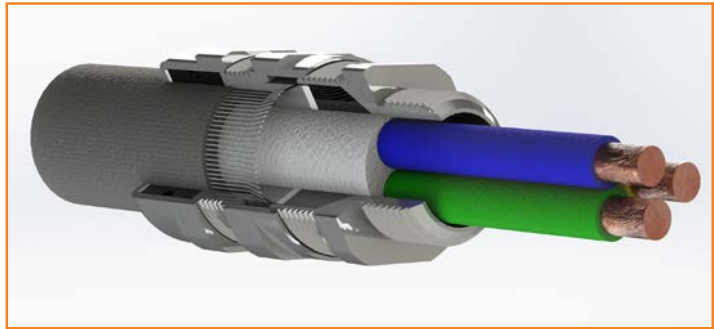




in the case of cellular polyethylene. Furthermore, the dielectric constant and the factor of loss are largely independent from temperature and frequency.

#### *Cables with primary insulation in cross-linked polyethylene (XLPE)*

The crosslinked polyethylene (XLPE) is used for the primary insulation of cables of low, medium and high voltage, for signalling and control cables. The crosslinking process improves the cracking resistance under stress, the cold resistance and, as it does not melt like an elastomer, it is able to withstand thermal loads up to 120° C.



#### *Cables with primary insulation in polypropylene (PP)*

Polypropylene (PP) is used for the primary insulation of telecommunication cables, telephony, data transmission which, as mentioned for cables in PE, thanks to its low dielectric constant ( $\epsilon_r = 2.3$ ), allows to realize low-capacity cables, with signal transmission speeds that can reach up to  $0.75 \div 0.8c$  ( $c$  = light speed), in the case of cellular polypropylene.

Furthermore, the dielectric constant and the loss factor are largely independent from temperature and frequency and, in comparison to polyethylene, the polypropylene is more rigid.

#### *Cables with primary insulation in Thermoplastic Rubber (TPE-O)*

Thermoplastic rubber (TPE-O) is used for primary insulation for cables installed in generalized environments such as power supply, signalling, lighting and, in general, for all the electrical equipment of industrial type, combining the performance of vulcanized rubbers such as heat and low deformation resistance and the ease of processing of thermoplastic materials.

This type of cable finds particular use as primary insulation for spiral and extensible cables, particularly in the automation sector where the flexibility is a key requirement.

#### *Cables with primary insulation in thermoplastic elastomer with polyester base (TPE-E)*

Polyester (TPE-E) is used for primary insulation of cables installed in generalized environments such as power supply, signalling, lighting and, in general, all industrial electrical equipment, when it is required good resistance to flex, abrasion, impact, even at very low temperatures, temperature peaks and to chemical and atmospheric agents.

### **b) Secondary coating (sheaths)**

With regard to PVC coating material, TPE-O and TPE-E, it's worth what written for primary isolation.

#### *Cables with polyethylene sheath (PE)*

Polyethylene is used as a secondary cable coating when it is required to lay it outdoors or in wet environments; in fact, this material has excellent resistance to water and salt solutions.

## *Cables with polyurethane sheath (TPE-U)*

Polyurethane is used as a secondary coating for cables when flexibility features are required in a wide range of temperatures, ranging from  $-40^{\circ}\text{C}$  to  $+100^{\circ}\text{C}$ , toughness, resistance to chemicals and oils, hydrolysis resistance (Polyether polyurethanes), resistance to atmospheric agents and microbial (Polyether polyurethane), low coefficient friction (special polyurethane matte and silk surface: matte finish/low gloss compound), elastic memory.

It is used for spiral and extensible cables, in the automation sector, automotive, in electronics cables, for geophysical research, power supply of equipment, tools and industrial machines, signaling and command when it is required good resistance to flex for, abrasion, impact, very low temperatures and chemical and weather agents.

### **c) Conductors**

The material used is mainly bare copper or tinned copper or aluminium.

Tinned copper is recommended when welding is required in the shortest possible time.

The conductors used may be of the type:

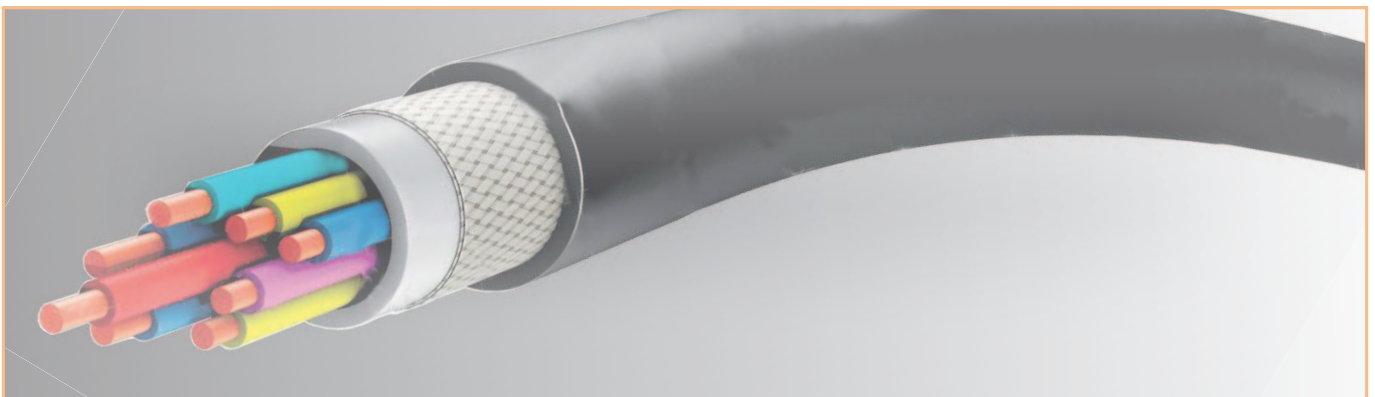
- *solid conductors*
- *bunched stranded conductors*
- *concentric stranded conductors*

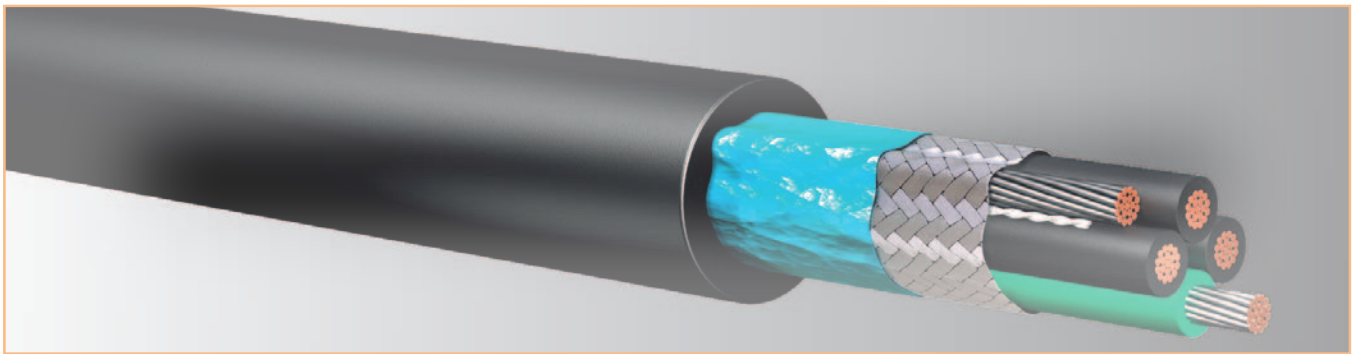
or of different flexibility depending on the application requested.

### **d) Armour**

Typical types of armour used are:

- *smooth aluminium sheath, or metal braid armour (sock)*
- *lead alloy sheath*
- *non-alloy lead sheath*
- *cylindrical reinforcement wire, normally in steel*
- *steel reinforced reinforcement*
- *steel plate reinforcement*





### e) Shielding

Typical types of shields used are:

- metallic paper or charcoal or aluminium tape screen
- strip or strip screen or copper wire
- braid or copper sleeve
- double braid or double copper braid
- longitudinal strip of corrugated steel
- coated aluminium longitudinal tape screen

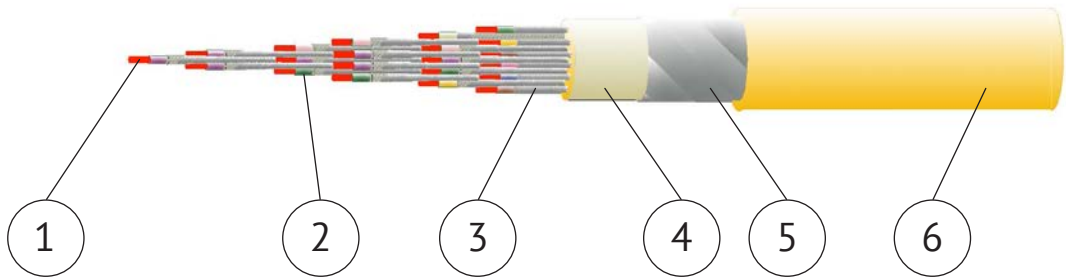
### 3.2 TYPICAL CHARACTERISTICS OF THE MATERIALS USED FOR THE INSULATION OF THE CABLES

Acronym	Material	Operating temperature °C	Density (g/cm <sup>3</sup> )	Halogen content (%)	Dielectric constant (1MHz)	Dielectric strength (kV/mm)
PVC	Polyvinylchloride	15 ÷ 90	1,25 ÷ 1,5	35	4,5	> 12
PVC (spec.)	Polyvinylchloride	-40 ÷ +125	1,25 ÷ 1,5	35	4,5	> 12
PE	Polyethylene	-50 ÷ +80	0,92 ÷ 0,96	0	2,3	> 22
XLPE	Crosslinked polyethylene	-60 ÷ +120	0,91 ÷ 0,92	0	2,3	> 22
PP	Polypropylene	+40 ÷ +105	0,9	0	2,3	> 22
TPE-O	Thermoplastic rubber	-40 ÷ +125	0,95 ÷ 0,98	0	2,7	> 20
TPE-E	Thermoplastic elastomer based on polyester	-40 ÷ +105	1,20 ÷ 1,25	0	-	> 10
TPE-U	Polyurethane	-40 ÷ +90	1,12	0	-	> 10
TPE-U (spec.)	Polyurethane	-40 ÷ +105	1,12	0	-	> 10



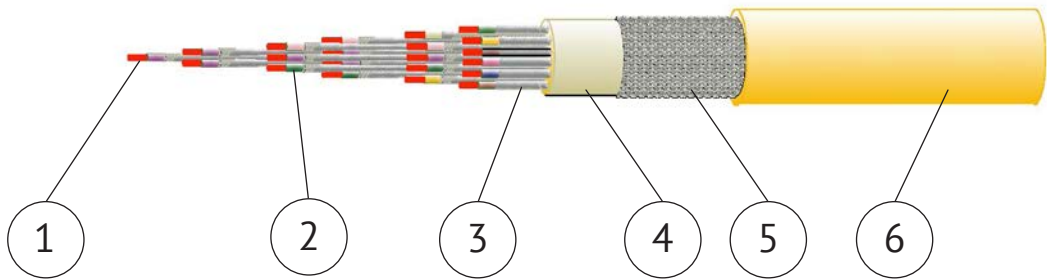
## Some examples of electro-instrument cable

### Instrumentation cables with shielding on individual core and total shielding



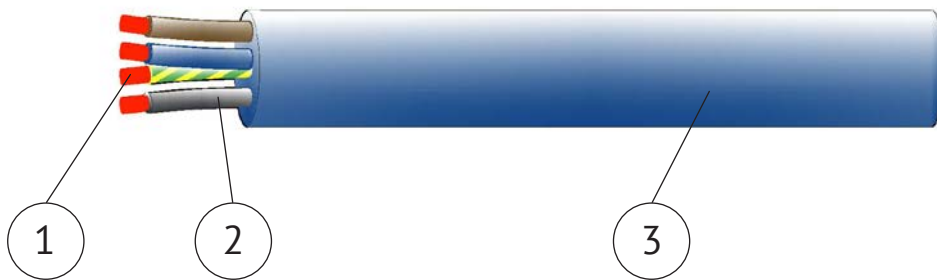
1	Conductor	Concentric copper conductor
2	Insulation	Synthetic rubber or ethylenepropylene rubber
3	Screen	Copper braid shield on individual cores
4	Filling	Non-hydrous material mixture
5	Shielding	Shielding tapes, wires or copper strips on the set of wire cores
6	Outer sheath	Common PVC, synthetic rubber or ethylenepropylene rubber

### Instrumentation cables, with shielding on the individual core and outer armour



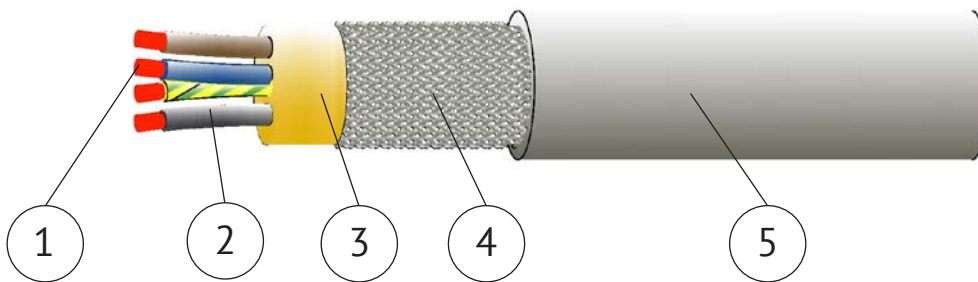
1	Conductor	Concentric copper conductor
2	Insulation	Synthetic rubber or ethylenepropylene rubber
3	Screen	Copper braid shield on individual cores
4	Filling	Non-hydrous material mixture
5	Armour	Braid armour made of steel wires or steel plates or steel strips
6	Outer sheath	Common PVC, synthetic rubber or ethylenepropylene rubber

**Common PVC, synthetic rubber or ethylenepropylene rubber**



1	Conductor	Concentric copper conductor
2	Insulation	Synthetic rubber or ethylenepropylene rubber
3	Outer sheath	Common PVC, synthetic rubber or ethylenepropylene rubber

**Instrumentation cables, with shielding on the individual core and outer armour**



1	Conductor	Concentric copper conductor
2	Insulation	Synthetic rubber or ethylenepropylene rubber
3	Filling	Non-hydrous material mixture
4	Armour	Braid armour made of steel wires or steel plates or steel strips
5	Outer sheath	Common PVC, synthetic rubber or ethylenepropylene rubber

Due to the wide variety of low and medium voltage cables and the different coding systems at international level, we provide a brief description of the coding criterion below.

Cable designation coding according to Italian standard CEI 20-27.

Reference to Standards	H	Cable conforming to harmonized standards	Conductor material	-	Copper
	A	Authorized national type cable		A	Aluminium
	N	Other type of national cable			
Rated Voltage U <sub>0</sub> /U	01	100/100V	Natura del materiale dell'isolante	V	Common PVC
	03	300/300V		V2	PVC for a temperature of 90° C
	05	300/500V		R	Synthetic rubber for a temperature of 60° C
	07	450/750V		B	Ethylenepropylene rubber
	1	0,6/1Kv		N2	Polychloroprene for welding cables
				Z	Cross-linked polyolefins with low-emission of toxic and corrosive gas and fumes
Metallic covering (shielding and armour)	C	Concentric copper conductor	Materiale della guaina	V	Common PVC
	C4	Copper braid shield on the set of cores		V2	PVC for a temperature of 90° C
	C5	Copper braid shield on individual cores		V5	PVC oil-resistant
	C7	Trips, plates or copper wires protection on the set of the cores		R	Synthetic rubber
	Z2	Round steel wire armour		B	Ethylenepropylene rubber
	Z3	Steel plates armour		N	Polychloroprene
	Z4	Steel strips armour		N8	Water-resistant polychloroprene
Cable shape	H2	Flat cables "not divisible"	Q	Polyurethane	
	H6	Flat cable with three or more cores	N4	Polyethylene chlorosulfonate or chlorinated polyethylene	
	H7	Cables with double layer insulation applied for extrusion	Z	Cross-linked polyolefins with low-emission of toxic and corrosive gas and fumes	
Conductor shape	U	Rigid single wire	Materiale della guaina	Z1	Thermoplastic polyolefins with low-emission of toxic and corrosive gas and fumes
	R	Rigid with round rope			
	F	Flexible for mobile laying			
	K	Flexible for fixing laying			
	D	Flexible for welding cables			
	E	Very flexible for welding cables			



Cable designation coding according to Italian standard UNEL 35011-2000

Nature and quality of insulation	E4	Crosslinked polyethylene compound having a characteristic temperature of 85°C	Degree of flexibility of the conductor	A	Aluminum conductor			
	G	Natural and/or synthetic rubber compound having a characteristic temperature of 60°C		F	Flexible rope conductor of round shape			
	G4	Silicone rubber compound having a characteristic temperature of 180°C		FF	Very flexible rope conductor of round shape			
	G7	High modulus ethylene-propylene rubber compound having a characteristic temperature of 90°C		R	Rigid string-shaped conductor of round shape, normally compact			
	G8	Ethylene propylene rubber compound suitable also for cables without protective covering having a characteristic temperature of 85°C		U	Single thread conductor, with round shape			
	G9	Smooth, corrosive, flame retardant elastomeric compound, suitable for cables without protective covering with a characteristic temperature of 90°C	E	Thermoplastic polyethylene based mixture	Metal covering (shield and armour)	A	Smooth aluminum sheath, or metal braid armour (sleeve)	
	G10	Crosslinked elastomeric mixture with low-development of fumes and toxic/corrosive gases having a characteristic temperature of 90°C	F	Cylindrical wires armour, normally made of steel				
	G19	Crosslinked elastomeric mixture with low-development of fumes and toxic/corrosive gases having a characteristic temperature of 90°C	H5	Coated aluminum longitudinal tape screen				
	G20	Crosslinked elastomeric mixture with low-development of fumes and toxic/corrosive gases having a characteristic temperature of 90°C	L	Coated aluminum longitudinal tape screen				
	M9	Crosslinked elastomeric mixture with low-development of fumes and toxic/corrosive gases having a characteristic temperature of 90°C	N	Steel reinforcement armour				
	R	Polyvinylchloride-based mixture having a temperature of 70° C, T11 and T12 quality	P	Non-alloy lead sheath	Concentric shields and conductors	Z	Steel plate armour	
	R2	Polyvinylchloride-based mixture having a temperature of 70° C, R2 quality	C	Copper concentric conductor				
	R4	Polyamide resin compound	H	Metallic paper or charcoal or aluminum tape protection				
	R5	Fluorocarbon resin mixture	H1	Protection with ribbons or strips or copper wires				
	R5F	Fluorocarbon-copolymer based resin mixture tetrafluoroethylene-hexafluoropropylene (FEP)	H2	Braid or copper sleeve				
	R5M	Fluorocarbon-copolymer based resin mixture tetrafluoroethylene-hexafluoropropylene	H3	Double braid or double copper sleeve	Sheaths (non-metallic covering)	H4	Longitudinal strip of corrugated steel	
	R5P	Fluorocarbon-copolymer based resin mixture tetrafluoroethylene-hexafluoropropylene	H5	Covered aluminum longitudinal tape screen				
	R7	Polyvinylchloride compound having a characteristic temperature of 90° C, T13 quality	E	Ez-quality thermoplastic sheath				
	T4	One or more strips of molten glass or closed glass braid	E4	E4M quality cross-linked polyethylene sheath				
	V	Glass impregnated canvas	G	Natural and/or Synthetic Rubber Sheath Gy quality				
T	One or more strips of molten glass or closed glass braid	G6	High quality polyethylene chlorosulfonate base compound G6M					
Cable shape	O	Cores, possibly with its own covering, combined with or without fillers, to form a round cable	K	Basic sheath of polypropylchloroprene or equivalent quality products Ky, Kn and Kz		Supporting element	R	Basic quality polyvinylchloride sheath Tm1, Tm2 and Rz
	D	Cores, possibly with its own covering, combined with or without fillers, parallel flanked to form a flattened cable	R4	Polyamide resin base sheath				
	X	Cores, possibly with its own covering, combined with or without fillers, combined in a visible helix	M1	Low-temperature thermoplastic sheath with low-development of fumes and toxic/corrosive gases				
	W	Parallel joined cores, with an intermediate groove	M2	Elastomeric sheath with low development of fumes, toxic and corrosive gases of quality M2				
	W1	Parallel joined cores with an intermediate insulating strip	M3	Elastomeric sheath with low development of fumes, toxic and corrosive gases of quality M3				
			M4	Elastomeric sheath with low development of fumes, toxic and corrosive gases of quality M4				
			T	Flexible braid (possibly impregnated) of normal type				
		T1	Glass strip bandage			S	Supporting element, generally with metal body, incorporated in the non-metallic sheath	
		T2	Flexible braid special type (possibly impregnated)			Y	Supporting element, textile or metallic, included among the cores or bounded outside the cable	

INTRODUCTION FROM CABLE GLANDS TO ELECTRICAL FITTINGS FOR ELECTRICAL PLANTS

Cable designation according to the European CEI 20-27 / CENELEC HD361 system

Reference to Standards	H	Cable conforming to harmonized standards	Metallic covering (concentric conductor and screens)	C	Concentric copper conductor	
	A	Recognized national type cable		C4	Copper protection in the form of braid on the set of cores	
	N	National type cable non-conforming to IEC Standard		C5	Copper braid shield on individual cores	
Rated Voltage U <sub>0</sub> /U	03	300/300V		C7	Strips, plates or copper wires protection	
	05	300/500V		A7	Aluminum protection	
	07	450/750V		Special shapes and constructions	Z2	Steel wires armour
	Insulating materials for sheathing	B			Ethylene propylene rubber for a continuous working temperature of 60° C	Z3
G		Ethylene-vinyl acetate			Z4	Steel strips armour
J		Glass fiber trace		Z5	Steel wire braid	
M		Mineral		Special shapes and constructions	H	"Divisible" flat cables with or without sheath
N		Polychloroprene	H2		Flat cables "not divisible"	
N2		Special polychloroprene compound for cable covering for welders	H6		Flat cable with three cores, according to HD 359 or EN 50214	
N4		Polyethylene chlorosulfonate or polyethylene chlorate	H7		Double layer insulating cable applied for extrusion	
N8		Special polychloroprene compound water-resistant	H8	Extensible rope		
Q		Polyurethane	Degree of flexibility of the conductor	D	Flexible conductor for use in cables for arc welders, according to HD 22 part 6 (different flexibility of the Class 5 of HD 383)	
Q4		Polyamide		E	Flexible conductor for use in cables for arc welders, according to HD 22 part 6 (different flexibility of the Class 5 of HD 383)	
R		Ordinary ethylenepropylene rubber and synthetic equivalent elastomer for a continuous operating temperature of 0°C.		F	Flexible conductor of a flexible cable (flexibility according to Class 5 of HB 383)	
S		Silicon rubber		H	Very flexible conductor of a flexible cable (flexibility according to Class 6 of HB 383)	
T		Textile braid, impregnated or not, on the cores as a whole		K	Flexible conductor of a cable for fixed installations (if not differently specified, flexibility according to the Class 5 of HD 383)	
T6		Textile braid, impregnated or not, on the single core of a multipolar cable		R	Sturdy, round, rope conductor	
V		Commonly used polyvinyl chloride (or PVC)		U	Sturdy, round conductor with one wire	
V2		PVC compound for a continuous operating temperature of 90°C		Y	Conductor made of similar copper	
V3		PVC compound for cables installed at low temperature				
V4		Cross-linked PVC				
V5		Special PVC compound oil resistant				
Z	Crosslinked polyolefinic compound that in case of combustion emits a low amount of fumes, toxic and corrosive gases					
Z1	Thermoplastic polyolefinic compound that in case of combustion emits a low amount of fumes, toxic and corrosive gases					

As can be understood from the identification and cable formation tables, which vary in function of the applied regulations, who designs and produces cable glands has a considerable amount of selections to do in order to be able to satisfy the needs of the designer of electro-instrumental equipment and, last but not least, a careful analysis of the dimensioning of the mechanical seals according to the diameters below armour (Inner) and max. external cable diameter (outer).

In addition to the above, the plant technician must also pay close attention to the method to be adopted for the design and choice of cable gland, always keeping in mind the requirements of IEC/EN 60079-14 para. 10.6.2 (see Figure 8 in the previous paragraph).

### 3.3 TYPICAL EXAMPLES OF PLANT DESIGN

1. *Process skids, with control panels command placed on board the machine*

In this case, since the distances of the connections are below the 3m, as required by IEC/EN 60079-14 paragraph 10.6.2. Sub b), the cable glands have to be of the barrier type.



2. *Typical plant with motor power supply and local control columns*

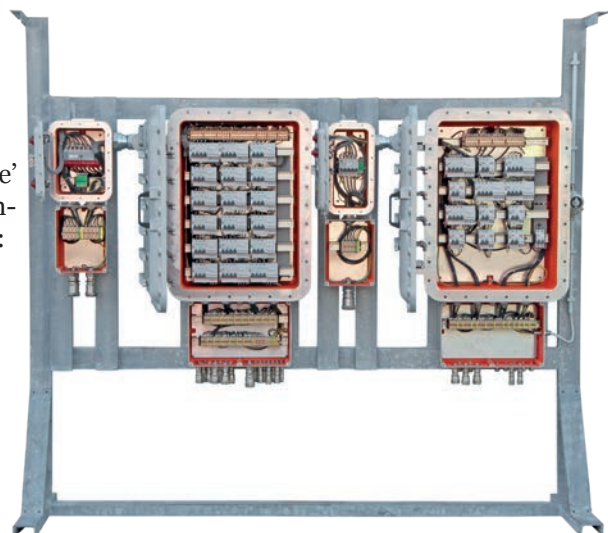


In these cases, the distances of the connections above 3m, as required by IEC/EN 60079-14 paragraph 10.6.2. Sub b), the cable glands must be of the Ex-certified type, simple or double sealing (if the cable is armoured or not armoured), respecting all the conditions of sub b), that is:

- cable glands conforming to IEC/EN 60079-1 and certified as equipment.
- cables with thermoplastic, thermosetting or elastomeric sheath, of compact circular shape, with extruded padding or sleeves and non-hygroscopic material.
- the length of the connected cable is equal to or greater than 3m, making sure that the test are in accordance with the requirements of Annex I (Limited Breathing Ventilation Test) of IEC/EN 60079-14

3. *Distribution 'Ex de' panel boards*

In these cases, as the way of protection is of "Indirect" entry through 'Ex e' box and sealed passage between 'Ex e' and 'Ex d' junction box, the concept expressed in the standard IEC/EN 60079-14, para 10.6.2 sub. C), is respected: the cable glands can be of the Ex-certified type and with simple or double sealing (if the cable is armoured or not armoured).





# 4.

## Electrical fittings, explosion proof and weather proof junction and pulling boxes

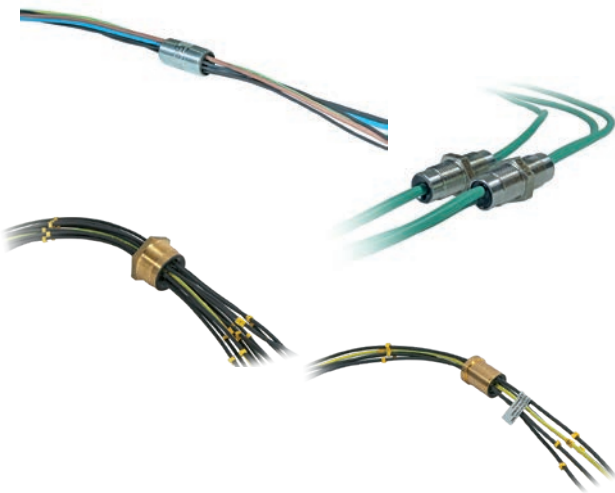
Considering the difficulty for designers to forecast the development of a plant since the first phases of its project and until the conclusion of the engineering, there are devices specifically thought to simplify the designer's job.

Elfit offers a wide range of electrical fittings which enables the realization of a complete electrical plant: three pieces unions, adaptors, closing plugs available in different threads and executions, 90° elbows, open elbows, couplings, sealing and pulling fittings, rigid and flexible conduits.



INTRODUCTION FROM CABLE GLANDS TO ELECTRICAL FITTINGS FOR ELECTRICAL PLANTS

Moreover, Elfit manufactures explosion proof and weather proof junction boxes. The ex-proof junction boxes are available in different models, size and threads and can be used for the pulling or also for the junction of conductors. Weather proof junction boxes in aluminium, stainless steel and polyester can contain electrical and electronic instruments and be installed in any industrial environment.



# 5.

## Elfit foundry: Aluminium customized die-casting items



**FIG.12 e 13**

The working process of aluminium in Elfit foundry

Elfit foundry is able to realize aluminium customized die-casting items using primary and secondary alloys in various fields: electro-mechanical, hydraulic, transports, food, lighting and furniture. The service includes the feasibility study of product, die making with filling simulation package and the production of particular customized solutions.

### ICON LEGEND

#### Certifications



Logo that identifies equipment certified for explosive areas.



ATmosphères and EXplosives. Conventional name given to the European Union Directive 2014/34/EU for the regulation of equipment intended for use in potentially explosive atmospheres.



International Electrotechnical Commission. International standards-setting organization for electricity, electronics and related technologies.



CE mark. It certifies that the product has been evaluated by the manufacturer and is believed to comply with EU safety, health and environmental protection requirements.



INMETRO certification for Brazil.

EurAsien Community certification for Eurasia.



Certification for Ukraine.

Certification for the United Arab Emirates (ECAS-Ex).



Certification for China.

Certification for India.



Certification for Great Britain.



# ELFiT®

Electrical FITtings

## Electrical connectors





FastEx electrical connectors allow to connect an equipment to the electric circuit or to others equipment safely and quickly. Available in two versions, 3 and 5 poles, their strength and extreme ease of use allow to activate the circuits quickly, fail-proof and to protect environments from risk of explosions and accidental disconnections. Their speed of implementation favours at the same time significant savings on overall installation and maintenance costs of systems. Ideal for use in indoor or outdoor environments, in chemical and petrochemical plants, of refining and other industrial processes where exists a potentially explosive atmosphere due to the presence of flammable gas, vapour or dust.



<b>Classification:</b> 2014/34/UE	Group II	Category 2GD
<b>Installation:</b> EN 60079.14	zone 1 - zone 2 (Gas)	zone 21 - zone 22 (Dust)
<b>Marking:</b>	CE 0722 Ex II 2 GD Ex eb IIC T.. Gb - Ex tb IIIC T..°C Db CE Ex II 3 GD Ex ec IIC T.. Gc - Ex tc IIIC T..°C Dc	
<b>Certification:</b>	ATEX	CML 22 ATEX 3673 X
	ATEX	CML 23 ATEX 3175 X
	IECEx	IECEx CML 22.0107X
	UKEX	AVAILABLE
<b>Standards:</b>	CENELEC EN 60079-0: 2018, EN 60079-7: 2015+A1:2018, EN 60079-31: 2014 and EUROPEAN DIRECTIVE 2014/34/EU IEC60079-0: 2017, IEC60079-7: 2017, IEC60079-31: 2013 Direttiva RoHS 2002/95/CE	
<b>Ambient temperature:</b>	-60°C +46°C (T6) -60°C +60°C (T5)	
<b>Protection rating:</b>	IP66	

Per tutti i dati di certificazione IEC Ex, UKEX scaricare il certificato dal sito [www.elfit.com](http://www.elfit.com)

I certificati sono consultabili sul sito [www.elfit.com](http://www.elfit.com)

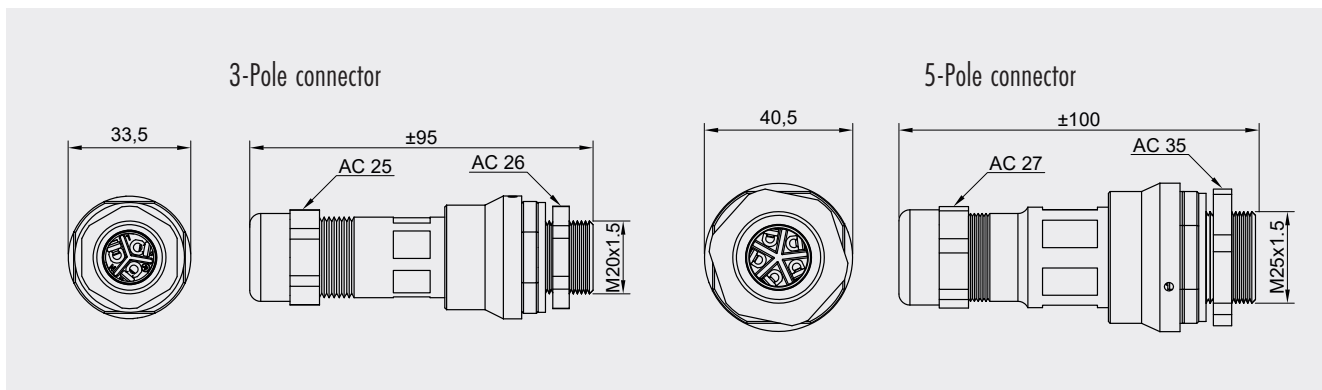
**MECHANICAL FEATURES**

- Body:**
1. Aluminum alloy with low copper content with anodizing surface treatment
  2. nickel-plated brass
  3. AISI 316L stainless steel.
- Contact holder:** Polyamide.
- Contacts:** Brass.
- Gasket:** Silicone resistant to acids and hydrocarbons.

**ELECTRICAL FEATURES**

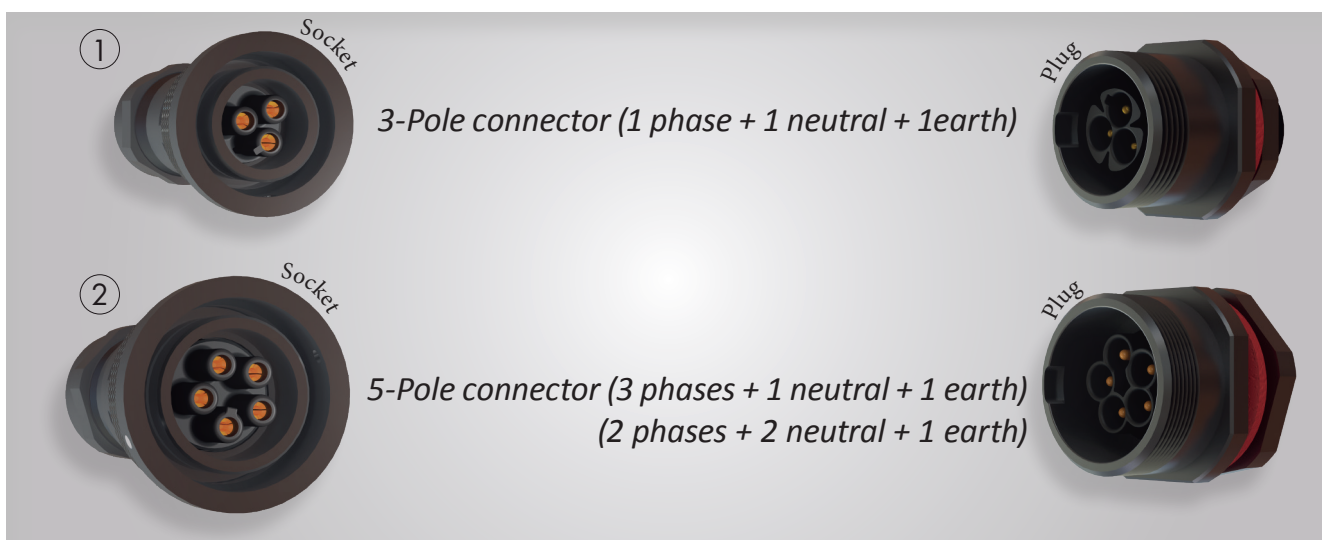
Cross section (mmq)	Max. rated current (A)	Max. voltage (Vac/dc)
0,75	10	277
1	12	277
1.5	15	277

**Rated frequency:** 0-50/60 Hz

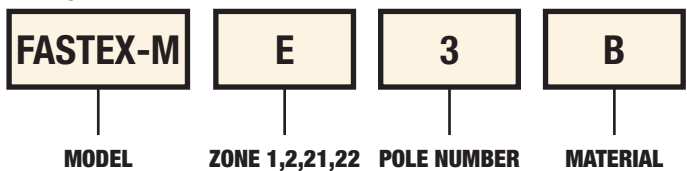


**CONNECTOR SELECTION TABLE**

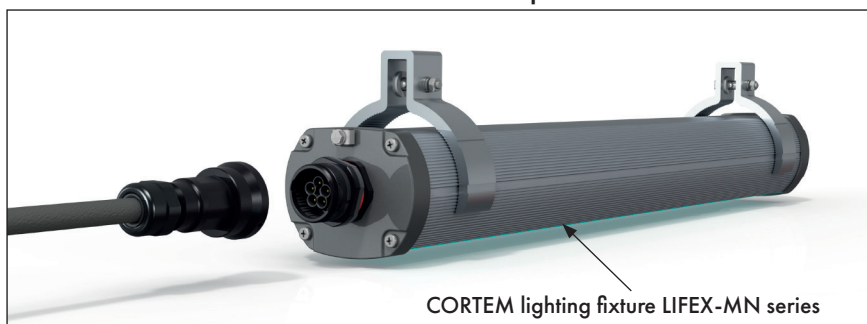
Code Aluminium	Code Nickel plated brass	Code Stainless steel	Thread	Zone	Range	Pole	Weight
					min-max Outer sheath of the cable		Kg (alluminium)
FASTEX-ME3A	FASTEX-ME3B	FASTEX-ME3SS	M20x1.5	1,2,21,22	3.5 - 8.6	3	0,087
FASTEX-ME5A	FASTEX-ME5B	FASTEX-ME5SS	M25x1.5	1,2,21,22	6.3 - 11.6	5	0,125
FASTEX-MN3A	FASTEX-MN3B	FASTEX-MN3SS	M20x1.5	2,21,22	3.5 - 8.6	3	0,087
FASTEX-MN5A	FASTEX-MN5B	FASTEX-MN5SS	M25x1.5	2,21,22	6.3 - 11.6	5	0,125



Sample order code



Installation example 2









**Cable gland series NAV for non-armoured cables from 1/4" to 4"**

NAV series cable glands are suitable for use in hazardous areas with danger of explosion to enable direct insertion of non-armoured cables into explosion-proof junction boxes, lighting fixtures, plugs and sockets, etc. Thanks to their structure, they are particularly suitable both in harsh application, such as marine one, and places subjected to stress and mechanical shock as it often happens in all those places of the "heavy" industry where safety is a top priority. They are provided with one sealing ring which tightens the incoming cable ensuring the anti-loosening and the 'Ex d' way of protection and the IP 66/68. The result is a cable gland which provides maximum performance in terms of reliability and safety over time, is compatible with a wide range of the main, commercially available cables, and complies with the most recent applicable regulations.



[NAV.. assembly instructions video](#)

<b>Classification:</b> 2014/34/EU	Group II	Category 2GD/3G
<b>Installation:</b> EN 60079.14	zone 1 - zone 2 (Gas)	zone 21 - zone 22 (Dust)
<b>Marking:</b>	CE 0722 Ex II 2 GD - Ex db IIC Gb - Ex eb IIC Gb II 2 D - Ex tb IIC Db II 3G Ex nR IIC Gc - IP66/68	
<b>Certification:</b>	ATEX (category 2):	IMQ 17 ATEX 016X
	ATEX (category 3):	IMQ 17 ATEX 017X
<b>Standards:</b>	IEC Ex	IECEX IMQ 17.0010X
	For IEC Ex and others certifications data can be downloaded at <a href="http://www.elfit.com">www.elfit.com</a>	
<b>Standards:</b>	CENELEC EN 60079-0: 2018, EN 60079-1: 2014, EN 60079-7: 2015, EN 60079-15: 2019, EN 60079-31: 2014 and EUROPEAN DIRECTIVE 2014/34/EU IEC60079-0: 2017, IEC60079-1: 2014, IEC60079-7: 2017, IEC60079-15: 2017, IEC60079-31: 2013 RoHS Directive 2002/95/EC	
<b>Operating temperature:</b>	-60 °C +130 °C	
<b>Protection rating:</b>	IP66/68 (30 meters - 12 hours)	
<b>Design</b>	BS 6121: Part 1:1989, IEC 62444, EN 62444	

Certificates are available on [www.elfit.com](http://www.elfit.com)

**ACCESSORIES UPON REQUEST**

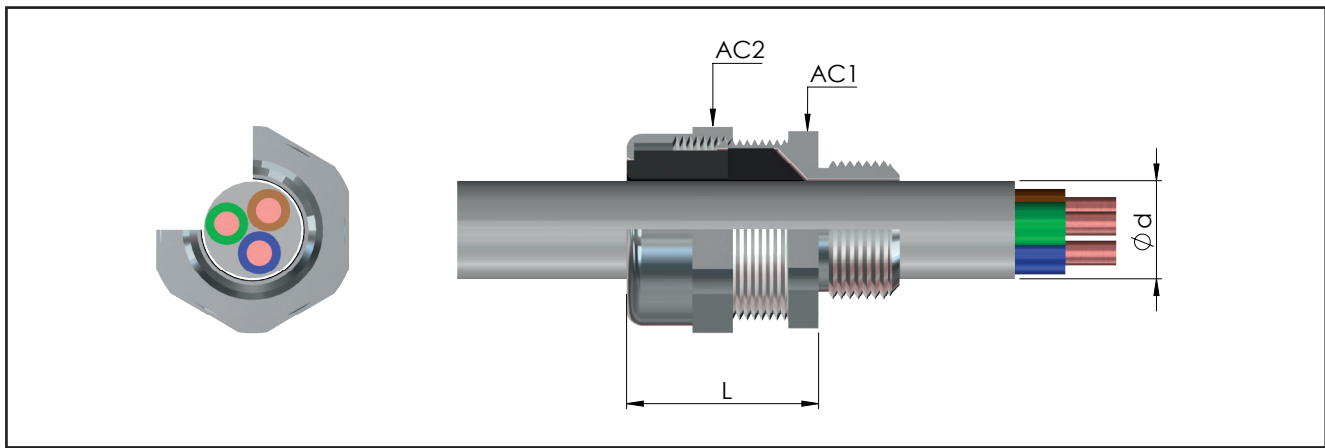
Locknuts	ISO thread	Nickel-plated brass	Galvanized steel	Stainless steel
	M12x1,5	DL02IB	DL02IG	DL02IS
	M16x1,5	DL01IB	DL01IG	DL01IS
	M20x1,5	DL11IB	DL11IG	DL11IS
	M25x1,5	DL21IB	DL21IG	DL21IS
	M32x1,5	DL31IB	DL31IG	DL31IS
	M40x1,5	DL41IB	DL41IG	DL41IS
	M50x1,5	DL51IB	DL51IG	DL51IS
	M63x1,5	DL61IB	DL61IG	DL61IS
	M75x1,5	DL71IB	DL71IG	DL71IS
	M90x1,5	DL81IB	DL81IG	DL81IS
	M100x1,5	DL101IB	DL101IG	DL101IS
	M115x1,5	DL115IB	DL115IG	DL115IS

Nickel-plated brass earthing rings	ISO thread	Nickel-plated brass	Stainless steel	Serrated stainless steel lock washers	Code	Adapters and reducers of the RE... series
	M12x1,5	A0231IB	A0231IS		RD102IS/A4	
	M16x1,5	A0131IB	A0131IS		RD101IS/A4	
	M20x1,5	A131IB	A131IS		RD11IS/A4	
	M25x1,5	A231IB	A231IS		RD12IS/A4	
	M32x1,5	A331IB	A331IS		RD13IS/A4	
	M40x1,5	A431IB	A431IS		RD14IS/A4	
	M50x1,5	A531IB	A531IS		RD15IS/A4	
	M63x1,5	A631IB	A631IS		RD16IS/A4	
	M75x1,5	A731IB	A731IS			
	M90x1,5	A831IB	A831IS			
	M100x1,5	A1031IB	A1031IS			
	M115x1,5	A1031IB	A1031IS			

Black TPV protector	Cableglands	Code	
	NAV01NB	NAV16IB	PGA1F
	NAV1SNB	NAV20SIB	PGA1N
	NAV1NB	NAV20IB	PGA1
	NAV2NB	NAV25IB	PGA2N
	NAV3NB	NAV32IB	PGA4
	NAV4NB	NAV40IB	PGA4
	NAV5SNB	NAV50SIB	PGA5
	NAV5NB	NAV50IB	PGA5N
	NAV6SNB	NAV63SIB	PGA6
	NAV6NB	NAV63IB	PGA6
NAV7SNB	NAV75SIB	PGA7	
NAV7NB	NAV75IB	GTR7 Heat shrinkable	
NAV8NB	NAV90IB		
NAV9NB	NAV100IB		
NAV10NB	NAV115IB		

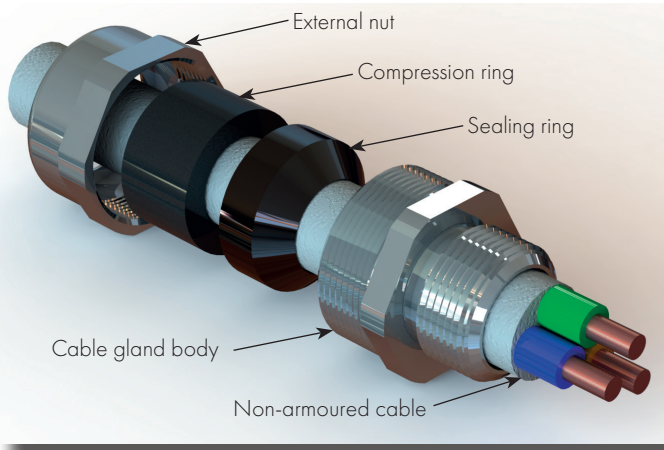
\* For different threads, contact the sales department.



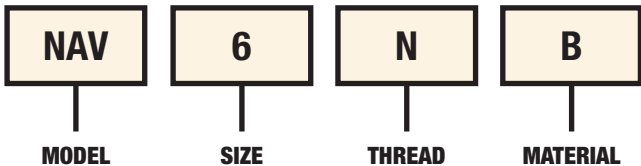


CABLE GLAND SELECTION TABLE								
Code Nickel-plated brass	Thread	Code Nickel-plated brass	Thread	Dimensions in mm			Range	Weight Kg
				AC1	AC2	L	Ød min-max Outer sheath of the cable	
NAV02NB	1/4" NPT	NAV12IB	M12x1,5	18	18	34	3.0 - 6.0	0,060
NAV01NB	3/8" NPT	NAV16IB	M16x1,5	24	24	34	3.5 - 8.6	0,086
NAV1SNB	1/2" NPT	NAV20SIB	M20x1,5	24	26	34	6.3 - 11.6	0,093
NAV1NB	1/2" NPT	NAV20IB	M20x1,5	30	32	37	6.5 - 14	0,126
NAV2NB	3/4" NPT	NAV25IB	M25x1,5	36	38	37	11 - 20	0,153
NAV3NB	1" NPT	NAV32IB	M32x1,5	45	47	40	17 - 27	0,232
NAV4NB	1 1/4" NPT	NAV40IB	M40x1,5	50	52	40	22 - 32	0,295
NAV5SNB	1 1/2" NPT	NAV50SIB	M50x1,5	55	57	43	29.5 - 38	0,374
NAV5NB	2" NPT	NAV50IB	M50x1,5	62/60*	62	43	35.5 - 44	0,329
NAV6SNB	2" NPT	NAV63SIB	M63x1,5	68	77	51	40 - 50	0,753
NAV6NB	2 1/2" NPT	NAV63IB	M63x1,5	75/73*	77	52	47 - 56	0,732
NAV7SNB	2 1/2" NPT	NAV75SIB	M75x1,5	80	82	55	53 - 62	0,714
NAV7NB	3" NPT	NAV75IB	M75x1,5	90/85*	90	56	59 - 68	0,627
NAV8NB	3" NPT	NAV90IB	M90x1,5	100	110	59	66 - 79	1,384
NAV9NB	3 1/2" NPT	NAV100IB	M100x1,5	115	120	62	76 - 91	1,316
NAV10NB	4" NPT	NAV115IB	M115x1,5	120	130	62	86 - 98	1,937

\* Dimensions with threaded: NPT / ISO



Sample order code



TECHNICAL NOTES:

- Silicone o-rings are supplied for cylindrical threads (ISO metric) for the pre-assembled IP seal on the cable gland
- The ISO7/1 thread version is available upon request (sample code NAV1B)
- Also available in stainless steel AISI 316 (sample code NAV1S)
- Other materials on request
- For "Ex i" intrinsic safety version, RAL 5015 blue nut (sample code NAV1IA)

**Cable glands series NAVF for non-armoured cable with female entry**

NAVF series cable glands, with a female threaded outlet fitting, are suitable for use in areas with the risk of explosion, allowing the direct insertion of non-armoured cables in explosion proof enclosures, light fixtures, outlets, plugs, etc. Their structure makes them suitable for environments which are particularly difficult, such as marine environments, or where there are subjected to the mechanical stresses and impacts which often occur in heavy industry, where safety is the utmost priority. They are supplied with a sealing ring which is stretched over the cable at the inlet ensuring the anti-loosening, the 'Ex d' execution and an IP66/68 protection rating. The result is a cable gland which provides maximum performance, long-term reliability and safety, is compatible with a wide range of the main, commercially available cables, and complies with the most recent applicable regulations.



[NAVF.. assembly instructions video](#)

<b>Classification:</b> 2014/34/EU	Group II	Category 2GD/3G
<b>Installation:</b> EN 60079.14	zone 1 - zone 2 (Gas)	zone 21 - zone 22 (Dust)
<b>Marking:</b>	CE 0722 Ex II 2 GD - Ex db IIC Gb - Ex eb IIC Gb II 2 D - Ex tb IIC Db II 3G Ex nR IIC Gc - IP66/68	
<b>Certification:</b>	ATEX (category 2):	IMQ 17 ATEX 016X
	ATEX (category 3):	IMQ 17 ATEX 017X
<b>Standards:</b>	IEC Ex	IECEX IMQ 17.0010X
	For IEC Ex and others certifications data can be downloaded at <a href="http://www.elfit.com">www.elfit.com</a>	
<b>Operating temperature:</b>	-60 °C +130 °C	
<b>Protection rating:</b>	IP66/68 (30 meters - 12 hours)	
<b>Design</b>	BS 6121: Part 1:1989, IEC 62444, EN 62444	

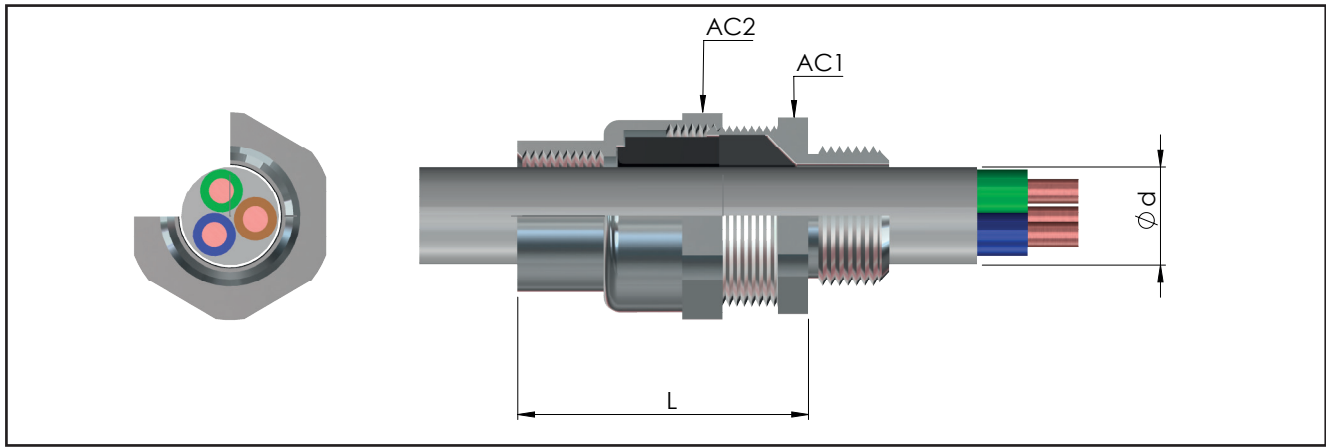
Certificates are available on [www.elfit.com](http://www.elfit.com)

ACCESSORIES UPON REQUEST					
Locknuts	ISO thread	Nickel-plated brass	Galvanized steel	Stainless steel	Sealing ring for flat/healing cables
	M12x1,5	DL02IB	DL02IG	DL02IS	
	M16x1,5	DL01IB	DL01IG	DL01IS	
	M20x1,5	DL1IB	DL1IG	DL1IS	
	M25x1,5	DL2IB	DL2IG	DL2IS	
	M32x1,5	DL3IB	DL3IG	DL3IS	
	M40x1,5	DL4IB	DL4IG	DL4IS	
	M50x1,5	DL5IB	DL5IG	DL5IS	
	M63x1,5	DL6IB	DL6IG	DL6IS	
	M75x1,5	DL7IB	DL7IG	DL7IS	
	M90x1,5	DL8IB	DL8IG	DL8IS	
	M100x1,5	DL10IB	DL10IG	DL10IS	
M115x1,5	DL115IB	DL115IG	DL115IS		

Code and dimensions are in the page p. B.16

Nickel-plated brass earthing rings	ISO thread	Nickel-plated brass	Stainless steel	Serrated stainless steel lock washers	Code	Adapters and reducers of the RE... series
	M12x1,5	A0231IB	A0231IS		RD101S/A4 RD11S/A4 RD12S/A4 RD13S/A4 RD14S/A4 RD15S/A4 RD16S/A4	
	M16x1,5	A0131IB	A0131IS			
	M20x1,5	A131IB	A131IS			
	M25x1,5	A231IB	A231IS			
	M32x1,5	A331IB	A331IS			
	M40x1,5	A431IB	A431IS			
	M50x1,5	A531IB	A531IS			
	M63x1,5	A631IB	A631IS			
	M75x1,5	A731IB	A731IS			
	M90x1,5	A831IB	A831IS			
	M100x1,5	A1031IB	A1031IS			
M115x1,5	A1031B	A1031S				

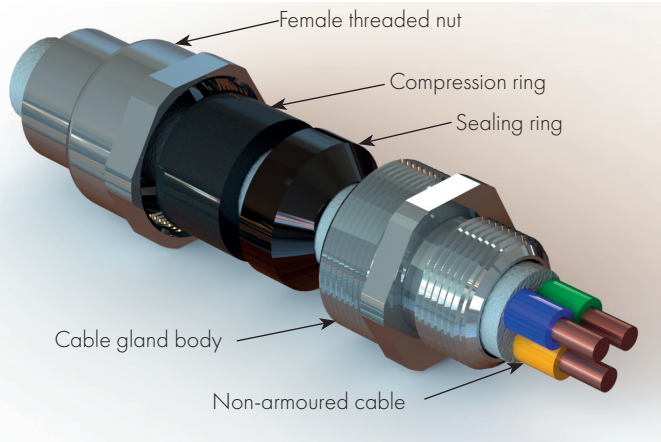
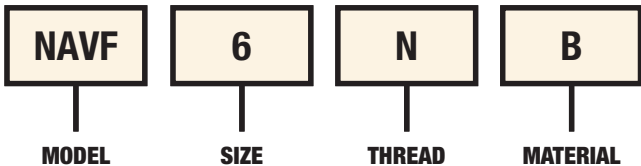
\* For different threads, contact the sales department.



CABLE GLAND SELECTION TABLE								
Code Nickel-plated brass	Thread	Code Nickel-plated brass	Thread	Dimensions in mm			Range	Weight
				AC1	AC2	L	Ød min-max Outer sheath of the cable	Kg
NAVF02NB	1/4" NPT	NAVF12IB	M12x1,5	18	18	54	3.0 - 6.0	0,070
NAVF01NB	3/8" NPT	NAVF16IB	M16x1,5	24	24	53	3.5 - 8.6	0,107
NAVF1SNB	1/2" NPT	NAVF20SIB	M20x1,5	24	26	53	6.3 - 11.6	0,120
NAVF1NB	1/2" NPT	NAVF20IB	M20x1,5	30	32	56	6.5 - 14	0,155
NAVF2NB	3/4" NPT	NAVF25IB	M25x1,5	36	38	56	11 - 20	0,212
NAVF3NB	1" NPT	NAVF32IB	M32x1,5	45	47	59	17 - 27	0,276
NAVF4NB	1 1/4" NPT	NAVF40IB	M40x1,5	50	52	59	22 - 32	0,365
NAVF5SNB	1 1/2" NPT	NAVF50SIB	M50x1,5	55	57	63	29.5 - 38	0,482
NAVF5NB	2" NPT	NAVF50IB	M50x1,5	62/60*	62	63	35.5 - 44	0,428
NAVF6SNB	2" NPT	NAVF63SIB	M63x1,5	68	77	74	40 - 50	0,981
NAVF6NB	2 1/2" NPT	NAVF63IB	M63x1,5	75/73*	77	75	47 - 56	0,741
NAVF7SNB	2 1/2" NPT	NAVF75SIB	M75x1,5	80	82	77	53 - 62	0,835
NAVF7NB	3" NPT	NAVF75IB	M75x1,5	90/85*	90	78	59 - 68	0,934
NAVF8NB	3" NPT	NAVF90IB	M90x1,5	100	110	88	66 - 79	1,883
NAVF9NB	3 1/2" NPT	NAVF100IB	M100x1,5	115	120	92	76 - 91	1,993
NAVF10NB	4" NPT	NAVF115IB	M115x1,5	120	130	92	86 - 98	2,332

\* Dimensions with threaded: NPT / ISO

**Sample order code**



**TECHNICAL NOTES:**

- Silicone o-rings are supplied for cylindrical threads (ISO metric) for the pre-assembled IP seal on the cable gland
- The ISO7/1 thread version is available upon request (sample code NAVF1B)
- Also available in stainless steel AISI 316 (sample code NAVF1S)
- Other materials on request
- For "Ex i" intrinsic safety version, RAL 5015 blue nut (sample code NAVF1IA)

## Cable glands series NAVN for non-armoured cable with male entry

NAVN series cable glands, with a male outlet fitting, are suitable for use in areas with the risk of explosion, allowing the direct insertion of non-armoured cables in explosion proof enclosures, light fixtures, outlets, plugs, etc. Their structure makes them suitable for environments which are particularly difficult, such as marine environments, or where there are subjected to the mechanical stresses and impacts which often occur in heavy industry, where safety is the utmost priority. They are supplied with a sealing ring which is stretched over the cable at the inlet, ensuring the anti-loosening, 'Ex d' execution and an IP66/68 protection rating. The result is a cable gland which provides maximum performance, long-term reliability and safety, is compatible with a wide range of the main, commercially available cables, and complies with the most recent applicable regulations.



[NAV assembly instructions video](#)

<b>Classification:</b> 2014/34/EU	Group II	Category 2GD/3G
<b>Installation:</b> EN 60079.14	zone 1 - zone 2 (Gas)	zone 21 - zone 22 (Dust)
<b>Marking:</b>	CE 0722 Ex II 2 GD - Ex db IIC Gb - Ex eb IIC Gb II 2 D - Ex tb IIC Db II 3G Ex nR IIC Gc - IP66/68	
<b>Certification:</b>	ATEX (category 2):	IMQ 17 ATEX 016X
	ATEX (category 3):	IMQ 17 ATEX 017X
	IEC Ex	IECEX IMQ 17.0010X <small>For IEC Ex and others certifications data can be downloaded at <a href="http://www.elfit.com">www.elfit.com</a></small>
<b>Standards:</b>	CENELEC EN 60079-0: 2018, EN 60079-1: 2014, EN 60079-7: 2015, EN 60079-15: 2019, EN 60079-31: 2014 and EUROPEAN DIRECTIVE 2014/34/EU IEC60079-0: 2017, IEC60079-1: 2014, IEC60079-7: 2017, IEC60079-15: 2017, IEC60079-31: 2013 RoHS Directive 2002/95/EC	
<b>Operating temperature:</b>	-60 °C +130 °C	
<b>Protection rating:</b>	IP66/68 (30 meters - 12 hours)	
<b>Design</b>	BS 6121: Part 1:1989, IEC 62444, EN 62444	

Certificates are available on [www.elfit.com](http://www.elfit.com)

### ACCESSORIES UPON REQUEST

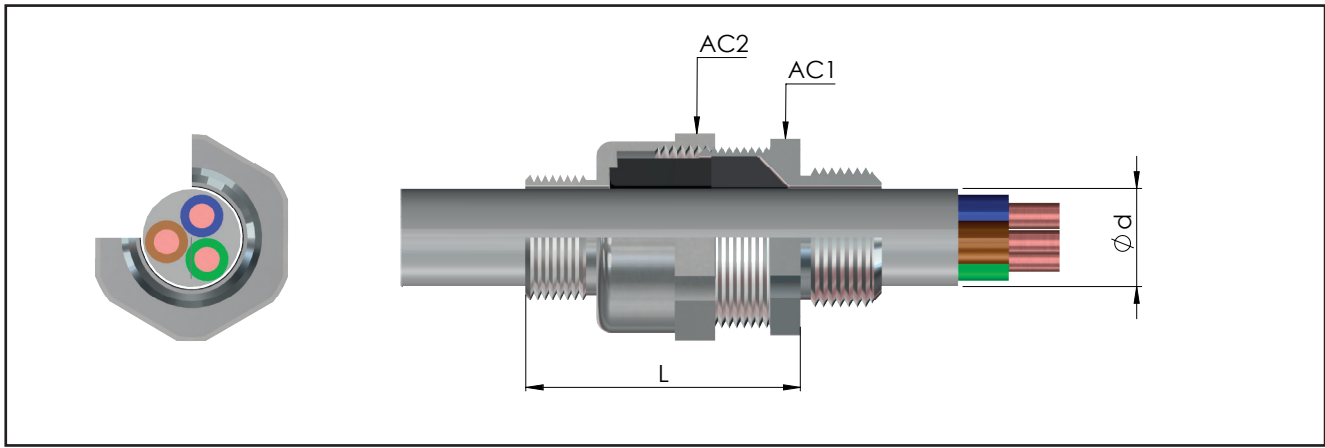
Locknuts	ISO thread	Nickel-plated brass	Galvanized steel	Stainless steel	Sealing ring for flat/healing cables
	M12x1,5	DL02IB	DL02IG	DL02IS	
	M16x1,5	DL01IB	DL01IG	DL01IS	
	M20x1,5	DL1IB	DL1IG	DL1IS	
	M25x1,5	DL2IB	DL2IG	DL2IS	
	M32x1,5	DL3IB	DL3IG	DL3IS	
	M40x1,5	DL4IB	DL4IG	DL4IS	
	M50x1,5	DL5IB	DL5IG	DL5IS	
	M63x1,5	DL6IB	DL6IG	DL6IS	
	M75x1,5	DL7IB	DL7IG	DL7IS	
	M90x1,5	DL8IB	DL8IG	DL8IS	
	M100x1,5	DL10IB	DL10IG	DL10IS	
	M115x1,5	DL115IB	DL115IG	DL115IS	

Code and dimensions are in the page p. B.16

Nickel-plated brass earthing rings	ISO thread	Nickel-plated brass	Stainless steel	Serrated stainless steel lock washers	Code	Adapters and reducers of the RE... series
	M12x1,5	A0231IB	A0231IS		RD101S/A4 RD11S/A4 RD12S/A4 RD13S/A4 RD14S/A4 RD15S/A4 RD16S/A4	
	M16x1,5	A0131IB	A0131IS			
	M20x1,5	A131IB	A131IS			
	M25x1,5	A231IB	A231IS			
	M32x1,5	A331IB	A331IS			
	M40x1,5	A431IB	A431IS			
	M50x1,5	A531IB	A531IS			
	M63x1,5	A631IB	A631IS			
	M75x1,5	A731IB	A731IS			
	M90x1,5	A831IB	A831IS			
	M100x1,5	A1031IB	A1031IS			
	M115x1,5	A1031B	A1031S			

\* For different threads, contact the sales department.



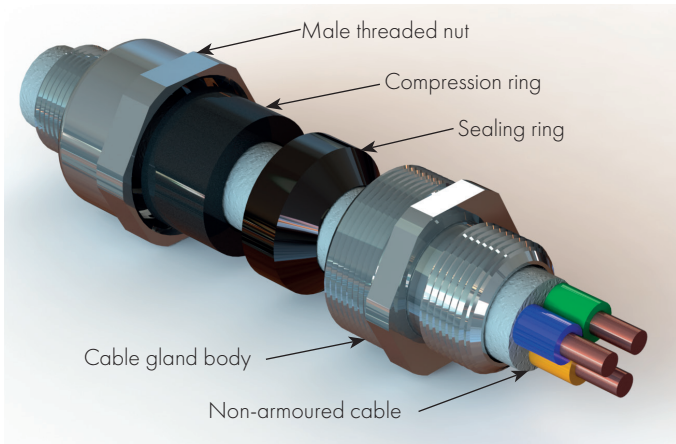
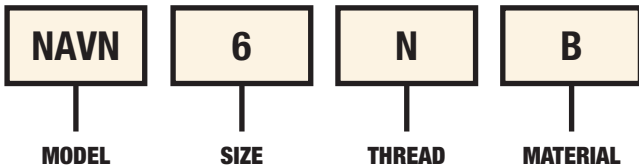


**CABLE GLAND SELECTION TABLE**

Code Nickel-plated brass	Thread	Code Nickel-plated brass	Thread	Dimensions in mm			Range Ød min-max Outer sheath of the cable	Weight Kg
				AC1	AC2	L		
NAVN02NB	1/4" NPT	NAVN12IB	M12x1,5	18	18	52	3.0 - 6.0	0,110
NAVN01NB	3/8" NPT	NAVN16IB	M16x1,5	24	24	53	3.5 - 8.6	0,150
NAVN1SNB	1/2" NPT	NAVN20SIB	M20x1,5	24	26	53	6.3 - 11.6	0,172
NAVN1NB	1/2" NPT	NAVN20IB	M20x1,5	30	32	56	6.5 - 14	0,233
NAVN2NB	3/4" NPT	NAVN25IB	M25x1,5	36	38	56	11 - 20	0,303
NAVN3NB	1" NPT	NAVN32IB	M32x1,5	45	47	59	17 - 27	0,436
NAVN4NB	1 1/4" NPT	NAVN40IB	M40x1,5	50	52	59	22 - 32	0,566
NAVN5SNB	1 1/2" NPT	NAVN50SIB	M50x1,5	55	57	63	29.5 - 38	0,748
NAVN5NB	2" NPT	NAVN50IB	M50x1,5	62/60*	62	63	35.5 - 44	0,673
NAVN6SNB	2" NPT	NAVN63SIB	M63x1,5	68	77	74	40 - 50	1,361
NAVN6NB	2 1/2" NPT	NAVN63IB	M63x1,5	75/73*	77	75	47 - 56	0,748
NAVN7SNB	2 1/2" NPT	NAVN75SIB	M75x1,5	80	82	77	53 - 62	1,479
NAVN7NB	3" NPT	NAVN75IB	M75x1,5	90/85*	90	78	59 - 68	1,235
NAVN8NB	3" NPT	NAVN90IB	M90x1,5	100	110	88	66 - 79	2,466
NAVN9NB	3 1/2" NPT	NAVN100IB	M100x1,5	115	120	92	76 - 91	2,687
NAVN10NB	4" NPT	NAVN115IB	M115x1,5	120	130	92	86 - 98	3,702

\* Dimensions with threaded: NPT / ISO

**Sample order code**

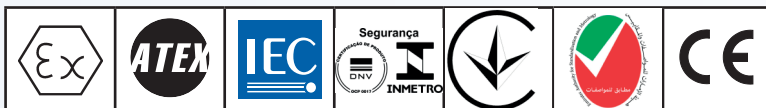


**TECHNICAL NOTES:**

- Silicone o-rings are supplied for cylindrical threads (ISO metric) for the pre-assembled IP seal on the cable gland
- The ISO7/1 thread version is available upon request (sample code NAVN1B)
- Also available in stainless steel AISI 316 (sample code NAVN1S)
- Other materials on request
- For "Ex i" intrinsic safety version, RAL 5015 blue nut (sample code NAVN1IA)

**Cable glands series NAVFS for non-armoured cable with "swivel" female**

NAVFS series cable glands, with a female threaded outlet fitting, are suitable for use in areas with the risk of explosion, allowing the direct insertion of non-armoured cables in explosion proof enclosures, light fixtures, outlets, plugs, etc. The built-in swivel joint allows an easy and quick closure of the thread between the pipe or the hose and the cable gland and, therefore, a simple installation of the assembly. They are supplied with a sealing ring which is stretched over the cable at the inlet, ensuring 'Ex d' execution and an IP66/68 protection rating. The result is a cable gland which provides maximum performance, long-term reliability and safety, is compatible with a wide range of the main, commercially available cables, and complies with the most recent applicable regulations.



[NAV assembly instructions video](#)

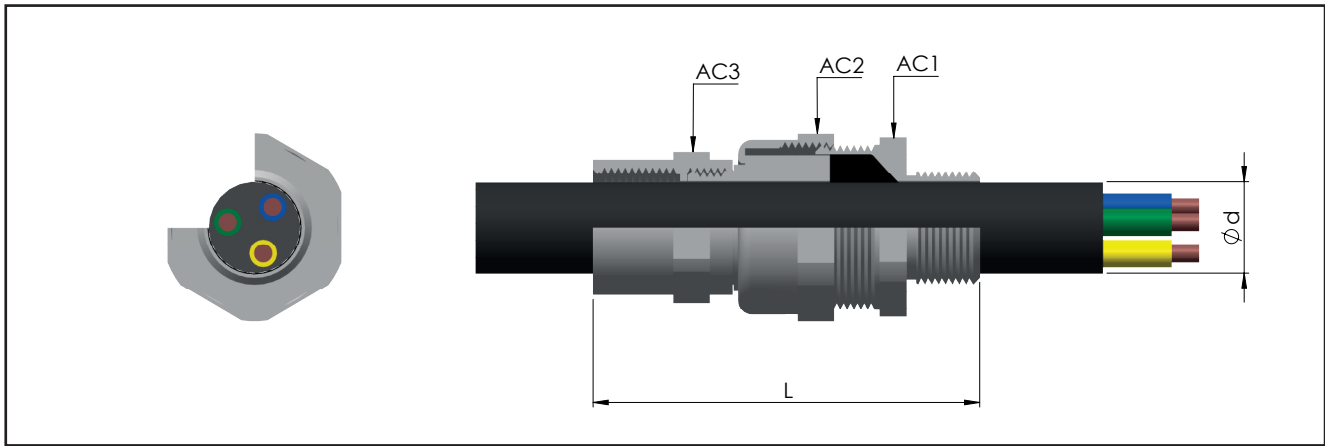
<b>Classification:</b> 2014/34/EU	Group II	Category 2GD/3G
<b>Installation:</b> EN 60079.14	zone 1 - zone 2 (Gas)	zone 21 - zone 22 (Dust)
<b>Marking:</b>	CE 0722 Ex II 2 GD - Ex db IIC Gb - Ex eb IIC Gb II 2 D - Ex tb IIIC Db II 3G Ex nR IIC Gc - IP66/68	
<b>Certification:</b>	ATEX (category 2):	IMQ 17 ATEX 016X
	ATEX (category 3):	IMQ 17 ATEX 017X
<b>Standards:</b>	IEC Ex	IECEX IMQ 17.0010X
	For IEC Ex and others certifications data can be downloaded at <a href="http://www.elfit.com">www.elfit.com</a>	
<b>Standards:</b>	CENELEC EN 60079-0: 2018, EN 60079-1: 2014, EN 60079-7: 2015, EN 60079-15: 2019, EN 60079-31: 2014 and EUROPEAN DIRECTIVE 2014/34/EU IEC60079-0: 2017, IEC60079-1: 2014, IEC60079-7: 2017, IEC60079-15: 2017, IEC60079-31: 2013 RoHS Directive 2002/95/EC	
<b>Operating temperature:</b>	-60 °C +130 °C	
<b>Protection rating:</b>	IP66/68 (30 meters - 12 hours)	
<b>Design</b>	BS 6121: Part 1:1989, IEC 62444, EN 62444	

Certificates are available on [www.elfit.com](http://www.elfit.com)

ACCESSORIES UPON REQUEST				
Locknuts	ISO thread	Nickel-plated brass	Galvanized steel	Stainless steel
	M12x1,5	DL02IB	DL02IG	DL02IS
	M16x1,5	DL01IB	DL01IG	DL01IS
	M20x1,5	DL1IB	DL1IG	DL1IS
	M25x1,5	DL2IB	DL2IG	DL2IS
	M32x1,5	DL3IB	DL3IG	DL3IS
	M40x1,5	DL4IB	DL4IG	DL4IS
	M50x1,5	DL5IB	DL5IG	DL5IS
	M63x1,5	DL6IB	DL6IG	DL6IS
	M75x1,5	DL7IB	DL7IG	DL7IS
	M90x1,5	DL8IB	DL8IG	DL8IS
	M100x1,5	DL10IB	DL10IG	DL10IS
	M115x1,5	DL115IB	DL115IG	DL115IS

Nickel-plated brass earthing rings	ISO thread	Nickel-plated brass	Stainless steel	Serrated stainless steel lock washers	Code	Adapters and reducers of the RE... series
	M12x1,5	A0231IB	A0231IS		RD101S/A4 RD11S/A4 RD12IS/A4 RD13IS/A4 RD14IS/A4 RD15IS/A4 RD16IS/A4	
	M16x1,5	A0131IB	A0131IS			
	M20x1,5	A131IB	A131IS			
	M25x1,5	A231IB	A231IS			
	M32x1,5	A331IB	A331IS			
	M40x1,5	A431IB	A431IS			
	M50x1,5	A531IB	A531IS			
	M63x1,5	A631IB	A631IS			
	M75x1,5	A731IB	A731IS			
	M90x1,5	A831IB	A831IS			
	M100x1,5	A1031IB	A1031IS			
	M115x1,5	A1031B	A1031S			

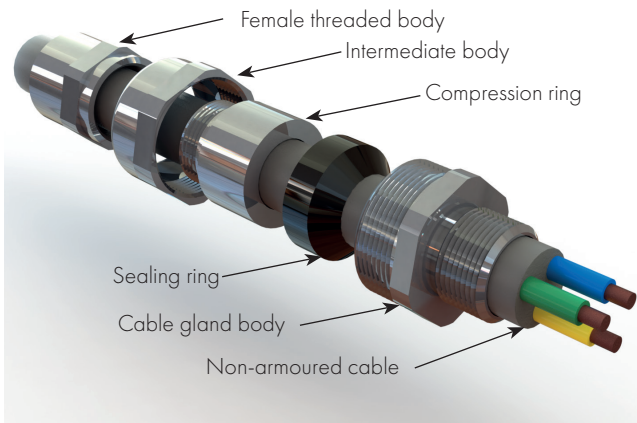
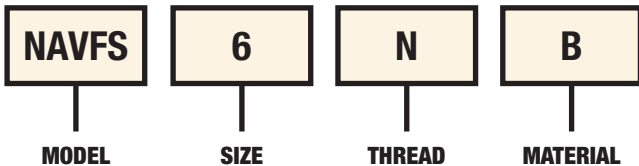
\* For different threads, contact the sales department.



CABLE GLAND SELECTION TABLE									
Code Nickel-plated brass	Thread	Code Nickel-plated brass	Thread	Dimensions in mm				Range	Weight
				AC1	AC2	AC3	L	Ød min-max Outer sheath of the cable	Kg
NAVFS02NB	1/4" NPT	NAVFS12IB	M12x1,5	18	18	20	63.5	3.0 - 6.0	0,120
NAVFS01NB	3/8" NPT	NAVFS16IB	M16x1,5	24	24	24	65.5	3.5 - 8.6	0,171
NAVFS1SNB	1/2" NPT	NAVFS20SIB	M20x1,5	24	26	24	65.5	6.3 - 11.6	0,186
NAVFS1NB	1/2" NPT	NAVFS20IB	M20x1,5	30	32	24	68.5	6.5 - 14	0,239
NAVFS2NB	3/4" NPT	NAVFS25IB	M25x1,5	36	38	30	68.5	11 - 20	0,314
NAVFS3NB	1" NPT	NAVFS32IB	M32x1,5	45	47	38	71.5	17 - 27	0,450
NAVFS4NB	1 1/4" NPT	NAVFS40IB	M40x1,5	50	52	47	71.5	22 - 32	0,605
NAVFS5SNB	1 1/2" NPT	NAVFS50SIB	M50x1,5	55	57	57	74.5	29.5 - 38	0,795
NAVFS5NB	2" NPT	NAVFS50IB	M50x1,5	60	62	57	76.5	35.5 - 44	0,723
NAVFS6SNB	2" NPT	NAVFS63SIB	M63x1,5	68	77	70	87.5	40 - 50	1,447
NAVFS6NB	2 1/2" NPT	NAVFS63IB	M63x1,5	73	77	73	88	47 - 56	1,368
NAVFS7SNB	2 1/2" NPT	NAVFS75SIB	M75x1,5	80	82	82	91	53 - 62	1,512
NAVFS7NB	3" NPT	NAVFS75IB	M75x1,5	85	90	82	92	59 - 68	1,327
NAVFS8NB	3" NPT	NAVFS90IB	M90x1,5	100	110	100	101	66 - 79	2,356
NAVFS9NB	3 1/2" NPT	NAVFS100IB	M100x1,5	115	120	110	105.5	76 - 91	3,008
NAVFS10NB	4" NPT	NAVFS115IB	M115x1,5	120	130	130	105.5	86 - 98	3,704

\* Dimensions with threaded: NPT / ISO

**Sample order code**

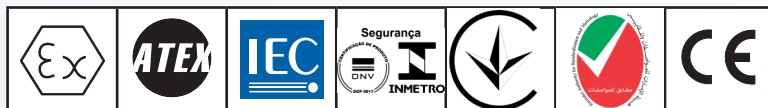


**TECHNICAL NOTES:**

- Silicone o-rings are supplied for cylindrical threads (ISO metric) for the pre-assembled IP seal on the cable gland
- The ISO7/1 thread version is available upon request (sample code NAVFS1B)
- Also available in stainless steel AISI 316 (sample code NAVFS1S)
- Other materials on request
- For "Ex i" intrinsic safety version, RAL 5015 blue nut (sample code NAVFS1IA)

**Cable glands series NAVNS for non-armoured cable with "swivel" male**

NAVNS series cable glands, with a male threaded outlet fitting, are suitable for use in areas with the risk of explosion, allowing the direct insertion of non-armoured cables in explosion proof enclosures, light fixtures, outlets, plugs, etc. The built-in swivel joint allows an easy and quick closure of the thread between the pipe or the hose and the cable gland and, therefore, a simple installation of the assembly. They are supplied with a sealing ring which is stretched over the cable at the inlet, ensuring 'Ex d' execution and an IP66/68 protection rating. The result is a cable gland which provides maximum performance, long-term reliability and safety, is compatible with a wide range of the main, commercially available cables, and complies with the most recent applicable regulations.



[NAV assembly instructions video](#)

<b>Classification:</b> 2014/34/EU	Group II	Category 2GD/3G
<b>Installation:</b> EN 60079.14	zone 1 - zone 2 (Gas)	zone 21 - zone 22 (Dust)
<b>Marking:</b>	CE 0722 Ex II 2 GD - Ex db IIC Gb - Ex eb IIC Gb II 2 D - Ex tb IIIC Db II 3G Ex nR IIC Gc - IP66/68	
<b>Certification:</b>	ATEX (category 2):	IMQ 17 ATEX 016X
	ATEX (category 3):	IMQ 17 ATEX 017X
<b>Standards:</b>	IEC Ex	IECEX IMQ 17.0010X
	For IEC Ex and others certifications data can be downloaded at <a href="http://www.elfit.com">www.elfit.com</a>	
<b>Standards:</b>	CENELEC EN 60079-0: 2018, EN 60079-1: 2014, EN 60079-7: 2015, EN 60079-15: 2019, EN 60079-31: 2014 and EUROPEAN DIRECTIVE 2014/34/EU IEC60079-0: 2017, IEC60079-1: 2014, IEC60079-7: 2017, IEC60079-15: 2017, IEC60079-31: 2013 RoHS Directive 2002/95/EC	
<b>Operating temperature:</b>	-60 °C +130 °C	
<b>Protection rating:</b>	IP66/68 (30 meters - 12 hours)	
<b>Design</b>	BS 6121: Part 1:1989, IEC 62444, EN 62444	

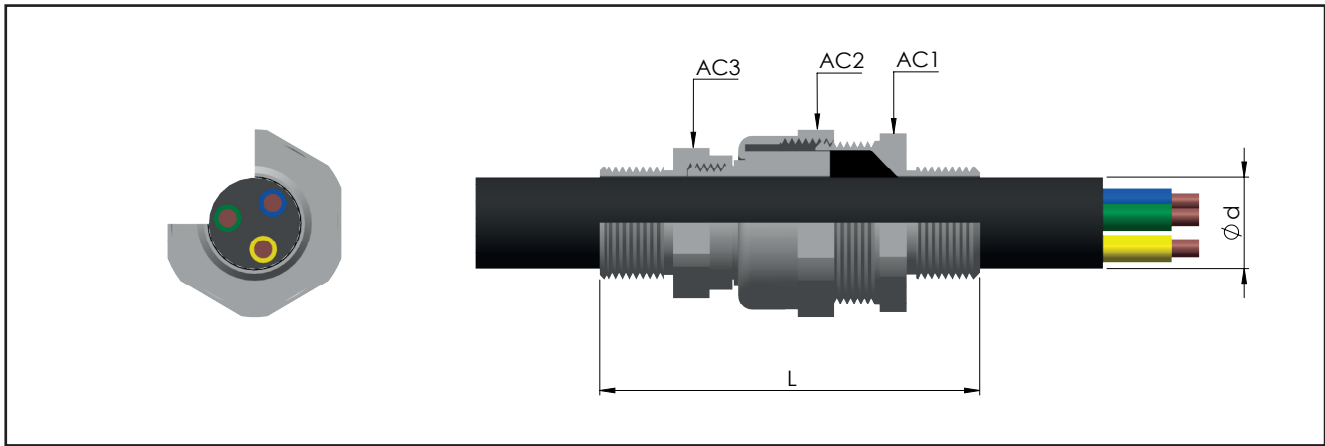
Certificates are available on [www.elfit.com](http://www.elfit.com)

ACCESSORIES UPON REQUEST				
Locknuts	ISO thread	Nickel-plated brass	Galvanized steel	Stainless steel
	M12x1,5	DL02IB	DL02IG	DL02IS
	M16x1,5	DL01IB	DL01IG	DL01IS
	M20x1,5	DL1IB	DL1IG	DL1IS
	M25x1,5	DL2IB	DL2IG	DL2IS
	M32x1,5	DL3IB	DL3IG	DL3IS
	M40x1,5	DL4IB	DL4IG	DL4IS
	M50x1,5	DL5IB	DL5IG	DL5IS
	M63x1,5	DL6IB	DL6IG	DL6IS
	M75x1,5	DL7IB	DL7IG	DL7IS
	M90x1,5	DL8IB	DL8IG	DL8IS
	M100x1,5	DL10IB	DL10IG	DL10IS
	M115x1,5	DL115IB	DL115IG	DL115IS

Nickel-plated brass earthing rings	ISO thread	Nickel-plated brass	Stainless steel	Serrated stainless steel lock washers	Code	Adapters and reducers of the RE... series
	M12x1,5	A0231IB	A0231IS		RD101S/A4 RD11S/A4 RD12IS/A4 RD13IS/A4 RD14IS/A4 RD15IS/A4 RD16IS/A4	
	M16x1,5	A0131IB	A0131IS			
	M20x1,5	A131IB	A131IS			
	M25x1,5	A231IB	A231IS			
	M32x1,5	A331IB	A331IS			
	M40x1,5	A431IB	A431IS			
	M50x1,5	A531IB	A531IS			
	M63x1,5	A631IB	A631IS			
	M75x1,5	A731IB	A731IS			
	M90x1,5	A831IB	A831IS			
	M100x1,5	A1031IB	A1031IS			
	M115x1,5	A1031B	A1031S			

\* For different threads, contact the sales department.

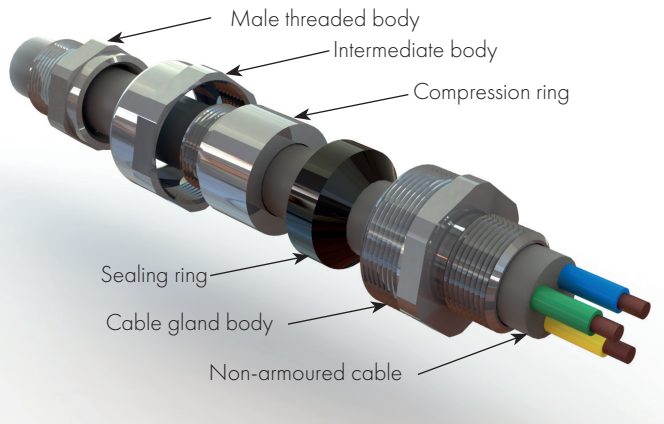
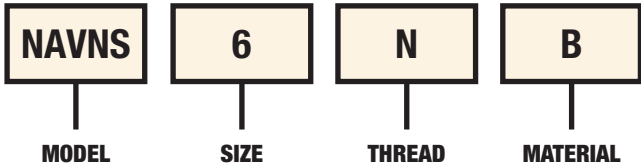




CABLE GLAND SELECTION TABLE									
Code Nickel-plated brass	Thread	Code Nickel-plated brass	Thread	Dimensions in mm				Range	Weight
				AC1	AC2	AC3	L	Ød min-max Outer sheath of the cable	Kg
NAVNS02NB	1/4" NPT	NAVNS12IB	M12x1,5	18	18	20	63.5	3.0 - 6.0	0,120
NAVNS01NB	3/8" NPT	NAVNS16IB	M16x1,5	24	24	20	64	3.5 - 8.6	0,172
NAVNS1SNB	1/2" NPT	NAVNS20SIB	M20x1,5	24	26	20	64	6.3 - 11.6	0,193
NAVNS1NB	1/2" NPT	NAVNS20IB	M20x1,5	30	32	24	67	6.5 - 14	0,250
NAVNS2NB	3/4" NPT	NAVNS25IB	M25x1,5	36	38	30	67	11 - 20	0,277
NAVNS3NB	1" NPT	NAVNS32IB	M32x1,5	45	47	38	70	17 - 27	0,471
NAVNS4NB	1 1/4" NPT	NAVNS40IB	M40x1,5	50	52	45	70	22 - 32	0,604
NAVNS5SNB	1 1/2" NPT	NAVNS50SIB	M50x1,5	55	57	52	73	29.5 - 38	0,748
NAVNS5NB	2" NPT	NAVNS50IB	M50x1,5	60	62	52	73	35.5 - 44	0,725
NAVNS6SNB	2" NPT	NAVNS63SIB	M63x1,5	68	77	64	83	40 - 50	1,361
NAVNS6NB	2 1/2" NPT	NAVNS63IB	M63x1,5	73	77	64	84	47 - 56	1,184
NAVNS7SNB	2 1/2" NPT	NAVNS75SIB	M75x1,5	80	82	82	87	53 - 62	1,478
NAVNS7NB	3" NPT	NAVNS75IB	M75x1,5	85	90	80	88	59 - 68	1,235
NAVNS8NB	3" NPT	NAVNS90IB	M90x1,5	100	110	90	97	66 - 79	2,466
NAVNS9NB	3 1/2" NPT	NAVNS100IB	M100x1,5	115	120	100	100	76 - 91	2,687
NAVNS10NB	4" NPT	NAVNS115IB	M115x1,5	120	130	115	100	86 - 98	3,702

\* Dimensions with threaded: NPT / ISO

Sample order code

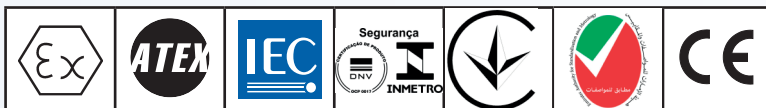


TECHNICAL NOTES:

- Silicone o-rings are supplied for cylindrical threads (ISO metric) for the pre-assembled IP seal on the cable gland
- The ISO7/1 thread version is available upon request (sample code NAVNS1B)
- Also available in stainless steel AISI 316 (sample code NAVNS1S)
- Other materials on request
- For "Ex i" intrinsic safety version, RAL 5015 blue nut (sample code NAVNS1IA)

**Cable gland series NEV for armoured cables from 1/4" to 4"**

NEV series cable glands are suitable for use in areas with the risk of explosion, allowing the direct insertion of armoured cables in explosion proof enclosures. They are supplied with a sealing ring which is stretched over the cable at the inlet ensuring the anti-loosening, 'Ex d' execution, and a second compression ring which is stretched over the cable armour at the outlet to guarantee an IP 66/68 protection rating. The result is a cable gland which provides maximum performance in terms of reliability and safety over time, is compatible with a wide range of the main, commercially available cables, and complies with the most recent applicable regulations. Their structure makes them suitable for environments which are particularly difficult, such as marine environments, or where there are subjected to the mechanical stresses and impacts which often occur in heavy industry, where safety is the utmost priority.



See Video with assembly instructions for NEV.. (light armoured)



See Video with assembly instructions for NEV.. (heavy armoured)

<b>Classification:</b> 2014/34/EU	<b>Group II</b>	<b>Category 2GD/3G</b>
<b>Installation:</b> EN 60079.14	<b>zone 1 - zone 2 (Gas)</b>	<b>zone 21 - zone 22 (Dust)</b>
<b>Marking:</b>	CE 0722 Ex II 2 GD - Ex db IIC Gb - Ex eb IIC Gb II 2 D - Ex tb IIC Db II 3G Ex nR IIC Gc - IP66/68	
<b>Certification:</b>	<b>ATEX (category 2):</b>	<b>IMQ 17 ATEX 016X</b>
	<b>ATEX (category 3):</b>	<b>IMQ 17 ATEX 017X</b>
<b>Standards:</b>	<b>IEC Ex</b>	<b>IECEX IMQ 17.0010X</b>
	For IEC Ex and others certifications data can be downloaded at <a href="http://www.elfit.com">www.elfit.com</a>	
<b>Operating temperature:</b>	<b>-60 °C +130 °C</b>	
<b>Protection rating:</b>	<b>IP66/68 (30 meters - 12 hours)</b>	
<b>Design</b>	<b>BS 6121: Part 1:1989, IEC 62444, EN 62444</b>	

Certificates are available on [www.elfit.com](http://www.elfit.com)

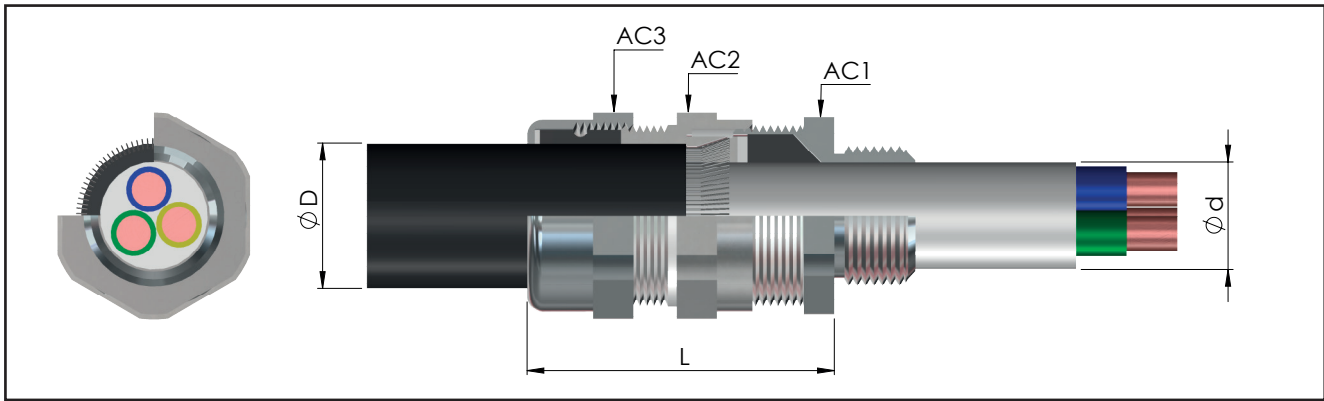
**ACCESSORIES UPON REQUEST**

Locknuts	ISO thread	Nickel-plated brass	Galvanized steel	Stainless steel	Sealing ring for flat/healing cables	Black TPV protector	Cableglands	Code	
	M12x1,5	<b>DL02IB</b>	<b>DL02IG</b>	<b>DL02IS</b>			NEV01NB	NEV16IB	<b>PGA1F</b>
	M16x1,5	<b>DL01IB</b>	<b>DL01IG</b>	<b>DL01IS</b>			NEV1SNB	NEV20SIB	<b>PGA1N</b>
	M20x1,5	<b>DL1IB</b>	<b>DL1IG</b>	<b>DL1IS</b>			NEV1NB	NEV20IB	<b>PGA1</b>
	M25x1,5	<b>DL2IB</b>	<b>DL2IG</b>	<b>DL2IS</b>			NEV2NB	NEV25IB	<b>PGA2N</b>
	M32x1,5	<b>DL3IB</b>	<b>DL3IG</b>	<b>DL3IS</b>			NEV3NB	NEV32IB	<b>PGA4</b>
	M40x1,5	<b>DL4IB</b>	<b>DL4IG</b>	<b>DL4IS</b>			NEV4NB	NEV40IB	<b>PGA4</b>
	M50x1,5	<b>DL5IB</b>	<b>DL5IG</b>	<b>DL5IS</b>			NEV5SNB	NEV50SIB	<b>PGA5</b>
	M63x1,5	<b>DL6IB</b>	<b>DL6IG</b>	<b>DL6IS</b>			NEV5NB	NEV50IB	<b>PGA5N</b>
	M75x1,5	<b>DL7IB</b>	<b>DL7IG</b>	<b>DL7IS</b>			NEV6SNB	NEV63SIB	<b>PGA6</b>
	M90x1,5	<b>DL8IB</b>	<b>DL8IG</b>	<b>DL8IS</b>			NEV6NB	NEV63IB	<b>PGA7</b>
	M100x1,5	<b>DL10IB</b>	<b>DL10IG</b>	<b>DL10IS</b>			NEV7SNB	NEV75SIB	<b>GTR7</b> Heat shrinkable
	M115x1,5	<b>DL115IB</b>	<b>DL115IG</b>	<b>DL115IS</b>			NEV7NB	NEV75IB	
				NEV8NB	NEV90IB				
							NEV9NB	NEV100IB	
							NEV10NB	NEV115IB	

Nickel-plated brass earthing rings	ISO thread	Nickel-plated brass	Stainless steel	Serrated stainless steel lock washers	Code	Adapters and reducers of the RE... series
	M12x1,5	<b>A0231IB</b>	<b>A0231IS</b>		<b>RD102IS/A4</b>	
	M16x1,5	<b>A0131IB</b>	<b>A0131IS</b>		<b>RD101IS/A4</b>	
	M20x1,5	<b>A131IB</b>	<b>A131IS</b>		<b>RD11IS/A4</b>	
	M25x1,5	<b>A231IB</b>	<b>A231IS</b>		<b>RD12IS/A4</b>	
	M32x1,5	<b>A331IB</b>	<b>A331IS</b>		<b>RD13IS/A4</b>	
	M40x1,5	<b>A431IB</b>	<b>A431IS</b>		<b>RD14IS/A4</b>	
	M50x1,5	<b>A531IB</b>	<b>A531IS</b>		<b>RD15IS/A4</b>	
	M63x1,5	<b>A631IB</b>	<b>A631IS</b>		<b>RD16IS/A4</b>	
	M75x1,5	<b>A731IB</b>	<b>A731IS</b>			
	M90x1,5	<b>A831IB</b>	<b>A831IS</b>			
	M100x1,5	<b>A1031IB</b>	<b>A1031IS</b>			
	M115x1,5	<b>A1031IB</b>	<b>A1031IS</b>			

\* For different threads, contact the sales department.

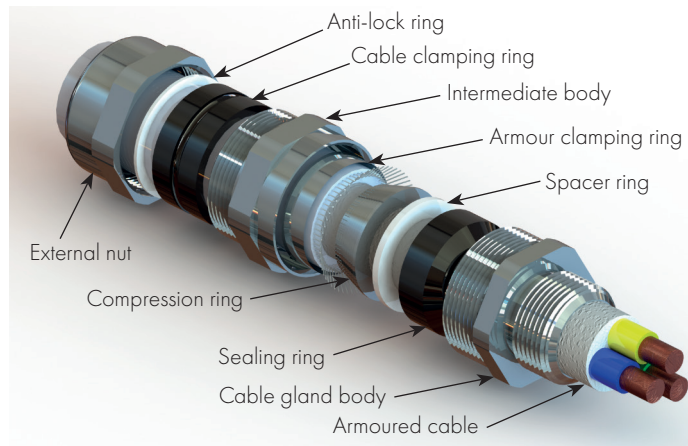
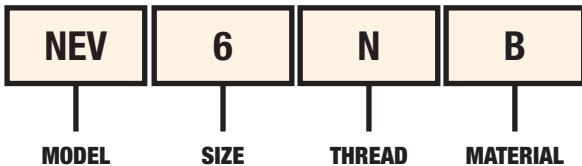


**CABLE GLAND SELECTION TABLE**

Code Nickel-plated brass	Thread	Code Nickel-plated brass	Thread	Dimensions in mm				Range		Armour thickness	Weight Kg
				AC1	AC2	AC3	L	Ød min-max Internal cable sheath	ØD min-max Outer sheath of the cable		
NEV02NB	1/4" NPT	NEV12IB	M12x1,5	18	18	18	58	3.0 - 6.0	6 - 10.0	0.2 - 1.3	0,100
NEV01NB	3/8" NPT	NEV16IB	M16x1,5	24	24	24	59	3.5 - 8.6	6 - 13.2	0.2 - 1.3	0,145
NEV1SNB	1/2" NPT	NEV20SIB	M20x1,5	24	26	26	59	6.3 - 11.6	9.5 - 16	0.2 - 1.3	0,157
NEV1NB	1/2" NPT	NEV20IB	M20x1,5	30	32	32	61	6.5 - 14	12.5 - 21	0.2 - 1.4	0,215
NEV2NB	3/4" NPT	NEV25IB	M25x1,5	36	38	38	61	11 - 20	20 - 27.5	0.2 - 1.6	0,261
NEV3NB	1" NPT	NEV32IB	M32x1,5	45	47	47	72	17 - 27	23.5 - 34	0.2 - 2.0	0,433
NEV4NB	1 1/4" NPT	NEV40IB	M40x1,5	50	52	52	73	22 - 32	26 - 40	0.2 - 2.2	0,514
NEV5SNB	1 1/2" NPT	NEV50SIB	M50x1,5	55	57	57	80	29.5 - 38	35 - 46.5	0.2 - 2.5	0,610
NEV5NB	2" NPT	NEV50IB	M50x1,5	62/60*	62	62	81	35.5 - 44	38 - 53	0.2 - 2.5	0,562
NEV6SNB	2" NPT	NEV63SIB	M63x1,5	68	75	77	91	40 - 50	45.5 - 59.5	0.2 - 2.5	1,151
NEV6NB	2 1/2" NPT	NEV63IB	M63x1,5	75/73*	80	82	93	47 - 56	54.5 - 66	0.2 - 2.5	1,100
NEV7SNB	2 1/2" NPT	NEV75SIB	M75x1,5	80	85	90	97	53 - 62	57 - 72	0.2 - 2.8	1,308
NEV7NB	3" NPT	NEV75IB	M75x1,5	90/85*	95	100	99	59 - 68	66.5 - 78.5	0.2 - 2.8	1,538
NEV8NB	3" NPT	NEV90IB	M90x1,5	100	105	110	104	66 - 79	76.5 - 90	0.2 - 2.8	2,000
NEV9NB	3 1/2" NPT	NEV100IB	M100x1,5	115	120	120	111	76 - 91	86 - 101	0.2 - 3.3	2,381
NEV10NB	4" NPT	NEV115IB	M115x1,5	120	125	130	112	86 - 98	100 - 110	0.2 - 3.5	2,783

\* Dimensions with threaded: NPT / ISO

**Sample order code**

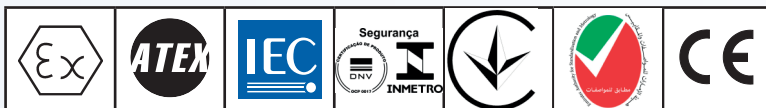


**TECHNICAL NOTES:**

- Silicone o-rings are supplied for cylindrical threads (ISO metric) for the pre-assembled IP seal on the cable gland
- The ISO7/1 thread version is available upon request (sample code NEV1B)
- Also available in stainless steel AISI 316 (sample code NEV1S)
- Other materials on request
- For "Ex i" intrinsic safety version, RAL 5015 blue nut (sample code NEV1SIA)
- Internal ring for armoured cables with larger cross-section

## Cable gland series NEVL for lead sheathed armoured cables

NEVL series cable glands are suitable for use in areas with the risk of explosion, allowing the direct insertion of armoured cables in explosion proof enclosures and the installation of lead sheathed cables. They are supplied with a sealing ring which is stretched over the cable at the inlet ensuring the anti-loosening, 'Ex d' execution, and a second compression ring which is stretched over the cable armour at the outlet to guarantee an IP 66/68 protection rating, and a metal ring which affixes to the outer surface of the lead sheath as it is wound, fastening it in place. Their structure makes them suitable for environments which are particularly difficult, such as marine environments, or where there are subjected to the mechanical stresses and impacts which often occur in heavy industry, where safety is the utmost priority.



[Safety, use and maintenance instructions](#)

<b>Classification:</b> 2014/34/EU	Group II	Category 2GD/3G
<b>Installation:</b> EN 60079-14	zone 1 - zone 2 (Gas)	zone 21 - zone 22 (Dust)
<b>Marking:</b>	CE 0722 Ex II 2 GD - Ex db IIC Gb - Ex eb IIC Gb II 2 D - Ex tb IIIC Db II 3G Ex nR IIC Gc - IP66/68	
<b>Certification:</b>	ATEX (category 2):	IMQ 17 ATEX 016X
	ATEX (category 3):	IMQ 17 ATEX 017X
<b>Standards:</b>	IEC Ex	IECEX IMQ 17.0010X
	For IEC Ex and others certifications data can be downloaded at <a href="http://www.elfit.com">www.elfit.com</a>	
<b>Operating temperature:</b>	-60 °C +130 °C	
<b>Protection rating:</b>	IP66/68 (30 meters - 12 hours)	
<b>Design</b>	BS 6121: Part 1:1989, IEC 62444, EN 62444	

Certificates are available on [www.elfit.com](http://www.elfit.com)

### ACCESSORIES UPON REQUEST

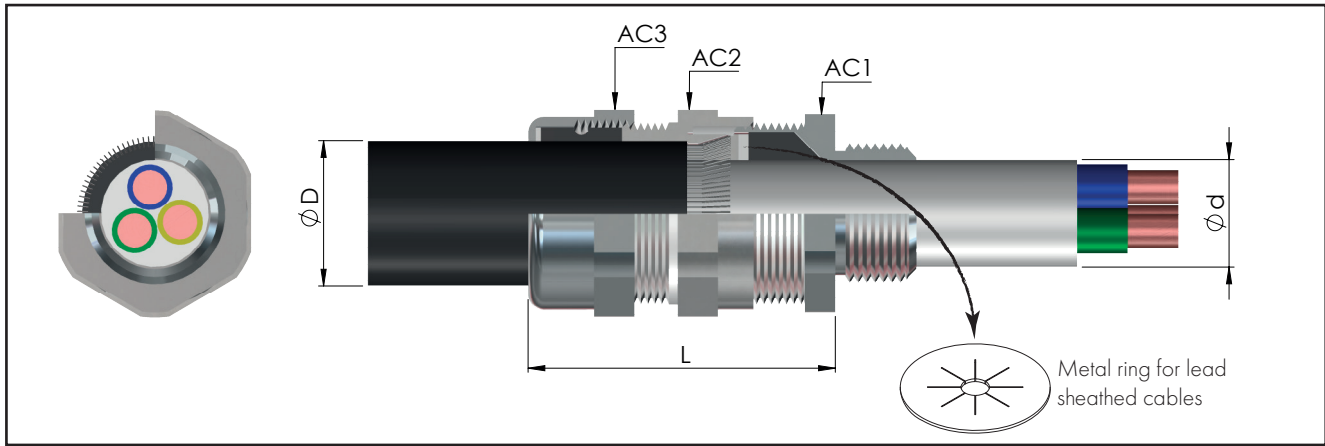
Locknuts	ISO thread	Nickel-plated brass	Galvanized steel	Stainless steel	Sealing ring for flat/healing cables	Black TPV protector	CG	Code
	M12x1,5	DL02IB	DL02IG	DL02IS			NEVL01NB	PGA1F
	M16x1,5	DL01IB	DL01IG	DL01IS			NEVL1SNB	PGA1N
	M20x1,5	DL1IB	DL1IG	DL1IS			NEVL1NB	PGA1
	M25x1,5	DL2IB	DL2IG	DL2IS			NEVL2NB	PGA2N
	M32x1,5	DL3IB	DL3IG	DL3IS			NEVL3NB	PGA4
	M40x1,5	DL4IB	DL4IG	DL4IS			NEVL4NB	PGA5
	M50x1,5	DL5IB	DL5IG	DL5IS			NEVL5SNB	PGA5
	M63x1,5	DL6IB	DL6IG	DL6IS			NEVL5NB	PGA5N
	M75x1,5	DL7IB	DL7IG	DL7IS			NEVL6SNB	PGA6
	M90x1,5	DL8IB	DL8IG	DL8IS			NEVL6NB	PGA7
	M100x1,5	DL10IB	DL10IG	DL10IS			NEVL7SNB	GTR Heat shrinkable
M115x1,5	DL115IB	DL115IG	DL115IS	NEVL7NB				
				NEVL8NB				
						NEVL9NB		
						NEVL10NB		

Nickel-plated brass earthing rings	ISO thread	Nickel-plated brass	Stainless steel	Serrated stainless steel lock washers	Code	Adapters and reducers of the RE... series
	M12x1,5	A0231B	A0231S		RD102IS/A4	
	M16x1,5	A0131B	A0131S		RD101IS/A4	
	M20x1,5	A131B	A131S		RD11IS/A4	
	M25x1,5	A231B	A231S		RD12IS/A4	
	M32x1,5	A331B	A331S		RD13IS/A4	
	M40x1,5	A431B	A431S		RD14IS/A4	
	M50x1,5	A531B	A531S		RD15IS/A4	
	M63x1,5	A631B	A631S		RD16IS/A4	
	M75x1,5	A731B	A731S			
	M90x1,5	A831B	A831S			
	M100x1,5	A1031B	A1031S			
M115x1,5	A1031B	A1031S				

\* For different threads, contact the sales department.



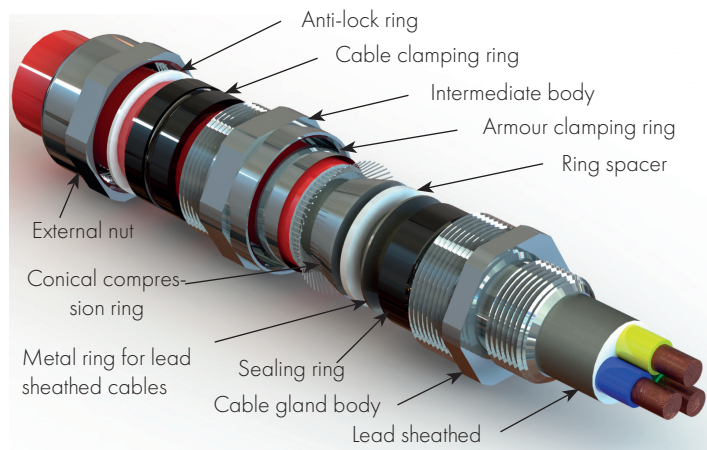
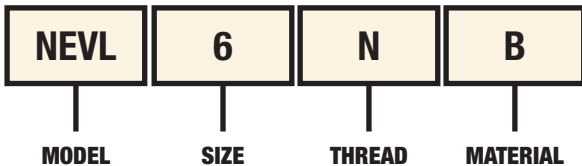


**CABLE GLAND SELECTION TABLE**

Code Nickel-plated brass	Thread	Code Nickel-plated brass	Thread	Dimensions in mm				Range		Armour thickness	Weight Kg
				AC1	AC2	AC3	L	Ød min-max Internal cable sheath	ØD min-max Outer sheath of the cable		
NEVL02NB	1/4" NPT	NEVL12IB	M12x1,5	18	18	18	59	3.0 - 6.0	6 - 10.0	0.2 - 1.3	0,100
NEVL01NB	3/8" NPT	NEVL16IB	M16x1,5	24	24	24	59	3.5 - 8.6	6 - 13.2	0.2 - 1.3	0,145
NEVL1SNB	1/2" NPT	NEVL20SIB	M20x1,5	24	26	26	59	6.3 - 11.6	9.5 - 16	0.2 - 1.3	0,157
NEVL1NB	1/2" NPT	NEVL20IB	M20x1,5	30	32	32	61	6.5 - 14	12.5 - 21	0.2 - 1.4	0,215
NEVL2NB	3/4" NPT	NEVL25IB	M25x1,5	36	38	38	61	11 - 20	20 - 27.5	0.2 - 1.6	0,261
NEVL3NB	1" NPT	NEVL32IB	M32x1,5	45	47	47	72	17 - 27	23.5 - 34	0.2 - 2.0	0,433
NEVL4NB	1 1/4" NPT	NEVL40IB	M40x1,5	50	52	52	73	22 - 32	26 - 40	0.2 - 2.2	0,514
NEVL5SNB	1 1/2" NPT	NEVL50SIB	M50x1,5	55	57	57	80	29.5 - 38	35 - 46.5	0.2 - 2.5	0,610
NEVL5NB	2" NPT	NEVL50IB	M50x1,5	62/60*	62	62	81	35.5 - 44	38 - 53	0.2 - 2.5	0,562
NEVL6SNB	2" NPT	NEVL63SIB	M63x1,5	68	75	77	91	40 - 50	45.5 - 59.5	0.2 - 2.5	1,151
NEVL6NB	2 1/2" NPT	NEVL63IB	M63x1,5	75/73*	80	82	93	47 - 56	54.5 - 66	0.2 - 2.5	1,100
NEVL7SNB	2 1/2" NPT	NEVL75SIB	M75x1,5	80	85	90	97	53 - 62	57 - 72	0.2 - 2.8	1,308
NEVL7NB	3" NPT	NEVL75IB	M75x1,5	90/85*	95	100	99	59 - 68	66.5 - 78.5	0.2 - 2.8	1,538
NEVL8NB	3" NPT	NEVL90IB	M90x1,5	100	105	110	104	66 - 79	76.5 - 90	0.2 - 2.8	2,000
NEVL9NB	3 1/2" NPT	NEVL100IB	M100x1,5	115	120	120	111	76 - 91	86 - 101	0.2 - 3.3	2,381
NEVL10NB	4" NPT	NEVL115IB	M115x1,5	120	125	130	112	86 - 98	100 - 110	0.2 - 3.5	2,783

\* Dimensions with threaded: NPT / ISO

**Sample order code**



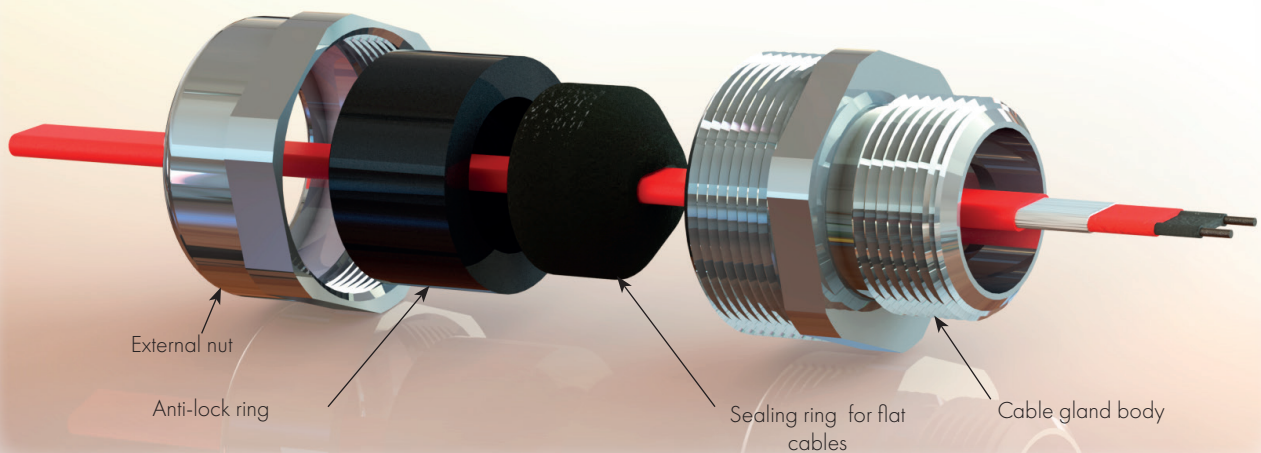
**TECHNICAL NOTES:**

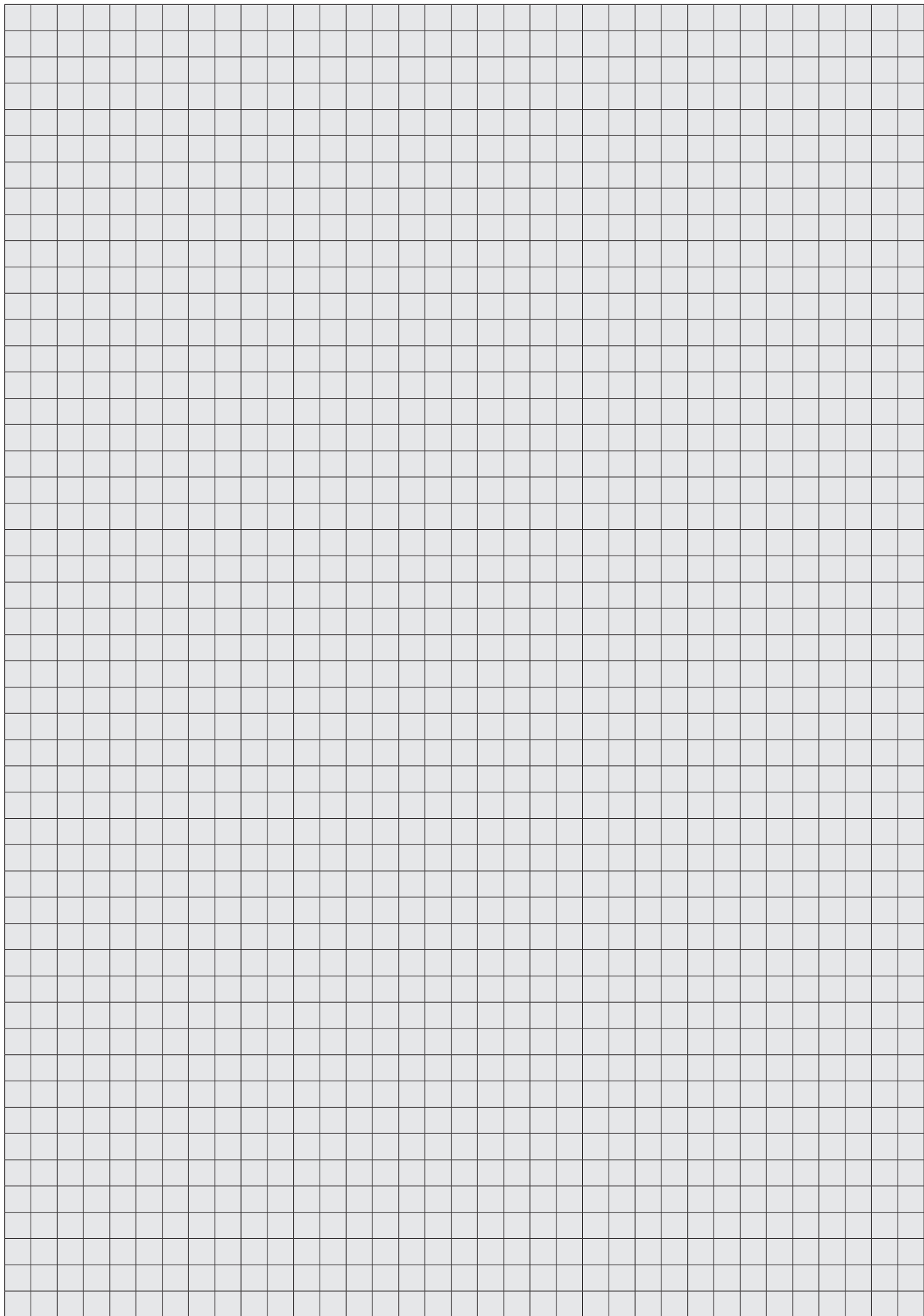
- Silicone o-rings are supplied for cylindrical threads (ISO metric) for the pre-assembled IP seal on the cable gland
- The ISO7/1 thread version is available upon request (sample code NEVL1B)
- Also available in stainless steel AISI 316 (sample code NEVL1S)
- Other materials on request
- For "Ex i" intrinsic safety version, RAL 5015 blue nut (sample code NEVL1SIA)
- Internal ring for armoured cables with larger cross-section

Cable glands for non-armoured cables: Sealing ring for flat / heating cables



Cable gland type		E	F	Code
NAV..01N..	NAV..16I..	7.7	5.5	<b>H01-567</b>
NAV..1SN..	NAV..20SI..	7.7	5.5	<b>H1S-567/1</b>
NAV..1SN..	NAV..20SI..	8.7	3.5	<b>H1S-567/2</b>
NAV..1SN..	NAV..20SI..	9.7	4.1	<b>H1S-567/3</b>
NAV..1SN..	NAV..20SI..	10.2	4.1	<b>H1S-567/4</b>
NAV..1SN..	NAV..20SI..	10.7	4.6	<b>H1S-567/5</b>
NAV..1SN..	NAV..20SI..	10.7	5.1	<b>H1S-567/6</b>
NAV..1SN..	NAV..20SI..	10.7	6.1	<b>H1S-567/7</b>
NAV..1N..	NAV..20I..	7.7	5.5	<b>H1-567/1</b>
NAV..1N..	NAV..20I..	8.7	3.5	<b>H1-567/2</b>
NAV..1N..	NAV..20I..	9.7	4.1	<b>H1-567/3</b>
NAV..1N..	NAV..20I..	10.2	4.1	<b>H1-567/4</b>
NAV..1N..	NAV..20I..	10.5	5.5	<b>H1-567/45</b>
NAV..1N..	NAV..20I..	10.7	4.6	<b>H1-567/5</b>
NAV..1N..	NAV..20I..	10.7	5.1	<b>H1-567/6</b>
NAV..1N..	NAV..20I..	10.7	6.1	<b>H1-567/7</b>
NAV..1N..	NAV..20I..	11.7	5.6	<b>H1-567/8</b>
NAV..1N..	NAV..20I..	13.3	7.6	<b>H1-567/9</b>
NAV..2N..	NAV..25I..	7.7	5.5	<b>H2-567/1</b>
NAV..2N..	NAV..25I..	8.7	3.5	<b>H2-567/2</b>
NAV..2N..	NAV..25I..	9.7	4.1	<b>H2-567/3</b>
NAV..2N..	NAV..25I..	10.2	4.1	<b>H2-567/4</b>
NAV..2N..	NAV..25I..	10.5	5.5	<b>H2-567/45</b>
NAV..2N..	NAV..25I..	10.7	4.6	<b>H2-567/5</b>
NAV..2N..	NAV..25I..	10.7	5.1	<b>H2-567/6</b>
NAV..2N..	NAV..25I..	10.7	6.1	<b>H2-567/7</b>
NAV..2N..	NAV..25I..	11.7	5.6	<b>H2-567/8</b>
NAV..2N..	NAV..25I..	15.4	5.5	<b>H2-567/9</b>





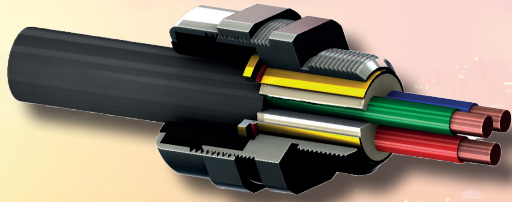


## Types of barrier cable glands

Illustration

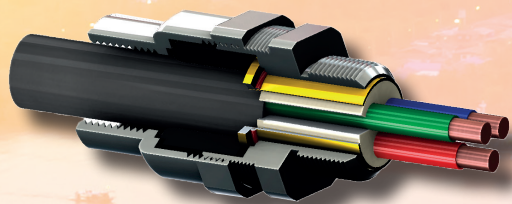
Code

Description



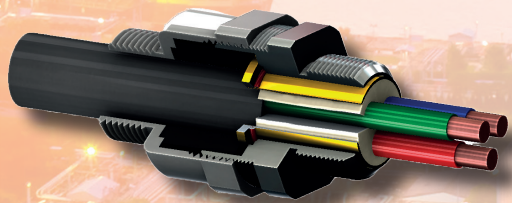
NAVB

Cable gland for non-armoured cables from 3/8" to 4"



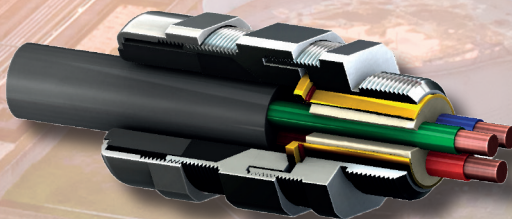
NAVBF

Cable gland for non-armoured cables from 3/8" to 4" with a female threaded outlet fitting



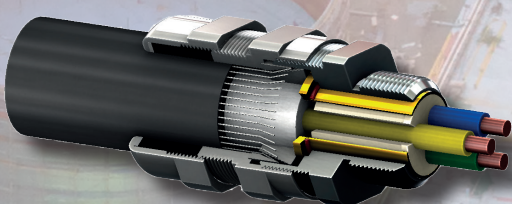
NAVBN

Cable gland for non-armoured cables from 3/8" to 4" with a male threaded outlet fitting



NAVGB

Cable gland for non-armoured cables from 3/8" to 4"  
Provides a cable retention seal onto the cables outer sheath



NEVB

Cable gland for armoured cables from 3/8" to 4"



1



### SCD system

Cartridge system with resin plus mixer for use with manual dispenser supplied as an option. The best and most comfortable solution for the resin coating of large quantities of cable glands.

Order code cartridge + mixer: BOND-C

Order code dispenser: DISP-C

2



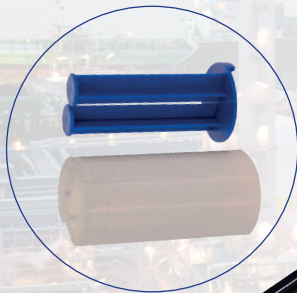
### SBR system

Resin bag system. The most economical way of resin coating for small quantities of cable glands.

Order code 25 ml bag: BOND-B-25

Order code 100 ml bag: BOND-B-100

3



### SAD system

The system with adapters for the use of normal silicone guns (not included) together with resin cartridges and KC mixers.

Order code adapters: ADAP-C

## No resin waste!

Thanks to the exclusive software internally developed, it is possible to receive the exact quantity of resin for the required cable glands supply without incurring the risk of resin waste.

**Cable gland series NAVB for non-armoured cables from 3/8" to 4"**

The NAVB series barrier cable glands for non-armoured cable are designed to guarantee the IP66/67 protection and the explosion protection 'Ex db IIC; Ex eb IIC' in applications where installation requirements are needed in accordance with the EN - IEC 60079-14: 2015 standard. The barrier is shaped around the conductors thanks to the particular mixture that flows through them in the special bushing ensuring a complete seal. The liquid resin used prevents the formation of air pockets or voids between the conductors and the bushing (typical problems found with malleable resins). Resin kit available separately.



[NAVB assembly instructions video](#)

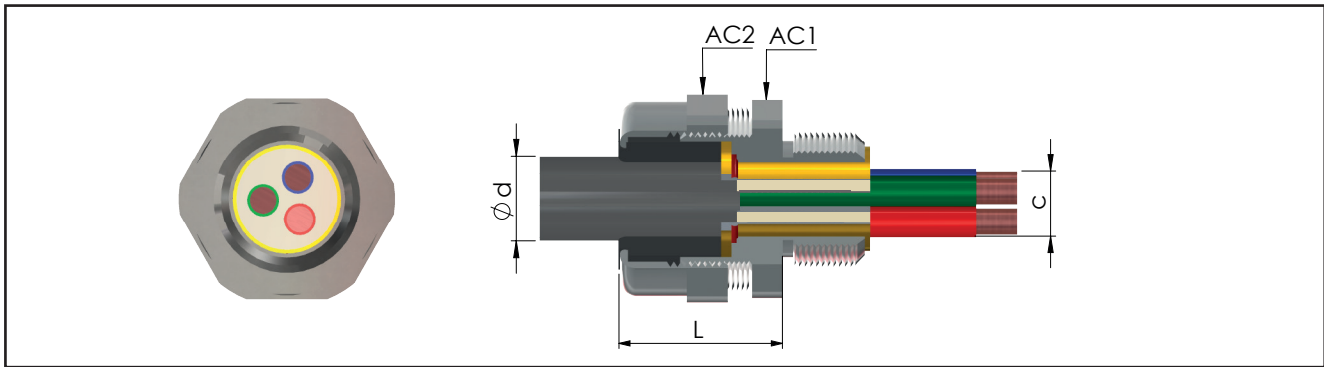
<b>Classification:</b> 2014/34/EU	<b>Group II</b>	<b>Category 2GD/3G</b>
<b>Installation:</b> EN 60079.14	<b>zone 1 - zone 2 (Gas)</b>	<b>zone 21 - zone 22 (Dust)</b>
<b>Marking:</b>	CE 0722 Ex II 2 GD - Ex db IIC Gb - Ex eb IIC Gb II 2 D - Ex tb IIIC Db II 3G Ex nR IIC Gc	
<b>Certification:</b>	<b>ATEX (category 2):</b>	<b>IMQ 19 ATEX 019X</b>
	<b>ATEX (category 3):</b>	<b>IMQ 19 ATEX 020X</b>
	<b>IEC Ex</b>	<b>IECEX IMQ 19.0003X</b>
	<b>TR CU</b>	<b>DISPONIBILE</b>
<b>Standards:</b>	CENELEC EN 60079-0: 2012+A11:2013, EN 60079-1: 2014, EN 60079-7: 2015, EN 60079-15: 2010, EN 60079-31: 2014 ed alla DIRETTIVA EUROPEA 2014/34/UE IEC60079-0: 2011, IEC60079-1: 2014, IEC60079-7: 2015, IEC60079-15: 2010, IEC60079-31: 2013 Direttiva RoHS 2002/95/CE	
<b>Operating temperature:</b>	<b>-60°C +100°C</b>	
<b>Protection rating:</b>	<b>IP66/67</b>	
<b>Design</b>	<b>BS 6121: Part 1:1989, IEC 62444, EN 62444</b>	

Certificates are available on [www.elfit.com](http://www.elfit.com)

ACCESSORIES UPON REQUEST						
Locknuts  	ISO thread	Nickel-plated brass	Galvanized steel	Stainless steel		
	M16x1,5	<b>DL01IB</b>	<b>DL01IG</b>	<b>DL01IS</b>		
	M20x1,5	<b>DL11IB</b>	<b>DL11IG</b>	<b>DL11IS</b>		
	M25x1,5	<b>DL21IB</b>	<b>DL21IG</b>	<b>DL21IS</b>		
	M32x1,5	<b>DL31IB</b>	<b>DL31IG</b>	<b>DL31IS</b>		
	M40x1,5	<b>DL41IB</b>	<b>DL41IG</b>	<b>DL41IS</b>		
	M50x1,5	<b>DL51IB</b>	<b>DL51IG</b>	<b>DL51IS</b>		
	M63x1,5	<b>DL61IB</b>	<b>DL61IG</b>	<b>DL61IS</b>		
	M75x1,5	<b>DL71IB</b>	<b>DL71IG</b>	<b>DL71IS</b>		
	M90x1,5	<b>DL81IB</b>	<b>DL81IG</b>	<b>DL81IS</b>		
M100x1,5	<b>DL10IB</b>	<b>DL10IG</b>	<b>DL10IS</b>			
M115x1,5	<b>DL115IB</b>	<b>DL115IG</b>	<b>DL115IS</b>			
Nickel-plated brass earthing rings  	ISO thread	Nickel-plated brass	Stainless steel	Serrated stainless steel lock washers	Code	Adapters and reducers of the RE... series
	M16x1,5	<b>A0131IB</b>	<b>A0131IS</b>		<b>RD101S/A4</b>	 GTR7 Heat shrinkable
	M20x1,5	<b>A131IB</b>	<b>A131IS</b>		<b>RD11S/A4</b>	
	M25x1,5	<b>A231IB</b>	<b>A231IS</b>		<b>RD12S/A4</b>	
	M32x1,5	<b>A331IB</b>	<b>A331IS</b>		<b>RD13S/A4</b>	
	M40x1,5	<b>A431IB</b>	<b>A431IS</b>		<b>RD14S/A4</b>	
	M50x1,5	<b>A531IB</b>	<b>A531IS</b>		<b>RD15S/A4</b>	
	M63x1,5	<b>A631IB</b>	<b>A631IS</b>		<b>RD16S/A4</b>	
	M75x1,5	<b>A731IB</b>	<b>A731IS</b>			
	M90x1,5	<b>A831IB</b>	<b>A831IS</b>			
M100x1,5	<b>A1031IB</b>	<b>A1031IS</b>				
M115x1,5	<b>A1031IB</b>	<b>A1031IS</b>				

\* For different threads, contact the sales department.





**CABLE GLAND SELECTION TABLE**

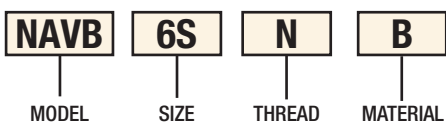
Code Nickel-plated brass	Thread	Code Nickel-plated brass	Thread	Dimensions in mm			Range			Weight Kg	Q.ty of resin ml ***
				AC1	AC2	L	Ød cable max	Øc over cores	n. max cable **		
NAVB01NB	3/8" NPT	NAVB16IB	M16x1,5	24	24	29.5	7.1	5.5	11	0,094	1.3
NAVB1SNB	1/2" NPT	NAVB20SIB	M20x1,5	24	26	30	11.6	10	11	0,093	3.7
NAVB1NB	1/2" NPT	NAVB20IB	M20x1,5	30	32	33	13.2	11	11	0,126	4.2
NAVB2NB	3/4" NPT	NAVB25IB	M25x1,5	36	38	32	18.6	15	21	0,153	8.3
NAVB3NB	1" NPT	NAVB32IB	M32x1,5	45	47	33	25	21	38	0,232	15
NAVB4NB	1 1/4" NPT	NAVB40IB	M40x1,5	50	52	34	31.8	27	59	0,295	24
NAVB5SNB	1 1/2" NPT	NAVB50SIB	M50x1,5	55	57	36	38	33	89	0,374	36
NAVB5NB	2" NPT	NAVB50IB	M50x1,5	62/60*	62	36	42	35	89	0,329	41
NAVB6SNB	2" NPT	NAVB63SIB	M63x1,5	68	77	46.5	50	43	115	0,753	65
NAVB6NB	2 1/2" NPT	NAVB63IB	M63x1,5	75/73*	77	47.5	54	45	115	0,732	70
NAVB7SNB	2 1/2" NPT	NAVB75SIB	M75x1,5	80	82	65/51*	62	53	140	0,714	98
NAVB7NB	3" NPT	NAVB75IB	M75x1,5	90/85*	90	51	65	55	140	0,627	101
NAVB8NB	3" NPT	NAVB90IB	M90x1,5	100	110	53.5	78.1	65	200	1,384	145
NAVB9NB	3 1/2" NPT	NAVB100IB	M100x1,5	115	120	58	86	72	200	1,316	188
NAVB10NB	4" NPT	NAVB115IB	M115x1,5	120	130	57.5	98	85	200	1,937	254

\* Dimensions with threaded: NPT / ISO.

\*\* At least 20% of the internal section of the bushing must be filled with resin.

\*\*\* Maximum quantity of resin calculated with completely empty bushing.

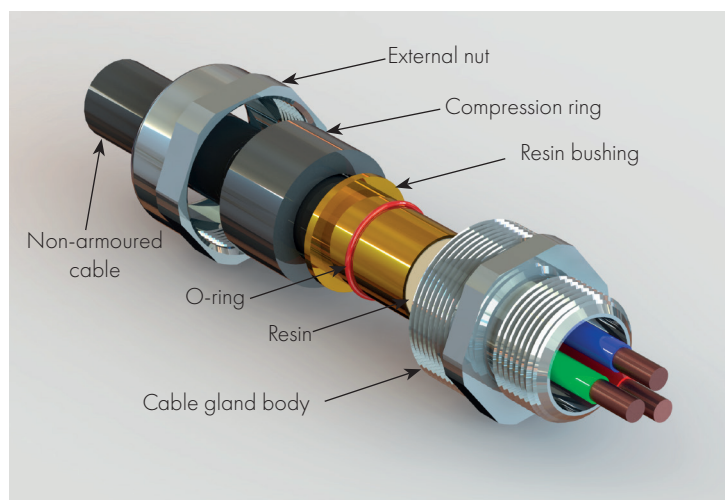
**Sample order code of the cable gland**



Don't forget to order the resin kit with two-component resin (see p. B.19):

- 25 ml resin bag code BOND-B-25
- 100 ml resin bag code BOND-B-100
- 40 ml cartridge + mixing nozzle code BOND-C

(manual dispenser supplied as an option code DISP-C)



**TECHNICAL NOTES:**

- Silicone o-rings are supplied for cylindrical threads (ISO metric) for the pre-assembled IP seal on the cable gland.
- The ISO7/1 thread version is available upon request (sample code NAVB1B).
- Also available in stainless steel AISI 316 (sample code NAVB1S).
- Other materials on request.
- For "Ex i" intrinsic safety version, RAL 5015 blue nut (sample code NAVB1IA).

**Cable gland series NAVBF for non-armoured cables from 3/8" to 4"**

The NAVBF series barrier cable glands for non-armoured cable, with a female threaded outlet fitting, are designed to guarantee the IP66/67 protection and the explosion protection 'Ex db IIC; Ex eb IIC 'in applications where installation requirements are needed in accordance with the EN - IEC 60079-14: 2015 standard. The barrier is shaped around the conductors thanks to the particular mixture that flows through them in the special bushing ensuring a complete seal. The liquid resin used prevents the formation of air pockets or voids between the conductors and the bushing (typical problems found with malleable resins). Resin kit available separately.



[NAVBF assembly instructions video](#)

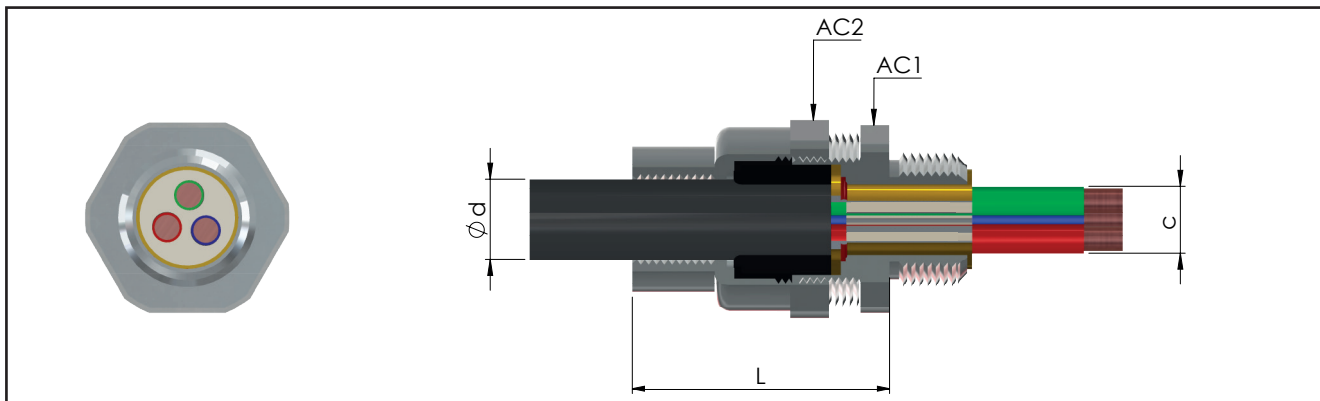
<b>Classification:</b> 2014/34/EU	<b>Group II</b>	<b>Category 2GD/3G</b>
<b>Installation:</b> EN 60079.14	<b>zone 1 - zone 2 (Gas)</b>	<b>zone 21 - zone 22 (Dust)</b>
<b>Marking:</b>	CE 0722 Ex II 2 GD - Ex db IIC Gb - Ex eb IIC Gb II 2 D - Ex tb IIIC Db II 3G Ex nR IIC Gc	
<b>Certification:</b>	<b>ATEX (category 2):</b>	<b>IMQ 19 ATEX 019X</b>
	<b>ATEX (category 3):</b>	<b>IMQ 19 ATEX 020X</b>
	<b>IEC Ex</b>	<b>IECEX IMQ 19.0003X</b>
	<b>TR CU</b>	<b>DISPONIBLE</b>
<b>Standards:</b>	CENELEC EN 60079-0: 2012+A11:2013, EN 60079-1: 2014, EN 60079-7: 2015, EN 60079-15: 2010, EN 60079-31: 2014 and EUROPEAN DIRECTIVE 2014/34/UE IEC60079-0: 2011, IEC60079-1: 2014, IEC60079-7: 2015, IEC60079-15: 2010, IEC60079-31: 2013 RoHS Directive 2002/95/CE	
<b>Operating temperature:</b>	<b>-60°C +100°C</b>	
<b>Protection rating:</b>	<b>IP66/67</b>	
<b>Design</b>	<b>BS 6121: Part 1:1989, IEC 62444, EN 62444</b>	

Certificates are available on [www.elfit.com](http://www.elfit.com)

ACCESSORIES UPON REQUEST								
Locknuts  	ISO thread	Nickel-plated brass	Galvanized steel	Stainless steel	Black TPV protector	Cableglands	Code	
	M16x1,5	<b>DL01IB</b>	<b>DL01IG</b>	<b>DL01IS</b>		NAVBF01NB	NAVBF16IB	<b>PGA1F</b>
	M20x1,5	<b>DL11IB</b>	<b>DL11IG</b>	<b>DL11IS</b>		NAVBF1SNB	NAVBF20SIB	<b>PGA1N</b>
	M25x1,5	<b>DL21IB</b>	<b>DL21IG</b>	<b>DL21IS</b>		NAVBF1NB	NAVBF20IB	<b>PGA1</b>
	M32x1,5	<b>DL31IB</b>	<b>DL31IG</b>	<b>DL31IS</b>		NAVBF2NB	NAVBF25IB	<b>PGA2N</b>
	M40x1,5	<b>DL41IB</b>	<b>DL41IG</b>	<b>DL41IS</b>		NAVBF3NB	NAVBF32IB	<b>PGA4</b>
	M50x1,5	<b>DL51IB</b>	<b>DL51IG</b>	<b>DL51IS</b>		NAVBF4NB	NAVBF40IB	<b>PGA4</b>
	M63x1,5	<b>DL61IB</b>	<b>DL61IG</b>	<b>DL61IS</b>		NAVBF5SNB	NAVBF50SIB	<b>PGA5</b>
	M75x1,5	<b>DL71IB</b>	<b>DL71IG</b>	<b>DL71IS</b>		NAVBF5NB	NAVBF50IB	<b>PGA5N</b>
	M90x1,5	<b>DL81IB</b>	<b>DL81IG</b>	<b>DL81IS</b>		NAVBF6SNB	NAVBF63SIB	<b>PGA6</b>
M100x1,5	<b>DL10IB</b>	<b>DL10IG</b>	<b>DL10IS</b>	NAVBF6NB		NAVBF63IB	<b>PGA6</b>	
M115x1,5	<b>DL115IB</b>	<b>DL115IG</b>	<b>DL115IS</b>	NAVBF7SNB	NAVBF75SIB	<b>PGA7</b>		
Nickel-plated brass earthing rings  	ISO thread	Nickel-plated brass	Stainless steel	Serrated stainless steel lock washers	Code	Adapters and reducers of the RE... series		
	M16x1,5	<b>A0131IB</b>	<b>A0131IS</b>		<b>RD101S/A4</b>		<b>GTR7</b> Heat shrinkable	
	M20x1,5	<b>A131IB</b>	<b>A131IS</b>		<b>RD11S/A4</b>			
	M25x1,5	<b>A231IB</b>	<b>A231IS</b>		<b>RD12S/A4</b>			
	M32x1,5	<b>A331IB</b>	<b>A331IS</b>		<b>RD13S/A4</b>			
	M40x1,5	<b>A431IB</b>	<b>A431IS</b>		<b>RD14S/A4</b>			
	M50x1,5	<b>A531IB</b>	<b>A531IS</b>		<b>RD15S/A4</b>			
	M63x1,5	<b>A631IB</b>	<b>A631IS</b>		<b>RD16S/A4</b>			
	M75x1,5	<b>A731IB</b>	<b>A731IS</b>					
	M90x1,5	<b>A831IB</b>	<b>A831IS</b>					
M100x1,5	<b>A1031IB</b>	<b>A1031IS</b>						
M115x1,5	<b>A1031B</b>	<b>A1031S</b>						

\* For different threads, contact the sales department.





**CABLE GLAND SELECTION TABLE**

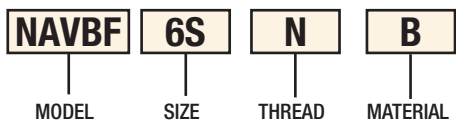
Code Nickel-plated brass	Thread	Code Nickel-plated brass	Thread	Dimensions in mm			Range			Weight Kg	Q.ty of resin ml ***
				AC1	AC2	L	Ød cable max	Øc over cores	n. max cable **		
NAVBF01NB	3/8" NPT	NAVBF16IB	M16x1,5	24	24	48.5	8.6	5.5	11	0,117	1.3
NAVBF1SNB	1/2" NPT	NAVBF20SIB	M20x1,5	24	26	49	11.6	10	11	0,130	3.7
NAVBF1NB	1/2" NPT	NAVBF20IB	M20x1,5	30	32	52.5	14	11	11	0,170	4.2
NAVBF2NB	3/4" NPT	NAVBF25IB	M25x1,5	36	38	51.5	20	15	21	0,233	8.3
NAVBF3NB	1" NPT	NAVBF32IB	M32x1,5	45	47	52.5	27	21	38	0,303	15
NAVBF4NB	1 1/4" NPT	NAVBF40IB	M40x1,5	50	52	53.5	32	27	59	0,401	24
NAVBF5SNB	1 1/2" NPT	NAVBF50SIB	M50x1,5	55	57	56.5	38	33	89	0,530	36
NAVBF5NB	2" NPT	NAVBF50IB	M50x1,5	62/60*	62	56.5	44	35	89	0,470	41
NAVBF6SNB	2" NPT	NAVBF63SIB	M63x1,5	68	77	69	50	43	115	1,079	65
NAVBF6NB	2 1/2" NPT	NAVBF63IB	M63x1,5	75/73*	77	70	56	45	115	0,815	70
NAVBF7SNB	2 1/2" NPT	NAVBF75SIB	M75x1,5	80	82	73.5	62	53	140	0,918	98
NAVBF7NB	3" NPT	NAVBF75IB	M75x1,5	90/85*	90	73.5	68	55	140	1,027	101
NAVBF8NB	3" NPT	NAVBF90IB	M90x1,5	100	110	82	79	65	200	2,071	145
NAVBF9NB	3 1/2" NPT	NAVBF100IB	M100x1,5	115	120	88	91	72	200	2,192	188
NAVBF10NB	4" NPT	NAVBF115IB	M115x1,5	120	130	87.5	98	85	200	2,565	254

\* Dimensions with threaded: NPT / ISO.

\*\* At least 20% of the internal section of the bushing must be filled with resin.

\*\*\* Maximum quantity of resin calculated with completely empty bushing.

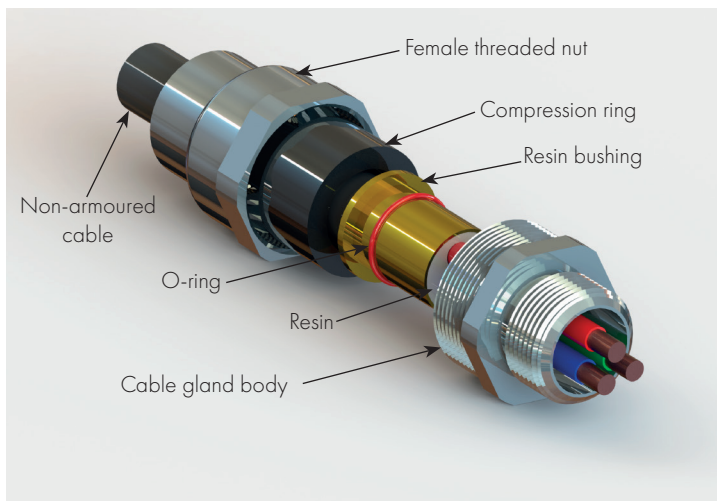
**Sample order code of the cable gland**



Don't forget to order the resin kit with two-component resin (see p. B.19):

- 25 ml resin bag code BOND-B-25
- 100 ml resin bag code BOND-B-100
- 40 ml cartridge + mixing nozzle code BOND-C

(manual dispenser supplied as an option code DISP-C)



**TECHNICAL NOTES:**

- Silicone o-rings are supplied for cylindrical threads (ISO metric) for the pre-assembled IP seal on the cable gland.
- The ISO7/1 thread version is available upon request (sample code NAVBF1B).
- Also available in stainless steel AISI 316 (sample code NAVBF1S).
- Other materials on request.
- For "Ex i" intrinsic safety version, RAL 5015 blue nut (sample code NAVBF1IA).

**Cable gland series NAVBN for non-armoured cables from 3/8" to 4"**

The NAVBN series barrier cable glands for non-armoured cable, with a male threaded outlet fitting, are designed to guarantee the IP66/67 protection and the explosion protection 'Ex db IIC; Ex eb IIC' in applications where installation requirements are needed in accordance with the EN - IEC 60079-14: 2015 standard. The barrier is shaped around the conductors thanks to the particular mixture that flows through them in the special bushing ensuring a complete seal. The liquid resin used prevents the formation of air pockets or voids between the conductors and the bushing (typical problems found with malleable resins). Resin kit available separately.



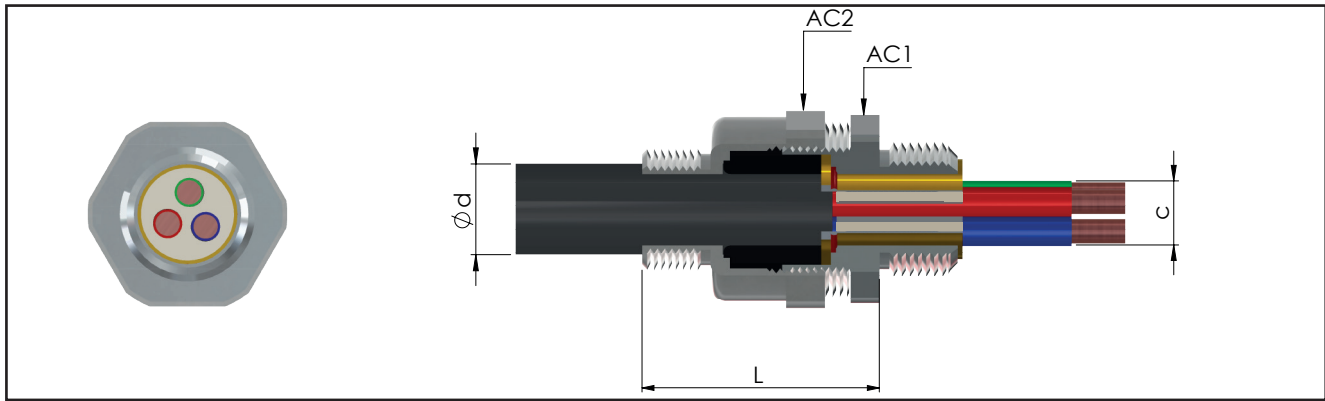
[NAVBN assembly instructions video](#)

<b>Classification:</b> 2014/34/EU	<b>Group II</b>	<b>Category 2GD/3G</b>
<b>Installation:</b> EN 60079.14	<b>zone 1 - zone 2 (Gas)</b>	<b>zone 21 - zone 22 (Dust)</b>
<b>Marking:</b>	CE 0722 Ex II 2 GD - Ex db IIC Gb - Ex eb IIC Gb II 2 D - Ex tb IIIC Db II 3G Ex nR IIC Gc	
<b>Certification:</b>	<b>ATEX (category 2):</b>	<b>IMQ 19 ATEX 019X</b>
	<b>ATEX (category 3):</b>	<b>IMQ 19 ATEX 020X</b>
	<b>IEC Ex</b>	<b>IECEX IMQ 19.0003X</b>
	<b>TR CU</b>	<b>DISPONIBILE</b>
<b>Standards:</b>	CENELEC EN 60079-0: 2012+A11:2013, EN 60079-1: 2014, EN 60079-7: 2015, EN 60079-15: 2010, EN 60079-31: 2014 ed all DIRETTIVA EUROPEA 2014/34/UE IEC60079-0: 2011, IEC60079-1: 2014, IEC60079-7: 2015, IEC60079-15: 2010, IEC60079-31: 2013 Direttiva RoHS 2002/95/CE	
<b>Operating temperature:</b>	<b>-60°C +100°C</b>	
<b>Protection rating:</b>	<b>IP66/67</b>	
<b>Design</b>	<b>BS 6121: Part 1:1989, IEC 62444, EN 62444</b>	

Certificates are available on [www.elfit.com](http://www.elfit.com)

ACCESSORIES UPON REQUEST							
Locknuts  	ISO thread	Nickel-plated brass	Galvanized steel	Stainless steel	Black TPV protector	Cableglands	Code
	M16x1,5	<b>DL01IB</b>	<b>DL01IG</b>	<b>DL01IS</b>		NAVBN01NB NAVBN16IB	<b>PGA1F</b>
	M20x1,5	<b>DL11IB</b>	<b>DL11IG</b>	<b>DL11IS</b>		NAVBN1SNB NAVBN20SIB	<b>PGA1N</b>
	M25x1,5	<b>DL21IB</b>	<b>DL21IG</b>	<b>DL21IS</b>		NAVBN1NB NAVBN20IB	<b>PGA1</b>
	M32x1,5	<b>DL31IB</b>	<b>DL31IG</b>	<b>DL31IS</b>		NAVBN2NB NAVBN25IB	<b>PGA2N</b>
	M40x1,5	<b>DL41IB</b>	<b>DL41IG</b>	<b>DL41IS</b>		NAVBN3NB NAVBN32IB	<b>PGA4</b>
	M50x1,5	<b>DL51IB</b>	<b>DL51IG</b>	<b>DL51IS</b>		NAVBN4NB NAVBN40IB	<b>PGA4</b>
	M63x1,5	<b>DL61IB</b>	<b>DL61IG</b>	<b>DL61IS</b>		NAVBN5SNB NAVBN50SIB	<b>PGA5</b>
	M75x1,5	<b>DL71IB</b>	<b>DL71IG</b>	<b>DL71IS</b>		NAVBN5NB NAVBN50IB	<b>PGA5N</b>
	M90x1,5	<b>DL81IB</b>	<b>DL81IG</b>	<b>DL81IS</b>		NAVBN6SNB NAVBN63SIB	<b>PGA6</b>
M100x1,5	<b>DL10IB</b>	<b>DL10IG</b>	<b>DL10IS</b>	NAVBN6NB NAVBN63IB		<b>PGA6</b>	
M115x1,5	<b>DL115IB</b>	<b>DL115IG</b>	<b>DL115IS</b>	NAVBN7SNB NAVBN75SIB	<b>PGA7</b>		
Nickel-plated brass earthing rings  	ISO thread	Nickel-plated brass	Stainless steel	Serrated stainless steel lock washers	Code	Adapters and reducers of the RE... series	
	M16x1,5	<b>A0131IB</b>	<b>A0131IS</b>		<b>RD101S/A4</b>		
	M20x1,5	<b>A131IB</b>	<b>A131IS</b>		<b>RD11S/A4</b>		
	M25x1,5	<b>A231IB</b>	<b>A231IS</b>		<b>RD12S/A4</b>		
	M32x1,5	<b>A331IB</b>	<b>A331IS</b>		<b>RD13S/A4</b>		
	M40x1,5	<b>A431IB</b>	<b>A431IS</b>		<b>RD14S/A4</b>		
	M50x1,5	<b>A531IB</b>	<b>A531IS</b>		<b>RD15S/A4</b>		
	M63x1,5	<b>A631IB</b>	<b>A631IS</b>		<b>RD16S/A4</b>		
	M75x1,5	<b>A731IB</b>	<b>A731IS</b>				
	M90x1,5	<b>A831IB</b>	<b>A831IS</b>				
M100x1,5	<b>A1031IB</b>	<b>A1031IS</b>					
M115x1,5	<b>A1031IB</b>	<b>A1031IS</b>					

\* For different threads, contact the sales department.



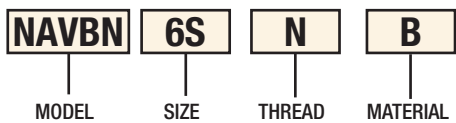
CABLE GLAND SELECTION TABLE												
Code Nickel-plated brass	Thread	Code Nickel-plated brass	Thread	Dimensions in mm			Range			Weight Kg	Q.ty of resin ml ***	
				AC1	AC2	L	Ød cable max	Øc over cores	n. max cable **			
NAVBN01NB	3/8" NPT	NAVBN16IB	M16x1,5	24	24	47.5	8.6	5.5	11	0,115	1.3	
NAVBN1SNB	1/2" NPT	NAVBN20SIB	M20x1,5	24	26	48	11.6	10	11	0,134	3.7	
NAVBN1NB	1/2" NPT	NAVBN20IB	M20x1,5	30	32	51.5	14	11	11	0,165	4.2	
NAVBN2NB	3/4" NPT	NAVBN25IB	M25x1,5	36	38	50.5	20	15	21	0,211	8.3	
NAVBN3NB	1" NPT	NAVBN32IB	M32x1,5	45	47	51.5	27	21	38	0,290	15	
NAVBN4NB	1 1/4" NPT	NAVBN40IB	M40x1,5	50	52	52.5	32	27	59	0,396	24	
NAVBN5SNB	1 1/2" NPT	NAVBN50SIB	M50x1,5	55	57	54.5	38	33	89	0,534	36	
NAVBN5NB	2" NPT	NAVBN50IB	M50x1,5	62/60*	62	54.5	44	35	89	0,431	41	
NAVBN6SNB	2" NPT	NAVBN63SIB	M63x1,5	68	77	67	50	43	115	1,137	65	
NAVBN6NB	2 1/2" NPT	NAVBN63IB	M63x1,5	75/73*	77	68	56	45	115	0,786	70	
NAVBN7SNB	2 1/2" NPT	NAVBN75SIB	M75x1,5	80	82	71.5	62	53	140	1,082	98	
NAVBN7NB	3" NPT	NAVBN75IB	M75x1,5	90/85*	90	71.5	68	55	140	1,042	101	
NAVBN8NB	3" NPT	NAVBN90IB	M90x1,5	100	110	80	79	65	200	1,984	145	
NAVBN9NB	3 1/2" NPT	NAVBN100IB	M100x1,5	115	120	86	91	72	200	2,043	188	
NAVBN10NB	4" NPT	NAVBN115IB	M115x1,5	120	130	85.5	98	85	200	3,056	254	

\* Dimensions with threaded: NPT / ISO.

\*\* At least 20% of the internal section of the bushing must be filled with resin.

\*\*\* Maximum quantity of resin calculated with completely empty bushing.

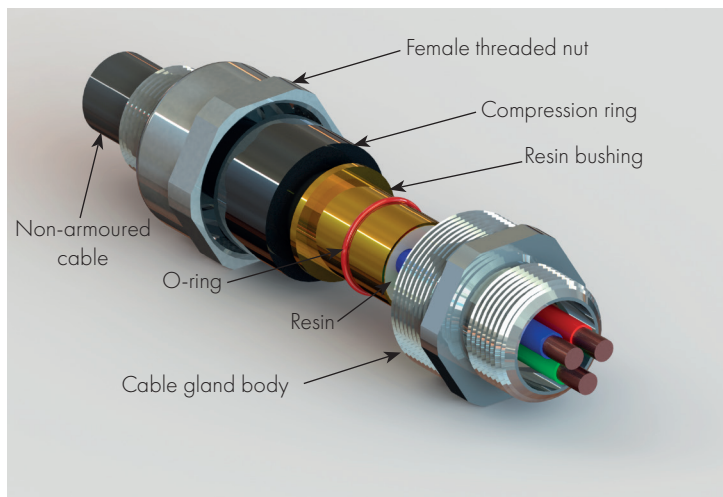
### Sample order code of the cable gland



Don't forget to order the resin kit with two-component resin (see p. B.19):

- 25 ml resin bag code BOND-B-25
- 100 ml resin bag code BOND-B-100
- 40 ml cartridge + mixing nozzle code BOND-C

(manual dispenser supplied as an option code DISP-C)



### TECHNICAL NOTES:

- Silicone o-rings are supplied for cylindrical threads (ISO metric) for the pre-assembled IP seal on the cable gland.
- The ISO7/1 thread version is available upon request (sample code NAVBN1B).
- Also available in stainless steel AISI 316 (sample code NAVBN1S).
- Other materials on request.
- For "Ex i" intrinsic safety version, RAL 5015 blue nut (sample code NAVBN1IA).

**Cable gland series NAVGB for non-armoured cables from 3/8" to 4"**

The NAVGB series barrier cable glands for non-armoured cable are designed to guarantee the IP66/67 protection and the explosion protection 'Ex db IIC; Ex eb IIC' in applications where installation requirements are needed in accordance with the EN - IEC 60079-14: 2015 standard. The NAVGB cable glands are equipped with an additional gasket to tighten the cable inside the cable gland.

The barrier is shaped around the conductors thanks to the particular mixture that flows through them in the special bushing ensuring a complete seal. The liquid resin used prevents the formation of air pockets or voids between the conductors and the bushing (typical problems found with malleable resins). Resin kit available separately.



[NAVGB assembly instructions video](#)

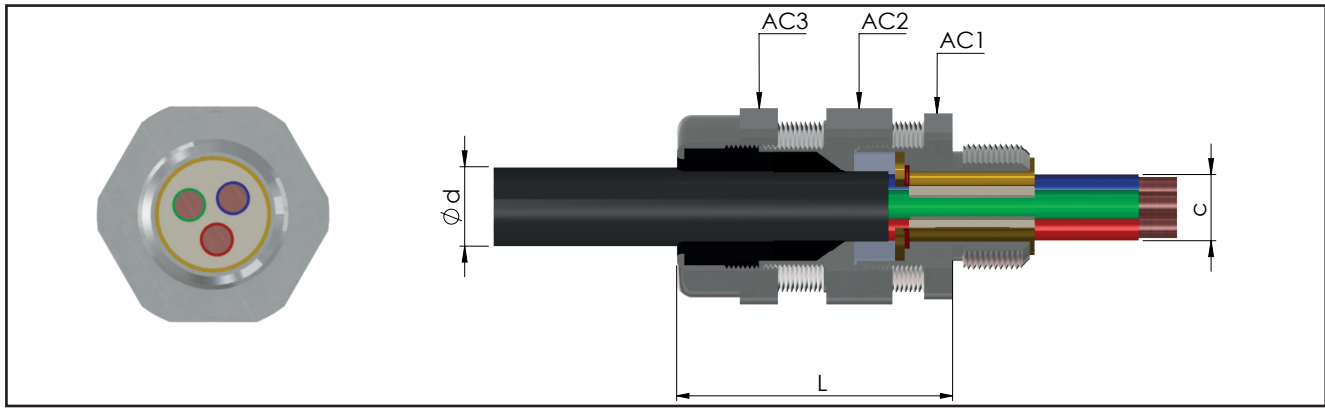
<b>Classification:</b> 2014/34/EU	<b>Group II</b>	<b>Category 2GD/3G</b>
<b>Installation:</b> EN 60079.14	<b>zone 1 - zone 2 (Gas)</b>	<b>zone 21 - zone 22 (Dust)</b>
<b>Marking:</b>	CE 0722 Ex II 2 GD - Ex db IIC Gb - Ex eb IIC Gb II 2 D - Ex tb IIIC Db II 3G Ex nR IIC Gc	
<b>Certification:</b>	<b>ATEX (category 2):</b>	<b>IMQ 19 ATEX 019X</b>
	<b>ATEX (category 3):</b>	<b>IMQ 19 ATEX 020X</b>
	<b>IEC Ex</b>	<b>IECEX IMQ 19.0003X</b>
	<b>TR CU</b>	<b>DISPONIBILE</b>
<b>Standards:</b>	CENELEC EN 60079-0: 2012+A11:2013, EN 60079-1: 2014, EN 60079-7: 2015, EN 60079-15: 2010, EN 60079-31: 2014 ed alla DIRETTIVA EUROPEA 2014/34/UE IEC60079-0: 2011, IEC60079-1: 2014, IEC60079-7: 2015, IEC60079-15: 2010, IEC60079-31: 2013 Direttiva RoHS 2002/95/CE	
<b>Operating temperature:</b>	<b>-60°C +100°C</b>	
<b>Protection rating:</b>	<b>IP66/67</b>	
<b>Design</b>	<b>BS 6121: Part 1:1989, IEC 62444, EN 62444</b>	

Certificates are available on [www.elfit.com](http://www.elfit.com)

ACCESSORIES UPON REQUEST							
Locknuts  	ISO thread	Nickel-plated brass	Galvanized steel	Stainless steel	Black TPV protector	Cableglands	Code
	M16x1,5	<b>DL01IB</b>	<b>DL01IG</b>	<b>DL01IS</b>		NAVGB01NB NAVGB16IB	<b>PGA1F</b>
	M20x1,5	<b>DL11IB</b>	<b>DL11IG</b>	<b>DL11IS</b>		NAVGB1SNB NAVGB20SIB	<b>PGA1N</b>
	M25x1,5	<b>DL21IB</b>	<b>DL21IG</b>	<b>DL21IS</b>		NAVGB1NB NAVGB20IB	<b>PGA1</b>
	M32x1,5	<b>DL31IB</b>	<b>DL31IG</b>	<b>DL31IS</b>		NAVGB2NB NAVGB25IB	<b>PGA2N</b>
	M40x1,5	<b>DL41IB</b>	<b>DL41IG</b>	<b>DL41IS</b>		NAVGB3NB NAVGB32IB	<b>PGA4</b>
	M50x1,5	<b>DL51IB</b>	<b>DL51IG</b>	<b>DL51IS</b>		NAVGB4NB NAVGB40IB	<b>PGA4</b>
	M63x1,5	<b>DL61IB</b>	<b>DL61IG</b>	<b>DL61IS</b>		NAVGB5SNB NAVGB50SIB	<b>PGA5</b>
	M75x1,5	<b>DL71IB</b>	<b>DL71IG</b>	<b>DL71IS</b>		NAVGB5NB NAVGB50IB	<b>PGA5N</b>
	M90x1,5	<b>DL81IB</b>	<b>DL81IG</b>	<b>DL81IS</b>		NAVGB6SNB NAVGB63SIB	<b>PGA6</b>
M100x1,5	<b>DL10IB</b>	<b>DL10IG</b>	<b>DL10IS</b>	NAVGB6NB NAVGB63IB		<b>PGA7</b>	
M115x1,5	<b>DL115IB</b>	<b>DL115IG</b>	<b>DL115IS</b>	NAVGB7SNB NAVGB75SIB	<b>GTR7</b> Heat shrinkable		
				NAVGB7NB NAVGB75IB			
				NAVGB8NB NAVGB90IB			
				NAVGB9NB NAVGB100IB			
				NAVGB10NB NAVGB115IB			
Nickel-plated brass earthing rings  	ISO thread	Nickel-plated brass	Stainless steel	Serrated stainless steel lock washers	Code	Adapters and reducers of the RE... series	
	M16x1,5	<b>A0131IB</b>	<b>A0131IS</b>		<b>RD101S/A4</b>		
	M20x1,5	<b>A131IB</b>	<b>A131IS</b>		<b>RD11S/A4</b>		
	M25x1,5	<b>A231IB</b>	<b>A231IS</b>		<b>RD12S/A4</b>		
	M32x1,5	<b>A331IB</b>	<b>A331IS</b>		<b>RD13S/A4</b>		
	M40x1,5	<b>A431IB</b>	<b>A431IS</b>		<b>RD14S/A4</b>		
	M50x1,5	<b>A531IB</b>	<b>A531IS</b>		<b>RD15S/A4</b>		
	M63x1,5	<b>A631IB</b>	<b>A631IS</b>		<b>RD16S/A4</b>		
	M75x1,5	<b>A731IB</b>	<b>A731IS</b>				
	M90x1,5	<b>A831IB</b>	<b>A831IS</b>				
M100x1,5	<b>A1031IB</b>	<b>A1031IS</b>					
M115x1,5	<b>A1031IB</b>	<b>A1031IS</b>					

\* For different threads, contact the sales department.





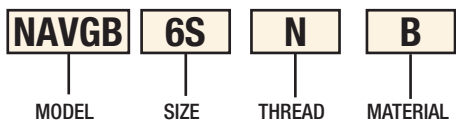
CABLE GLAND SELECTION TABLE												
Code <b>Nickel-plated brass</b>	Thread	Code <b>Nickel-plated brass</b>	Thread	Dimensions in mm				Range			Peso Kg	Q.ty of resin ml ***
				AC1	AC2	AC3	L	Ød cable max	Øc over cores	n. max cable **		
NAVGB01NB	3/8" NPT	NAVGB16IB	M16x1,5	24	24	24	54	3.5 - 8.6	5.5	11	0,130	1.3
NAVGB1SNB	1/2" NPT	NAVGB20SIB	M20x1,5	24	26	26	54	6.3 - 11.6	10	11	0,141	3.7
NAVGB1NB	1/2" NPT	NAVGB20IB	M20x1,5	30	32	32	57	6.5 - 14	11	11	0,193	4.2
NAVGB2NB	3/4" NPT	NAVGB25IB	M25x1,5	36	38	38	57	11 - 20	15	21	0,234	8.3
NAVGB3NB	1" NPT	NAVGB32IB	M32x1,5	45	47	47	62	17 - 27	21	38	0,389	15
NAVGB4NB	1 ¼" NPT	NAVGB40IB	M40x1,5	50	52	52	62	22 - 32	27	59	0,462	24
NAVGB5SNB	1 ½" NPT	NAVGB50SIB	M50x1,5	55	57	57	65	29.5 - 38	33	89	0,549	36
NAVGB5NB	2" NPT	NAVGB50IB	M50x1,5	62/60*	62	62	65	35.5 - 44	35	89	0,505	41
NAVGB6SNB	2" NPT	NAVGB63SIB	M63x1,5	68	75	77	77.5	40 - 50	43	115	1,035	65
NAVGB6NB	2 ½" NPT	NAVGB63IB	M63x1,5	75/73*	80	82	78.5	47 - 56	45	115	0,990	70
NAVGB7SNB	2 ½" NPT	NAVGB75SIB	M75x1,5	80	85	90	84	53 - 62	53	140	1,177	98
NAVGB7NB	3" NPT	NAVGB75IB	M75x1,5	90/85*	95	100	85	59 - 68	55	140	1,384	101
NAVGB8NB	3" NPT	NAVGB90IB	M90x1,5	100	105	110	91	66 - 79	65	200	1,800	145
NAVGB9NB	3 ½" NPT	NAVGB100IB	M100x1,5	115	120	120	94	76 - 91	72	200	2,142	188
NAVGB10NB	4" NPT	NAVGB115IB	M115x1,5	120	125	130	93.5	86 - 98	85	200	2,504	254

\* Dimensions with threaded: NPT / ISO

\*\* At least 20% of the internal section of the bushing must be filled with resin.

\*\*\* Maximum quantity of resin calculated with completely empty bushing.

### Sample order code of the cable gland

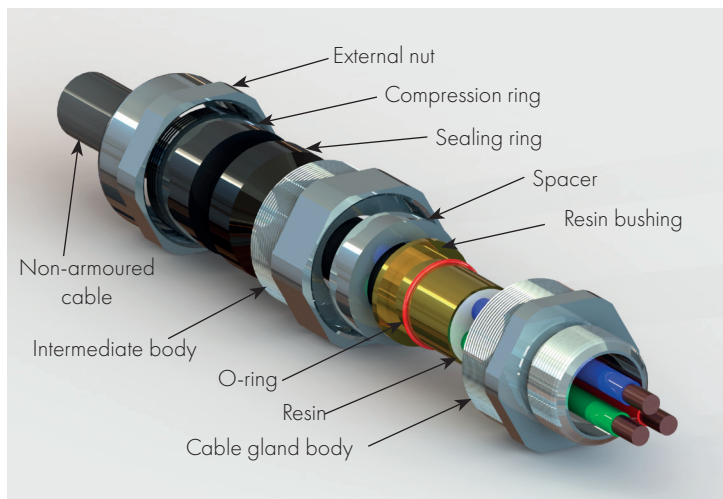


Cartridge  
Mixing nozzle  
Dispenser

Don't forget to order the resin kit with two-component resin (see p. B.19):

- 25 ml resin bag code BOND-B-25
- 100 ml resin bag code BOND-B-100
- 40 ml cartridge + mixing nozzle code BOND-C

(manual dispenser supplied as an option code DISP-C)



### TECHNICAL NOTES:

- Silicone o-rings are supplied for cylindrical threads (ISO metric) for the pre-assembled IP seal on the cable gland.
- The ISO7/1 thread version is available upon request (sample code NAVGB1B).
- Also available in stainless steel AISI 316 (sample code NAVGB1S).
- Other materials on request.

**Cable gland series NEVB for armoured cables from 3/8" to 4"**

The NEVB series barrier cable glands for armoured cable are designed to guarantee the IP66/67 protection and the explosion protection 'Ex db IIC; Ex eb IIC 'in applications where installation requirements are needed in accordance with the EN - IEC 60079-14: 2015 standard. The barrier is shaped around the conductors thanks to the particular mixture that flows through them in the special bushing ensuring a complete seal. The liquid resin used prevents the formation of air pockets or voids between the conductors and the bushing (typical problems found with malleable resins). Resin kit available separately.



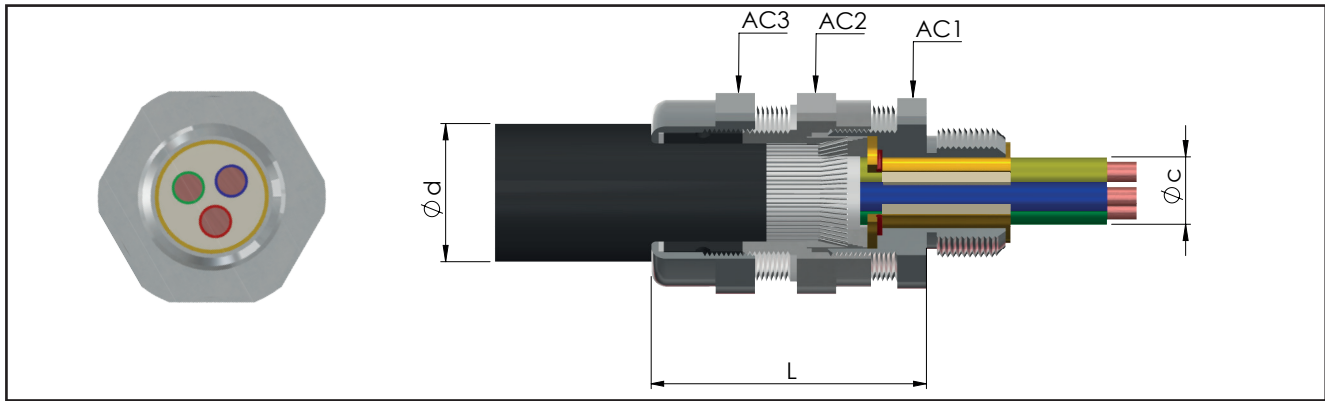
[NEVB assembly instructions video](#)

<b>Classification:</b> 2014/34/EU	<b>Group II</b>	<b>Category 2GD/3G</b>
<b>Installation:</b> EN 60079.14	<b>zone 1 - zone 2 (Gas)</b>	<b>zone 21 - zone 22 (Dust)</b>
<b>Marking:</b>	CE 0722 Ex II 2 GD - Ex db IIC Gb - Ex eb IIC Gb II 2 D - Ex tb IIIC Db II 3G Ex nR IIC Gc	
<b>Certification:</b>	<b>ATEX (category 2):</b>	<b>IMQ 19 ATEX 019X</b>
	<b>ATEX (category 3):</b>	<b>IMQ 19 ATEX 020X</b>
	<b>IEC Ex</b>	<b>IECEX IMQ 19.0003X</b>
	For IEC Ex and others certifications data can be downloaded at <a href="http://www.elfit.com">www.elfit.com</a>	
<b>Standards:</b>	CENELEC EN 60079-0: 2012+A11:2013, EN 60079-1: 2014, EN 60079-7: 2015, EN 60079-15: 2010, EN 60079-31: 2014 ed alla DIRETTIVA EUROPEA 2014/34/UE IEC60079-0: 2011, IEC60079-1: 2014, IEC60079-7: 2015, IEC60079-15: 2010, IEC60079-31: 2013 Direttiva RoHS 2002/95/CE	
<b>Operating temperature:</b>	<b>-60°C +100°C</b>	
<b>Protection rating:</b>	<b>IP66/67</b>	
<b>Design</b>	<b>BS 6121: Part 1:1989, IEC 62444, EN 62444</b>	

Certificates are available on [www.elfit.com](http://www.elfit.com)

ACCESSORIES UPON REQUEST										
Locknuts  	ISO thread	Nickel-plated brass	Galvanized steel	Stainless steel			Black TPV protector  	Cableglands		Code
	M16x1,5	DL01IB	DL01IG	DL01IS				NEVB01NB	NEVB16IB	PGA1F
	M20x1,5	DL11IB	DL11IG	DL11IS				NEVB1SNB	NEVB20SIB	PGA1N
	M25x1,5	DL21IB	DL21IG	DL21IS				NEVB1NB	NEVB20IB	PGA1
	M32x1,5	DL31IB	DL31IG	DL31IS				NEVB2NB	NEVB25IB	PGA2N
	M40x1,5	DL41IB	DL41IG	DL41IS				NEVB3NB	NEVB32IB	PGA4
	M50x1,5	DL51IB	DL51IG	DL51IS				NEVB4NB	NEVB40IB	PGA4
	M63x1,5	DL61IB	DL61IG	DL61IS				NEVB5SNB	NEVB50SIB	PGA5
	M75x1,5	DL71IB	DL71IG	DL71IS				NEVB5NB	NEVB50IB	PGA5N
	M90x1,5	DL81IB	DL81IG	DL81IS				NEVB6SNB	NEVB63SIB	PGA6
M100x1,5	DL10IB	DL10IG	DL10IS			NEVB6NB	NEVB63IB	PGA7		
M115x1,5	DL115IB	DL115IG	DL115IS			NEVB7SNB	NEVB75SIB	GTR7 Heat shrinkable		
M115x1,5	DL115IB	DL115IG	DL115IS			NEVB7NB	NEVB75IB			
M115x1,5	DL115IB	DL115IG	DL115IS			NEVB8NB	NEVB90IB			
M115x1,5	DL115IB	DL115IG	DL115IS			NEVB9NB	NEVB100IB			
M115x1,5	DL115IB	DL115IG	DL115IS			NEVB10NB	NEVB115IB			
Nickel-plated brass earthing rings  	ISO thread	Nickel-plated brass	Stainless steel	Serrated stainless steel lock washers	Code	Adapters and reducers of the RE... series				
	M16x1,5	A0131IB	A0131IS		RD101S/A4					
	M20x1,5	A131IB	A131IS		RD11S/A4					
	M25x1,5	A231IB	A231IS		RD12S/A4					
	M32x1,5	A331IB	A331IS		RD13S/A4					
	M40x1,5	A431IB	A431IS		RD14S/A4					
	M50x1,5	A531IB	A531IS		RD15S/A4					
	M63x1,5	A631IB	A631IS		RD16S/A4					
	M75x1,5	A731IB	A731IS							
	M90x1,5	A831IB	A831IS							
M100x1,5	A1031IB	A1031IS								
M115x1,5	A1031IB	A1031IS								

\* For different threads, contact the sales department.



**CABLE GLAND SELECTION TABLE**

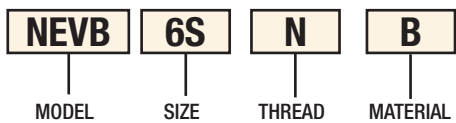
Code Nickel-plated brass	Thread	Code Nickel-plated brass	Thread	Dimensions in mm				Range			Peso Kg	Q.ty of resin ml ***
				AC1	AC2	AC3	L	Ød cable max	Øc over cores	n. max cable **		
NEVB01NB	3/8" NPT	NEVB16IB	M16x1,5	24	24	24	52	6 - 13.2	5.5	11	0,159	1.3
NEVB1SNB	1/2" NPT	NEVB20SIB	M20x1,5	24	26	26	53	9.5 - 16	10	11	0,172	3.7
NEVB1NB	1/2" NPT	NEVB20IB	M20x1,5	30	32	32	59	12.5 - 21	11	11	0,236	4.2
NEVB2NB	3/4" NPT	NEVB25IB	M25x1,5	36	38	38	55	20 - 27.5	15	21	0,287	8.3
NEVB3NB	1" NPT	NEVB32IB	M32x1,5	45	47	47	63	23.5 - 34	21	38	0,476	15
NEVB4NB	1 1/4" NPT	NEVB40IB	M40x1,5	50	52	52	65	26 - 40	27	59	0,565	24
NEVB5SNB	1 1/2" NPT	NEVB50SIB	M50x1,5	55	57	57	69	35 - 46.5	33	89	0,671	36
NEVB5NB	2" NPT	NEVB50IB	M50x1,5	60	62	62	69	38 - 53	35	89	0,618	41
NEVB6SNB	2" NPT	NEVB63SIB	M63x1,5	68	75	77	81	45.5 - 59.5	43	115	1,266	65
NEVB6NB	2 1/2" NPT	NEVB63IB	M63x1,5	73	80	82	83	54.5 - 66	45	115	1,210	70
NEVB7SNB	2 1/2" NPT	NEVB75SIB	M75x1,5	80	85	90	87	57 - 72	53	140	1,438	98
NEVB7NB	3" NPT	NEVB75IB	M75x1,5	85	95	100	88	66.5 - 78.5	55	140	1,691	101
NEVB8NB	3" NPT	NEVB90IB	M90x1,5	100	105	110	92	76.5 - 90	65	200	2,200	145
NEVB9NB	3 1/2" NPT	NEVB100IB	M100x1,5	115	120	120	100	86 - 101	72	200	2,619	188
NEVB10NB	4" NPT	NEVB115IB	M115x1,5	120	125	130	100	100 - 110	85	200	3,061	254

\* Dimensions with threaded: NPT / ISO.

\*\* At least 20% of the internal section of the bushing must be filled with resin.

\*\*\* Maximum quantity of resin calculated with completely empty bushing.

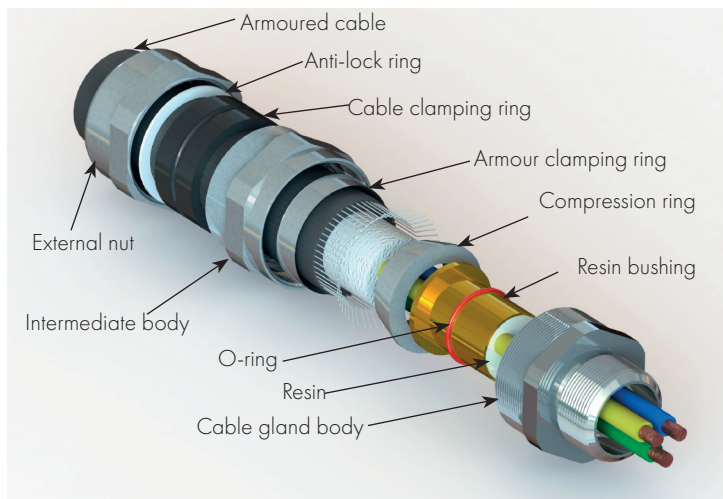
**Sample order code of the cable gland**



Don't forget to order the resin kit with two-component resin (see p. B.19):

- 25 ml resin bag code BOND-B-25
- 100 ml resin bag code BOND-B-100
- 40 ml cartridge + mixing nozzle code BOND-C

(manual dispenser supplied as an option code DISP-C)



**TECHNICAL NOTES:**

- Silicone o-rings are supplied for cylindrical threads (ISO metric) for the pre-assembled IP seal on the cable gland.
- The ISO7/1 thread version is available upon request (sample code NEVB1B).
- Also available in stainless steel AISI 316 (sample code NEVB1S).
- Other materials on request.
- For "Ex i" intrinsic safety version, RAL 5015 blue nut (sample code NEVB1IA).

**Cable glands series NAVP in polyamide for non-armoured cable**

NAVP series cable glands in polyamide with ISO thread are used in hazardous areas to allow direct insertions of non-armoured cables into Ex e (NAVP..IXE) or Ex i (NAVP..IXI) equipment or junction boxes. They can be installed easily, they are strikes resistant until 7J and they ensure Ex e and IP protection on the cable external sheath.



[NAVP assembly instructions video](#)

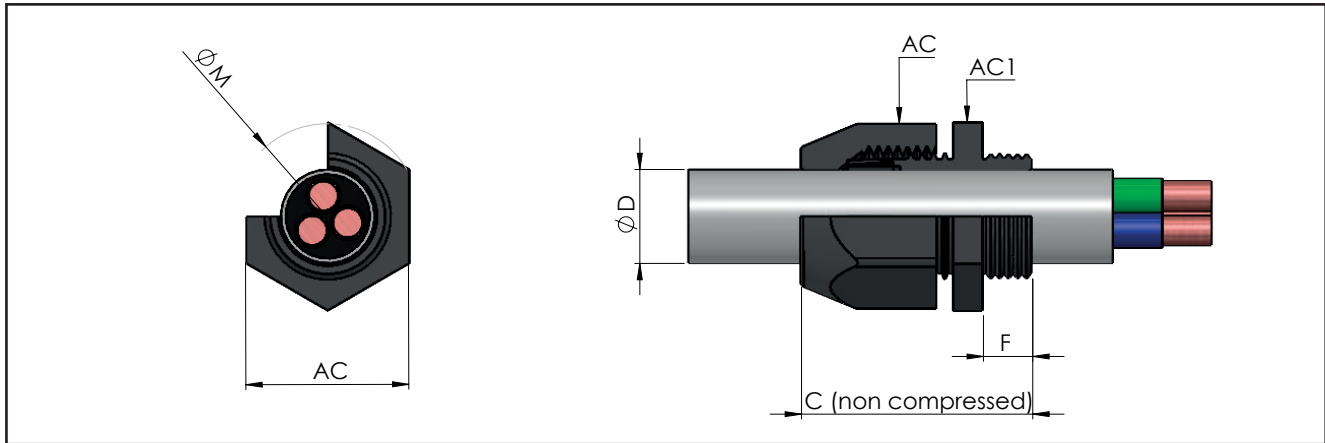
<b>Classification:</b> 2014/34/UE	<b>Group II</b>	<b>Category 2GD</b>
<b>Installation:</b> EN 60079.14	<b>zone 1 - zone 2 (Gas)</b>	<b>zone 21 - zone 22 (Dust)</b>
<b>Marking:</b>	<b>CE 0722 Ex II 2 GD - Ex eb IIC Gb Ex tb IIIC Db IP66/68 *</b>	
<b>Certification:</b>	<b>ATEX</b>	<b>IMQ 16 ATEX 005X</b>
	<b>IECEX</b>	<b>IECEX IMQ 15.0009X</b>
<b>Standards:</b>	CENELEC EN 60079-0: 2012/13, EN 60079-7: 2015, EN 60079-11: 2012, EN 60079-31: 2014 ed alla DIRETTIVA EUROPEA 2014/34/UE IEC 60079-0: 2011, IEC 60079-7: 2015, IEC 60079-11: 2011, IEC 60079-31: 2013 Direttiva RoHS 2002/95/CE	
<b>Operating temperature:</b>	<b>-60°C +70°C</b>	
<b>Degree of protection:</b>	<b>IP66/68 (50 meters - 30 minutes)</b>	

Certificates are available on [www.elfit.com](http://www.elfit.com)

\* Ex e IIC cable glands can be used with Ex i circuits. The nut of these cable gland shall be painted blue and marking will not be changed. The nut of these cable gland shall be painted blue and marking will not be changed.

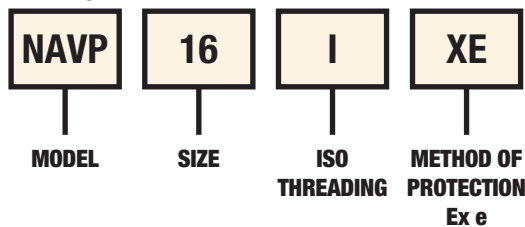
Accessories upon request						
Locknut	ISO thread	Code	Material	Plugs for IP protection	ISO thread	Code
	M12x1,5	<b>DL02IXEP</b>	Polyamide		M12x1,5	<b>PT02N</b>
	M16x1,5	<b>DL01IXEP</b>			M16x1,5	<b>PT01N</b>
	M20x1,5	<b>DL1IXEP</b>			M20x1,5	<b>PT1N</b>
	M25x1,5	<b>DL2IXEP</b>			M25x1,5	<b>PT2N</b>
	M32x1,5	<b>DL3IXEP</b>			M32x1,5	<b>PT3N</b>
	M40x1,5	<b>DL4IXEP</b>			M40x1,5	<b>PT4N</b>
	M50x1,5	<b>DL5IXEP</b>			M50x1,5	<b>PT5N</b>
	M63x1,5	<b>DL6IXEP</b>			M63x1,5	<b>PT6N</b>





CABLE GLANDS SELECTION TABLE									
Code <b>Polyamide</b>	Method of protection	Thread	Dimensions in mm					Range	Weight
			AC	AC1	ØM	F	C	ØD min-max	Kg
NAV12IXE	Ex e	M12x1,5	15	15	17	10	32	4 - 6,5	0,004
NAV16IXE		M16x1,5	22	22	25	15	44,5	6 - 10	0,006
NAV20IXE		M20x1,5	24	24	28	15	45	7 - 12	0,010
NAV25IXE-X6DS		M25x1,5	33	33	38	15	50	10 - 18	0,016
NAV25IXE		M25x1,5	33	33	38	15	50	14 - 18	0,016
NAV32IXE		M32x1,5	42	42	48	15	55,5	19 - 25	0,042
NAV40IXE		M40x1,5	53	53	60	18	68	23 - 32	0,074
NAV50IXE		M50x1,5	60	60	69	18	72	31 - 38	-
NAV63IXE		M63x1,5	65	65	75	18	72	35 - 44	-
NAV12IXI	Ex i	M12x1,5	15	15	17	10	32	4 - 6,5	0,004
NAV16IXI		M16x1,5	22	22	25	15	44,5	6 - 10	0,006
NAV20IXI		M20x1,5	24	24	28	15	45	7 - 12	0,010
NAV25IXI		M25x1,5	33	33	38	15	50	14 - 18	0,016
NAV32IXI		M32x1,5	42	42	48	15	55,5	19 - 25	0,042
NAV40IXI		M40x1,5	53	53	60	18	68	23 - 32	0,074
NAV50IXI		M50x1,5	60	60	69	18	72	31 - 38	-
NAV63IXI		M63x1,5	65	65	75	18	72	35 - 44	-

**Example of Order Code**



**TECHNICAL NOTES:**

- Silicone gaskets
- Color of cable gland black RAL 9005 (Ex e) or blue RAL 5015 (Ex i)
- Strikes resistant 7J

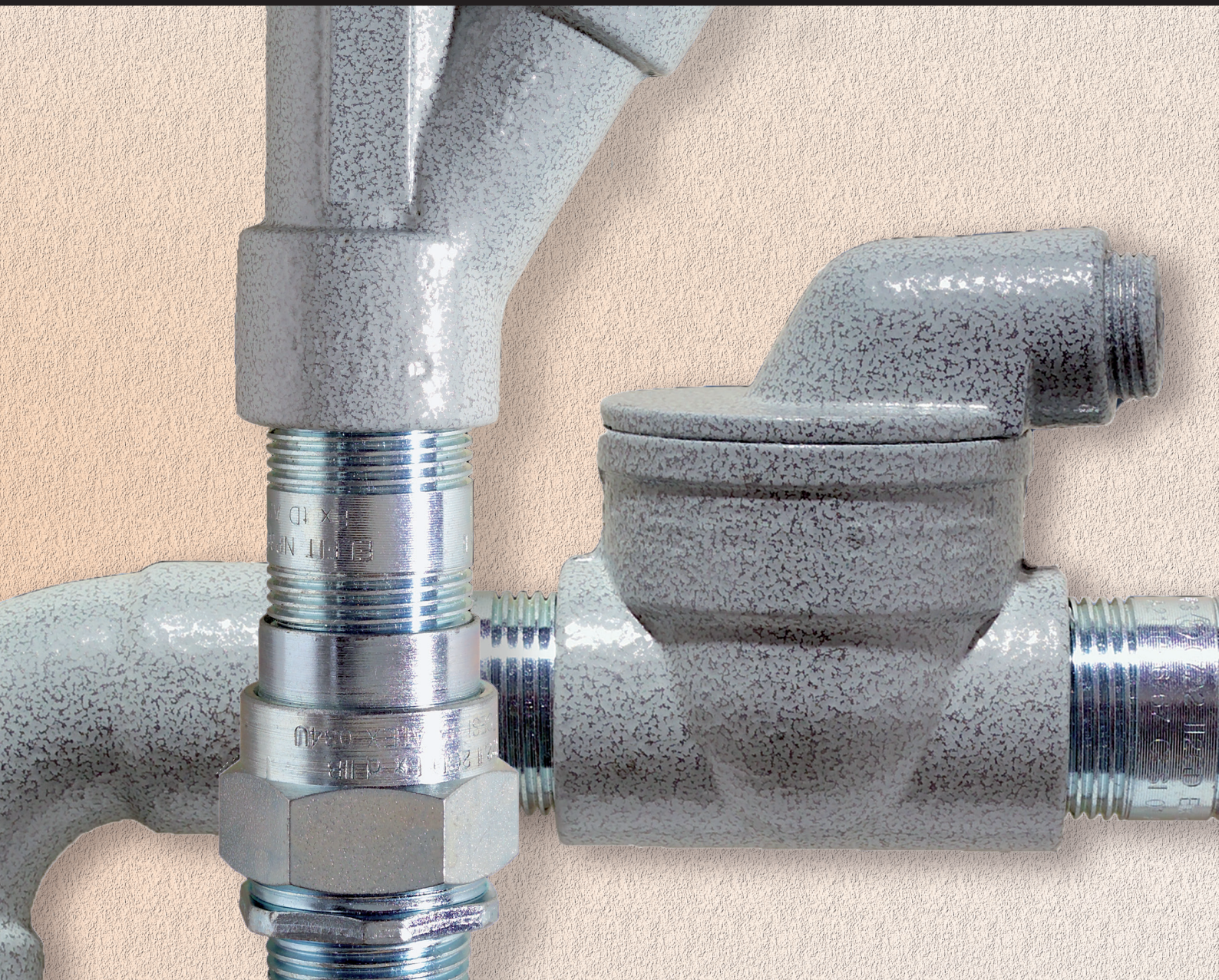
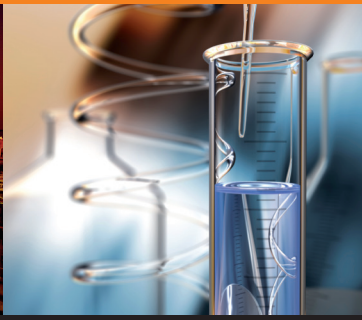




# ELFIT<sup>®</sup>

Electrical FITtings

## Electrical fittings for electrical plants





BMF series three pieces unions for IIB gas group enable an independent rotation and the connection between pipes, enclosures or different equipment.



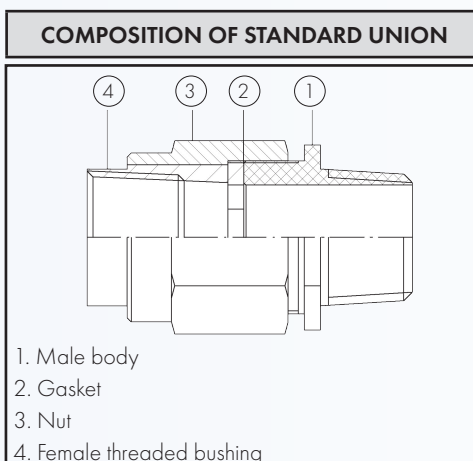
<b>Classification:</b> 2014/34/UE	Group II	Category 2GD
<b>Installation:</b> EN 60079.14	zone 1 - zone 2 (Gas)	zone 21 - zone 22 (Dust)
<b>Marking:</b>	CE 0722 Ex II 2 GD Ex db IIB Gb Ex tb IIIC Db IP66/67 (B..)	
<b>Certification:</b>	ATEX CESI 99 ATEX 034U	
	IECEX	IECEX CES 10.0002U

For IEC Ex and others certifications data can be downloaded at [www.elfit.com](http://www.elfit.com)

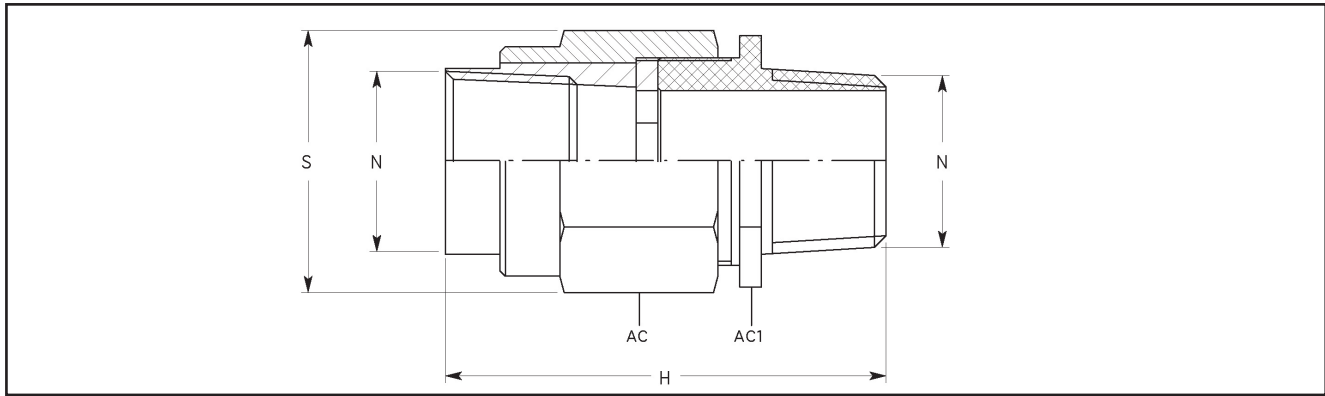
<b>Standards:</b>	CENELEC EN 60079-0: 2012+A11:2013, EN 60079-1: 2014, EN 60079-31: 2014 and EUROPEAN DIRECTIVE 2014/34/UE IEC60079-0: 2011, IEC60079-1: 2007-04, IEC60079-31: 2008 Directive RoHS 2002/95/CE
<b>Degree of protection:</b>	IP66/67

<b>Operating temperature:</b>			
Three pieces unions series	Materials	Gaskets	Ambient temperature
BMF...	Galvanised steel (G), Nickel-plated brass (B)	Silicone	-20°C +60°C
BMF...S	Stainless steel (S)	Silicone	-60°C +60°C

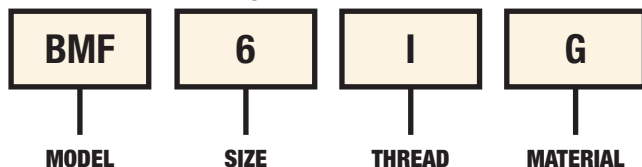
Certificates are available on [www.elfit.com](http://www.elfit.com)






**UNIONS SELECTION TABLE**

Code In galvanised steel	Thread N	Dimensions in mm				Weight Kg
		H	S	AC	AC1	
BMF1G	1/2" ISO7/1	60	35	30	27	0,150
BMF2G	3/4" ISO7/1	61	40	35	32	0,185
BMF3G	1" ISO7/1	71,5	48	42	40	0,300
BMF4G	1 1/4" ISO7/1	86	60	55	59	0,760
BMF5G	1 1/2" ISO7/1	86,5	75	70	67	1,000
BMF6G	2" ISO7/1	88	90	84	77	1,400
BMF7G	2 1/2" ISO7/1	107	117	108	99	2,350
BMF8G	3" ISO7/1	109	132	121	108	2,800
BMF10G	4" ISO7/1	116,5	152	145	135	4,160
BMF1NG	1/2" NPT	60	35	30	27	0,150
BMF2NG	3/4" NPT	61	40	35	32	0,185
BMF3NG	1" NPT	71,5	48	42	40	0,300
BMF4NG	1 1/4" NPT	86	60	55	59	0,760
BMF5NG	1 1/2" NPT	86,5	75	70	67	1,000
BMF6NG	2" NPT	88	90	84	77	1,400
BMF7NG	2 1/2" NPT	107	117	108	99	2,350
BMF8NG	3" NPT	109	132	121	108	2,800
BMF10NG	4" NPT	116,5	152	145	135	4,160
BMF1IG	M20x1,5	60	35	30	27	0,150
BMF2IG	M25x1,5	61	40	35	32	0,185
BMF3IG	M32x1,5	71,5	48	42	40	0,300
BMF4IG	M40x1,5	86	60	55	59	0,760
BMF5IG	M50x1,5	86,5	75	70	67	1,000
BMF6IG	M63x1,5	88	90	84	77	1,400
BMF7IG	M75x1,5	107	117	108	99	2,350
BMF8IG	M90x1,5	109	132	121	108	2,800
BMF10IG	M100x1,5	116,5	152	145	135	4,160

**Order code example**

**TECHNICAL NOTES:**

- The silicone O-ring for the IP protection for cylindrical threads (ISO metric) is supplied already assembled on the union
- Available also in stainless steel (example code **BMF1S**)
- Available also upon request in nickel-plated brass (example code **BMF1B**)
- It is possible supply mixed thread, of the same equivalence, adding code for female thread (sample code for fitting in galvanised steel Male 1"NPT - Female M32x1,5: **BMF3NIG**)

**BFF three pieces unions Fixed female / Turning female - IIB**

BFF series three pieces unions for IIB gas group enable an independent rotation and connection between pipes, enclosures or different equipment.



<b>Classification:</b> 2014/34/UE	Group II	Category 2GD
<b>Installation:</b> EN 60079.14	zone 1 - zone 2 (Gas)	zone 21 - zone 22 (Dust)
<b>Marking:</b>	CE 0722 Ex II 2 GD Ex db IIB Gb Ex ib IIIC Db IP66/67 (B..)	
<b>Certification:</b>	ATEX CESI 99 ATEX 034U	
	IECEX	IECEX CES 10.0002U

For IEC Ex and others certifications data can be downloaded at [www.elfit.com](http://www.elfit.com)

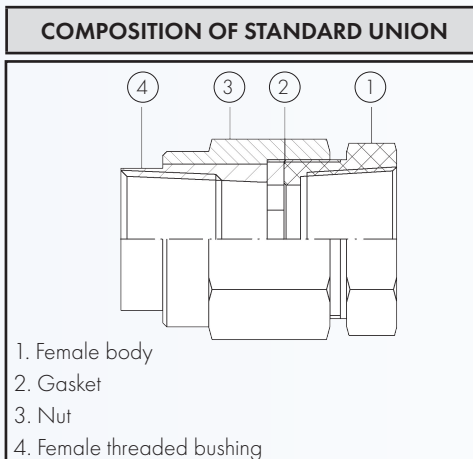
<b>Standards:</b>	CENELEC EN 60079-0: 2012+A11:2013, EN 60079-1: 2014, EN 60079-31: 2014 and EUROPEAN DIRECTIVE 2014/34/UE IEC60079-0: 2011, IEC60079-1: 2007-04, IEC60079-31: 2008 Directive RoHS 2002/95/CE
-------------------	--

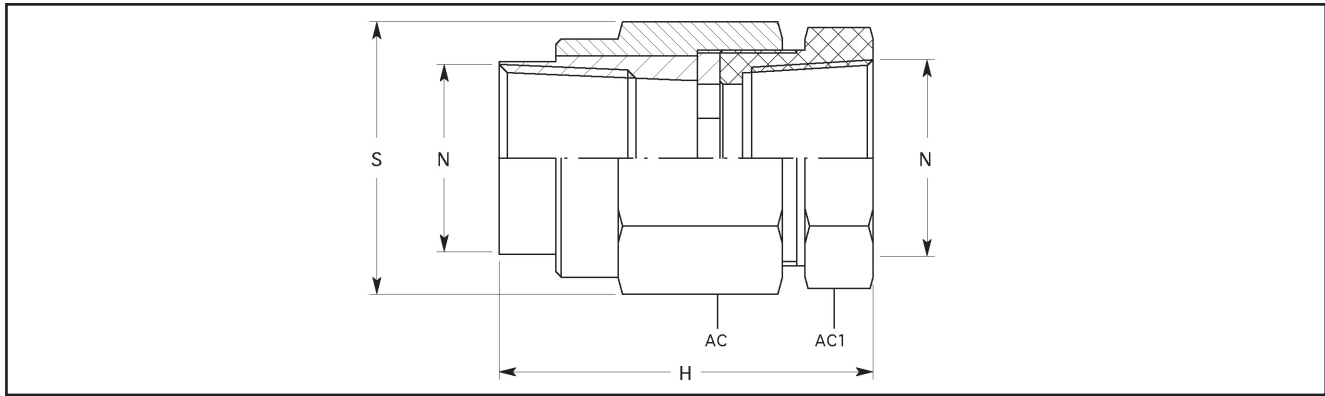
<b>Degree of protection:</b>	IP66/67
------------------------------	---------

**Operating temperature:**

Three pieces unions series	Materials	Gaskets	Ambient temperature
BFF...	Galvanised steel (G), Nickel-plated brass (B)	Silicone	-20°C +60°C
BFF...S	Stainless steel (S)	Silicone	-60°C +60°C

Certificates are available on [www.elfit.com](http://www.elfit.com)

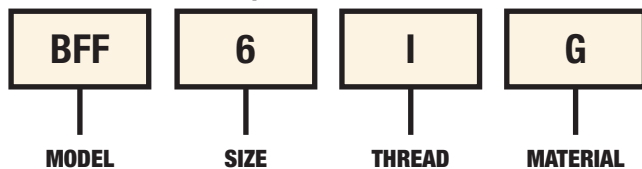




**UNIONS SELECTION TABLE**

Code In galvanised steel	Thread N	Dimensions in mm				Weight Kg
		H	S	AC	AC1	
BFF1G	1/2" ISO7/1	47	35	30	27	0,125
BFF2G	3/4" ISO7/1	47	40	35	32	0,150
BFF3G	1" ISO7/1	57	48	42	40	0,235
BFF4G	1 1/4" ISO7/1	63	60	55	59	0,640
BFF5G	1 1/2" ISO7/1	63	75	70	67	0,960
BFF6G	2" ISO7/1	64	90	84	77	1,220
BFF7G	2 1/2" ISO7/1	71	117	108	99	2,240
BFF8G	3" ISO7/1	71	132	121	108	2,600
BFF10G	4" ISO7/1	77	152	145	135	3,700
BFF1NG	1/2" NPT	57	35	30	27	0,125
BFF2NG	3/4" NPT	57	40	35	32	0,150
BFF3NG	1" NPT	67	48	42	40	0,235
BFF4NG	1 1/4" NPT	63	60	55	59	0,640
BFF5NG	1 1/2" NPT	63	75	70	67	0,960
BFF6NG	2" NPT	64	90	84	77	1,220
BFF7NG	2 1/2" NPT	71	117	108	99	2,240
BFF8NG	3" NPT	71	132	121	108	2,600
BFF10NG	4" NPT	77	152	145	135	3,700
BFF1IG	M20x1,5	47	35	30	27	0,125
BFF2IG	M25x1,5	47	40	35	32	0,150
BFF3IG	M32x1,5	52	48	42	40	0,235
BFF4IG	M40x1,5	63	60	55	59	0,640
BFF5IG	M50x1,5	63	75	70	67	0,960
BFF6IG	M63x1,5	64	90	84	77	1,220
BFF7IG	M75x1,5	71	117	108	99	2,240
BFF8IG	M90x1,5	71	132	121	108	2,600
BFF10IG	M100x1,5	77	152	145	135	3,700

**Order code example**



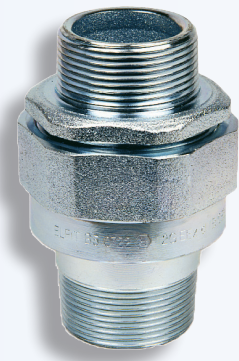
**TECHNICAL NOTES:**

- The silicone O-ring for the IP protection for cylindrical threads (ISO metric) is supplied already assembled on the union
- Available also in stainless steel (example code BFF1S)
- Available also upon request in nickel-plated brass (example code BFF1B)



**BMM three pieces unions Fixed male / Turning Male - IIB**

BMM series three pieces unions for IIB gas group enable an independent rotation and connection between pipes, enclosures or different equipment.



<b>Classification:</b> 2014/34/UE	Group II	Category 2GD
<b>Installation:</b> EN 60079-14	zone 1 - zone 2 (Gas)	zone 21 - zone 22 (Dust)
<b>Marking:</b>	CE 0722 Ex II 2 GD Ex db IIB Gb Ex ib IIIC Db IP66/67 (B..)	
<b>Certification:</b>	ATEX CESI 99 ATEX 034U	
	IECEX	IECEX CES 10.0002U

For IEC Ex and others certifications data can be downloaded at [www.elfit.com](http://www.elfit.com)

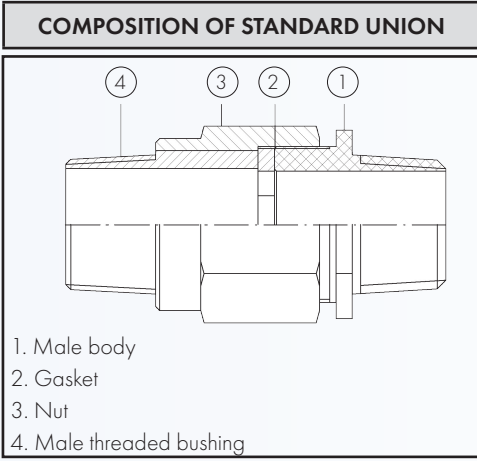
**Standards:** CENELEC EN 60079-0: 2012+A11:2013, EN 60079-1: 2014, EN 60079-31: 2014 and EUROPEAN DIRECTIVE 2014/34/UE  
IEC60079-0: 2011, IEC60079-1: 2007-04, IEC60079-31: 2008 Directive RoHS 2002/95/CE

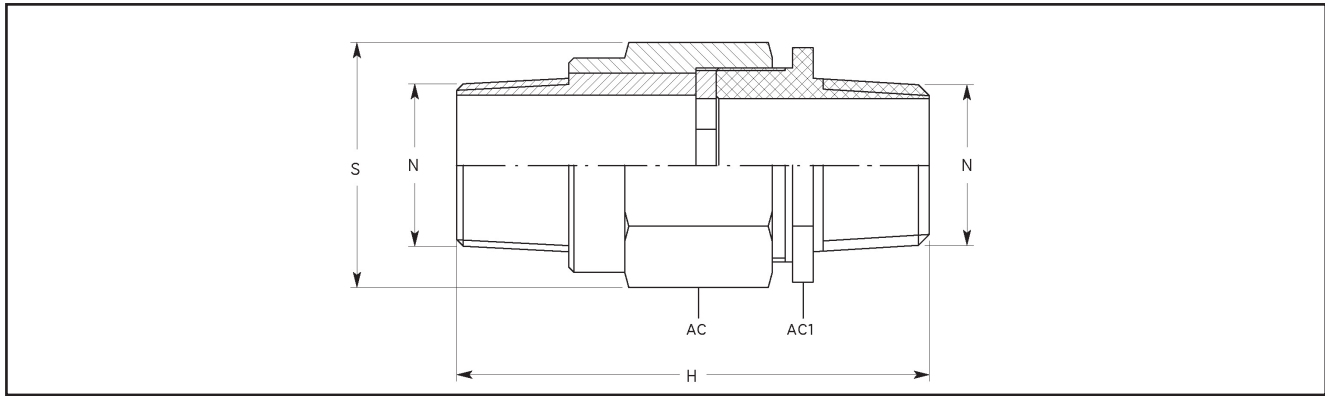
**Degree of protection:** IP66/67

**Operating temperature:**

Three pieces unions series	Materials	Gaskets	Ambient temperature
<b>BMM...</b>	Galvanised steel (G), Nickel-plated brass (B)	Silicone	-20°C +60°C
<b>BMM...S</b>	Stainless steel (S)	Silicone	-60°C +60°C

Certificates are available on [www.elfit.com](http://www.elfit.com)

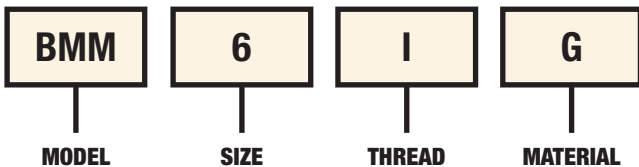




**UNIONS SELECTION TABLE**

Code In galvanised steel	Thread N	Dimensions in mm				Weight
		H	S	AC	AC1	Kg
BMM1G	1/2" ISO7/1	89	35	30	27	0,125
BMM2G	3/4" ISO7/1	87,5	40	35	32	0,150
BMM3G	1" ISO7/1	100,5	48	42	40	0,235
BMM4G	1 1/4" ISO7/1	111	60	55	59	0,640
BMM5G	1 1/2" ISO7/1	115	75	70	67	0,960
BMM6G	2" ISO7/1	113	90	84	77	1,220
BMM7G	2 1/2" ISO7/1	128	117	108	99	2,240
BMM8G	3" ISO7/1	130	132	121	108	2,600
BMM10G	4" ISO7/1	144	152	145	135	3,700
BMM1NG	1/2" NPT	89	35	30	27	0,125
BMM2NG	3/4" NPT	87,5	40	35	32	0,150
BMM3NG	1" NPT	100,5	48	42	40	0,235
BMM4NG	1 1/4" NPT	111	60	55	59	0,640
BMM5NG	1 1/2" NPT	115	75	70	67	0,960
BMM6NG	2" NPT	113	90	84	77	1,220
BMM7NG	2 1/2" NPT	128	117	108	99	2,240
BMM8NG	3" NPT	130	132	121	108	2,600
BMM10NG	4" NPT	144	152	145	135	3,700
BMM1IG	M20x1,5	89	35	30	27	0,125
BMM2IG	M25x1,5	87,5	40	35	32	0,150
BMM3IG	M32x1,5	100,5	48	42	40	0,235
BMM4IG	M40x1,5	111	60	55	59	0,640
BMM5IG	M50x1,5	115	75	70	67	0,960
BMM6IG	M63x1,5	113	90	84	77	1,220
BMM7IG	M75x1,5	128	117	108	99	2,240
BMM8IG	M90x1,5	130	132	121	108	2,600
BMM10IG	M100x1,5	144	152	145	135	3,700

**Order code example**



**TECHNICAL NOTES:**

- The silicone O-ring for the IP protection for cylindrical threads (ISO metric) is supplied already assembled on the union
- Available also in stainless steel (example code BMM1S)
- Available also upon request in nickel-plated brass (example code BMM1B)

RBMF series three pieces unions suitable for IIB gas group and extreme temperatures enable an independent rotation and connection between pipes, enclosures or different equipment.



<b>Classification:</b> 2014/34/UE	Group II	Category 2GD
<b>Installation:</b> EN 60079.14	zone 1 - zone 2 (Gas)	zone 21 - zone 22 (Dust)
<b>Marking:</b>	CE 0722 Ex II 2 GD Ex db IIB Gb Ex tb IIIC Db IP66/67 (RB..)	
<b>Certification:</b>	ATEX	CESI 99 ATEX 034U
	IECEX	IECEX CES 10.0002U

For IEC Ex and others certifications data can be downloaded at [www.elfit.com](http://www.elfit.com)

<b>Standards:</b>	CENELEC EN 60079-0: 2012+A11:2013, EN 60079-1: 2014, EN 60079-31: 2014 and EUROPEAN DIRECTIVE 2014/34/UE IEC60079-0: 2011, IEC60079-1: 2007-04, IEC60079-31: 2008 Directive RoHS 2002/95/CE
-------------------	--

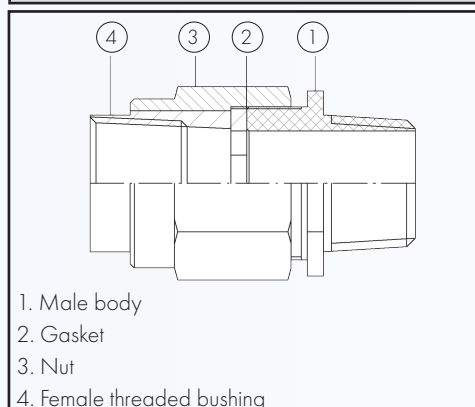
<b>Degree of protection:</b>	IP66/67
------------------------------	---------

**Operating temperature:**

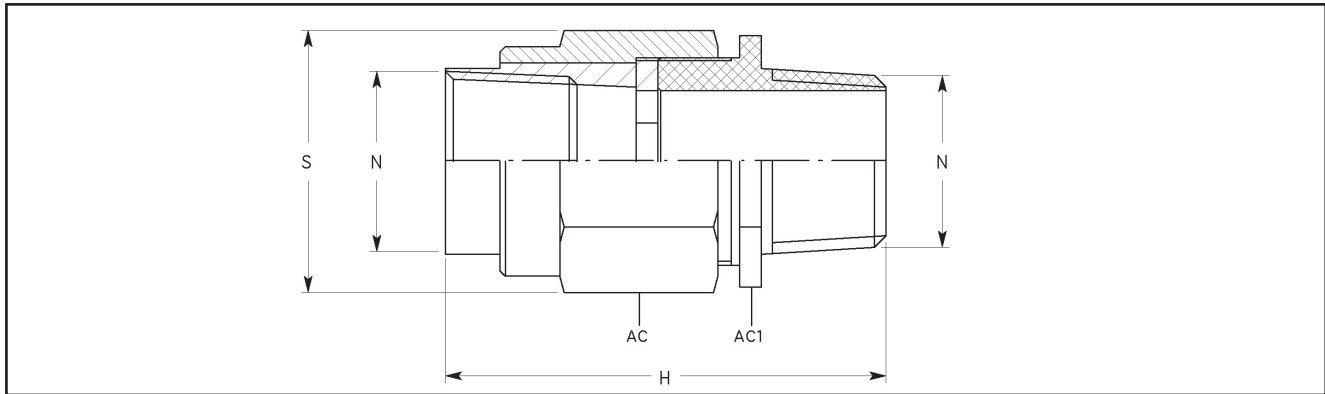
Three pieces unions series	Materials	Gaskets	Ambient temperature
RBMF...	Galvanised steel (G), Nickel-plated brass (B)	Silicone	-20°C +150°C
RBMF...S	Stainless steel (S)	Silicone	-60°C +150°C

Certificates are available on [www.elfit.com](http://www.elfit.com)

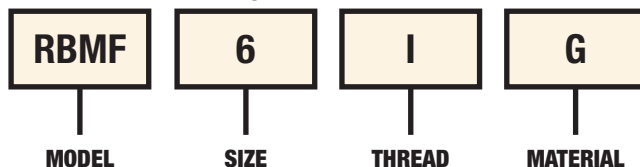
**COMPOSITION OF STANDARD UNION**






**UNIONS SELECTION TABLE**

Code In galvanised steel	Thread N	Dimensions in mm				Weight Kg
		H	S	AC	AC1	
RBMF1G	1/2" ISO7/1	71	35	30	27	0,150
RBMF2G	3/4" ISO7/1	72	40	35	32	0,185
RBMF3G	1" ISO7/1	82,5	48	42	40	0,300
RBMF4G	1 1/4" ISO7/1	86	60	55	59	0,760
RBMF5G	1 1/2" ISO7/1	86,5	75	70	67	1,000
RBMF6G	2" ISO7/1	88	90	84	77	1,400
RBMF7G	2 1/2" ISO7/1	107	117	108	99	2,350
RBMF8G	3" ISO7/1	109	132	121	108	2,800
RBMF10G	4" ISO7/1	116,5	152	145	135	4,160
RBMF1NG	1/2" NPT	71	35	30	27	0,150
RBMF2NG	3/4" NPT	72	40	35	32	0,185
RBMF3NG	1" NPT	82,5	48	42	40	0,300
RBMF4NG	1 1/4" NPT	86	60	55	59	0,760
RBMF5NG	1 1/2" NPT	86,5	75	70	67	1,000
RBMF6NG	2" NPT	88	90	84	77	1,400
RBMF7NG	2 1/2" NPT	107	117	108	99	2,350
RBMF8NG	3" NPT	109	132	121	108	2,800
RBMF10NG	4" NPT	116,5	152	145	135	4,160
RBMF1IG	M20x1,5	71	35	30	27	0,150
RBMF2IG	M25x1,5	72	40	35	32	0,185
RBMF3IG	M32x1,5	82,5	48	42	40	0,300
RBMF4IG	M40x1,5	86	60	55	59	0,760
RBMF5IG	M50x1,5	86,5	75	70	67	1,000
RBMF6IG	M63x1,5	88	90	84	77	1,400
RBMF7IG	M75x1,5	107	117	108	99	2,350
RBMF8IG	M90x1,5	109	132	121	108	2,800
RBMF10IG	M100x1,5	116,5	152	145	135	4,160

**Order code example**

**TECHNICAL NOTES:**

- The silicone O-ring for the IP protection for cylindrical threads (ISO metric) is supplied already assembled on the union
- Available also in stainless steel (example code RBMF1**S**)
- Available also in nickel-plated brass (example code RBMF1**B**)
- It is possible supply mixed thread, of the same equivalence (sample code for fitting in galvanised steel Male 1"NPT - Female M32x1,5: RBMF3NG)

RBFF series three pieces unions suitable for IIB gas group and extreme temperatures enable an independent rotation and connection between pipes, enclosures or different instruments.



<b>Classification:</b> 2014/34/UE	Group II	Category 2GD
<b>Installation:</b> EN 60079.14	zone 1 - zone 2 (Gas)	zone 21 - zone 22 (Dust)
<b>Marking:</b>	CE 0722 Ex II 2 GD Ex db IIB Gb Ex ib IIIC Db IP66/67 (RB..)	
<b>Certification:</b>	ATEX CESI 99 ATEX 034U	
	IECEX	IECEX CES 10.0002U

For IEC Ex and others certifications data can be downloaded at [www.elfit.com](http://www.elfit.com)

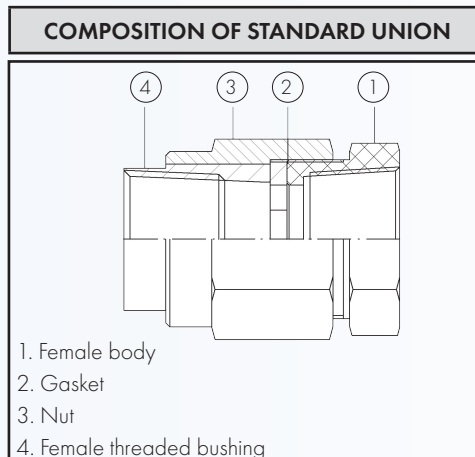
<b>Standards:</b>	CENELEC EN 60079-0: 2012+A11:2013, EN 60079-1: 2014, EN 60079-31: 2014 and EUROPEAN DIRECTIVE 2014/34/UE IEC60079-0: 2011, IEC60079-1: 2007-04, IEC60079-31: 2008 Directive RoHS 2002/95/CE
-------------------	--

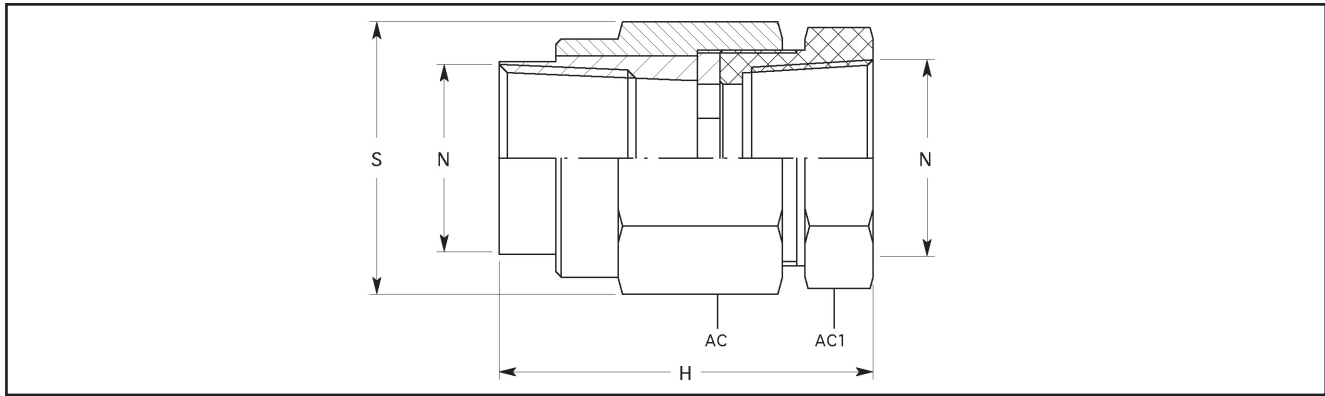
<b>Degree of protection:</b>	IP66/67
------------------------------	---------

**Operating temperature:**

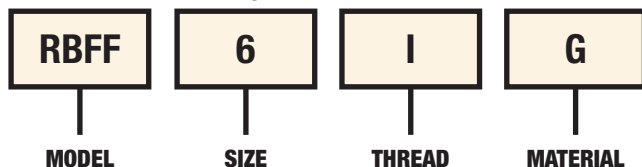
Three pieces unions series	Materials	Gaskets	Ambient temperature
RBFF...	Galvanised steel (G), Nickel-plated brass (B)	Silicone	-20°C +150°C
RBFF...S	Stainless steel (S)	Silicone	-60°C +150°C

Certificates are available on [www.elfit.com](http://www.elfit.com)




**UNIONS SELECTION TABLE**

Code In galvanised steel	Thread N	Dimensions in mm				Weight Kg
		H	S	AC	AC1	
RBFF1G	1/2" ISO7/1	57	35	30	27	0,125
RBFF2G	3/4" ISO7/1	57	40	35	32	0,150
RBFF3G	1" ISO7/1	67	48	42	40	0,235
RBFF4G	1 1/4" ISO7/1	63	60	55	59	0,640
RBFF5G	1 1/2" ISO7/1	63	75	70	67	0,960
RBFF6G	2" ISO7/1	64	90	84	77	1,220
RBFF7G	2 1/2" ISO7/1	71	117	108	99	2,240
RBFF8G	3" ISO7/1	71	132	121	108	2,600
RBFF10G	4" ISO7/1	77	152	145	135	3,700
RBFF1NG	1/2" NPT	57	35	30	27	0,125
RBFF2NG	3/4" NPT	57	40	35	32	0,150
RBFF3NG	1" NPT	67	48	42	40	0,235
RBFF4NG	1 1/4" NPT	63	60	55	59	0,640
RBFF5NG	1 1/2" NPT	63	75	70	67	0,960
RBFF6NG	2" NPT	64	90	84	77	1,220
RBFF7NG	2 1/2" NPT	71	117	108	99	2,240
RBFF8NG	3" NPT	71	132	121	108	2,600
RBFF10NG	4" NPT	77	152	145	135	3,700
RBFF1IG	M20x1,5	57	35	30	27	0,125
RBFF2IG	M25x1,5	57	40	35	32	0,150
RBFF3IG	M32x1,5	67	48	42	40	0,235
RBFF4IG	M40x1,5	63	60	55	59	0,640
RBFF5IG	M50x1,5	63	75	70	67	0,960
RBFF6IG	M63x1,5	64	90	84	77	1,220
RBFF7IG	M75x1,5	71	117	108	99	2,240
RBFF8IG	M90x1,5	71	132	121	108	2,600
RBFF10IG	M100x1,5	77	152	145	135	3,700

**Order code example**

**TECHNICAL NOTES:**

- The silicone O-ring for the IP protection for cylindrical threads (ISO metric) is supplied already assembled on the union
- Available also in stainless steel (example code RBFF1S)
- Available also in nickel-plated brass (example code RBFF1B)



RBMM series three pieces unions suitable for IIB gas group and extreme temperatures enable an independent rotation and connection between pipes, enclosures or different instruments.



<b>Classification:</b> 2014/34/UE	Group II	Category 2GD
<b>Installation:</b> EN 60079.14	zone 1 - zone 2 (Gas)	zone 21 - zone 22 (Dust)
<b>Marking:</b>	CE 0722 Ex II 2 GD Ex db IIB Gb Ex tb IIIC Db IP66/67 (RB..)	
<b>Certification:</b>	ATEX CESI 99 ATEX 034U	
	IECEX	IECEX CES 10.0002U

For IEC Ex and others certifications data can be downloaded at [www.elfit.com](http://www.elfit.com)

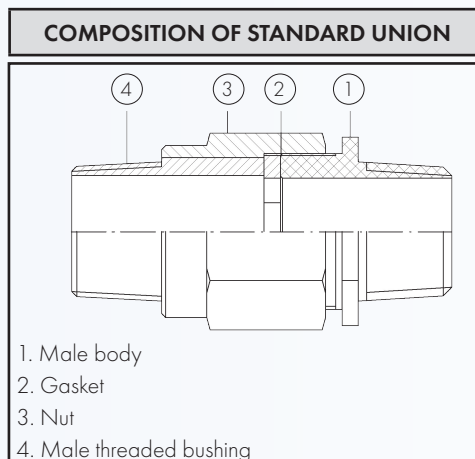
<b>Standards:</b>	CENELEC EN 60079-0: 2012+A11:2013, EN 60079-1: 2014, EN 60079-31: 2014 and EUROPEAN DIRECTIVE 2014/34/UE IEC60079-0: 2011, IEC60079-1: 2007-04, IEC60079-31: 2008 Directive RoHS 2002/95/CE
-------------------	--

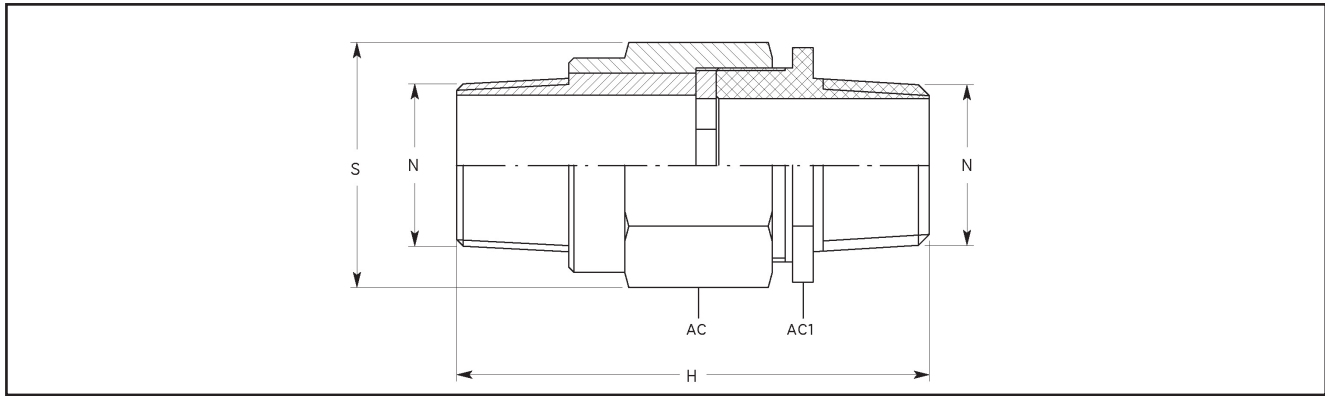
<b>Degree of protection:</b>	IP66/67
------------------------------	---------

**Operating temperature:**

Three pieces unions series	Materials	Gaskets	Ambient temperature
RBMM...	Galvanised steel (G), Nickel-plated brass (B)	Silicone	-20°C +150°C
RBMM...S	Stainless steel (S)	Silicone	-60°C +150°C

Certificates are available on [www.elfit.com](http://www.elfit.com)

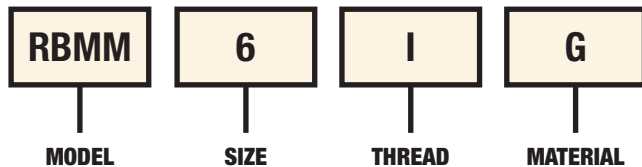




**UNIONS SELECTION TABLE**

Code In galvanised steel	Thread N	Dimensions in mm				Weight Kg
		H	S	AC	AC1	
RBMM1G	1/2" ISO7/1	99	35	30	27	0,125
RBMM2G	3/4" ISO7/1	97,5	40	35	32	0,150
RBMM3G	1" ISO7/1	110,5	48	42	40	0,235
RBMM4G	1 1/4" ISO7/1	121	60	55	59	0,640
RBMM5G	1 1/2" ISO7/1	125	75	70	67	0,960
RBMM6G	2" ISO7/1	123	90	84	77	1,220
RBMM7G	2 1/2" ISO7/1	143	117	108	99	2,240
RBMM8G	3" ISO7/1	145	132	121	108	2,600
RBMM10G	4" ISO7/1	144	152	145	135	3,700
RBMM1NG	1/2" NPT	99	35	30	27	0,125
RBMM2NG	3/4" NPT	97,5	40	35	32	0,150
RBMM3NG	1" NPT	110,5	48	42	40	0,235
RBMM4NG	1 1/4" NPT	121	60	55	59	0,640
RBMM5NG	1 1/2" NPT	125	75	70	67	0,960
RBMM6NG	2" NPT	123	90	84	77	1,220
RBMM7NG	2 1/2" NPT	143	117	108	99	2,240
RBMM8NG	3" NPT	145	132	121	108	2,600
RBMM10NG	4" NPT	144	152	145	135	3,700
RBMM1IG	M20x1,5	99	35	30	27	0,125
RBMM2IG	M25x1,5	97,5	40	35	32	0,150
RBMM3IG	M32x1,5	110,5	48	42	40	0,235
RBMM4IG	M40x1,5	121	60	55	59	0,640
RBMM5IG	M50x1,5	125	75	70	67	0,960
RBMM6IG	M63x1,5	123	90	84	77	1,220
RBMM7IG	M75x1,5	143	117	108	99	2,240
RBMM8IG	M90x1,5	145	132	121	108	2,600
RBMM10IG	M100x1,5	144	152	145	135	3,700

**Order code example**



**TECHNICAL NOTES:**

- The silicone O-ring for the IP protection for cylindrical threads (ISO metric) is supplied already assembled on the union
- Available also in stainless steel (example code RBMM1S)
- Available also in nickel-plated brass (example code RBMM1B)

**RMF three pieces unions Fixed male/Turning female - IIC**

RMF series three pieces unions for IIC gas group enable an independent rotation and connection between pipes, enclosures or different instruments.



<b>Classification:</b> 2014/34/UE	Group II	Category 2GD
<b>Installation:</b> EN 60079.14	zone 1 - zone 2 (Gas)	zone 21 - zone 22 (Dust)
<b>Marking:</b>	CE 0722 Ex II 2 GD Ex db IIC Gb Ex tb IIIC Db IP66/67 (R..)	
<b>Certification:</b>	ATEX CESI 99 ATEX 034U	
	IECEX	IECEX CES 10.0002U

For IEC Ex and others certifications data can be downloaded at [www.elfit.com](http://www.elfit.com)

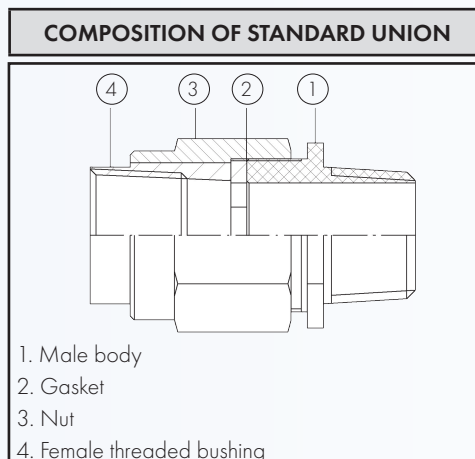
<b>Standards:</b>	CENELEC EN 60079-0: 2012+A11:2013, EN 60079-1: 2014, EN 60079-31: 2014 and EUROPEAN DIRECTIVE 2014/34/UE IEC60079-0: 2011, IEC60079-1: 2007-04, IEC60079-31: 2008 Directive RoHS 2002/95/CE
-------------------	--

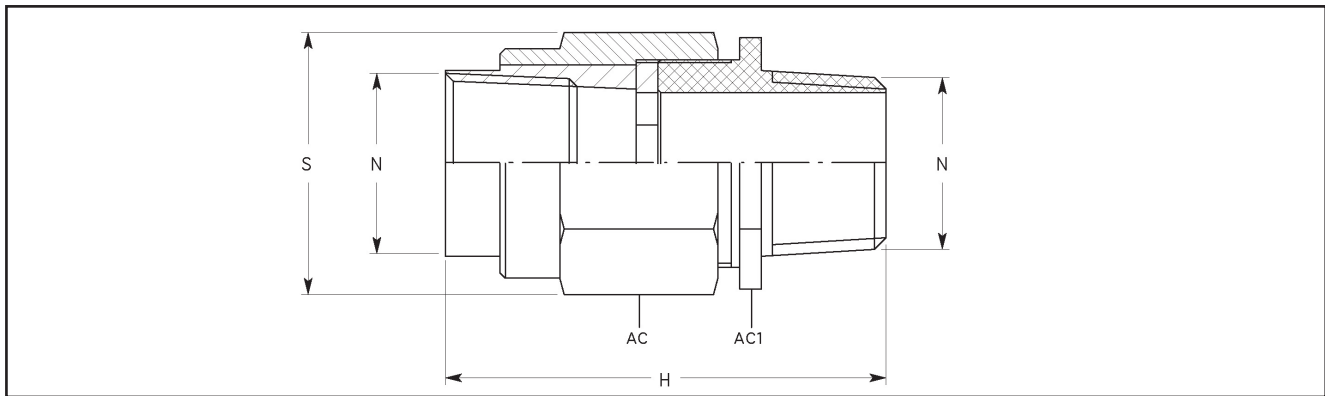
<b>Degree of protection:</b>	IP66/67
------------------------------	---------

**Operating temperature:**

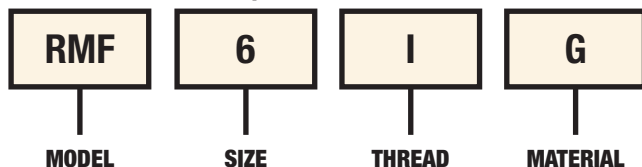
Three pieces unions series	Materials	Gaskets	Ambient temperature
RMF...	Galvanised steel (G), Nickel-plated brass (B)	Silicone	-20°C +60°C
RMF...S	Stainless steel (S)	Silicone	-60°C +60°C

Certificates are available on [www.elfit.com](http://www.elfit.com)




**UNIONS SELECTION TABLE**

Code In galvanised steel	Thread N	Dimensions in mm				Weight Kg
		H	S	AC	AC1	
RMF1G	1/2" ISO7/1	71	35	30	27	0,200
RMF2G	3/4" ISO7/1	71	40	35	32	0,230
RMF3G	1" ISO7/1	82	48	42	40	0,380
RMF4G	1 1/4" ISO7/1	87	60	55	59	0,940
RMF5G	1 1/2" ISO7/1	87	75	70	67	1,125
RMF6G	2" ISO7/1	87	90	84	77	1,540
RMF7G	2 1/2" ISO7/1	98	117	108	99	3,125
RMF8G	3" ISO7/1	98	132	121	108	3,990
RMF10G	4" ISO7/1	112	152	145	135	4,160
RMF1NG	1/2" NPT	71	35	30	27	0,200
RMF2NG	3/4" NPT	71	40	35	32	0,230
RMF3NG	1" NPT	82	48	42	40	0,380
RMF4NG	1 1/4" NPT	87	60	55	59	0,940
RMF5NG	1 1/2" NPT	87	75	70	67	1,125
RMF6NG	2" NPT	87	90	84	77	1,540
RMF7NG	2 1/2" NPT	98	117	108	99	3,125
RMF8NG	3" NPT	98	132	121	108	3,990
RMF10NG	4" NPT	112	152	145	135	4,160
RMF1IG	M20x1,5	71	35	30	27	0,200
RMF2IG	M25x1,5	71	40	35	32	0,230
RMF3IG	M32x1,5	82	48	42	40	0,380
RMF4IG	M40x1,5	87	60	55	59	0,940
RMF5IG	M50x1,5	87	75	70	67	1,125
RMF6IG	M63x1,5	87	90	84	77	1,540
RMF7IG	M75x1,5	98	117	108	99	3,125
RMF8IG	M90x1,5	98	132	121	108	3,990
RMF10IG	M100x1,5	112	152	145	135	4,160

**Order code example**

**TECHNICAL NOTES:**

- The silicone O-ring for the IP protection for cylindrical threads (ISO metric) is supplied already assembled on the union
- Available also in stainless steel (example code **RMF1S**)
- Available also in nickel-plated brass (example code **RMF1B**)
- It is possible supply mixed thread, of the same equivalence (sample code for fitting in galvanised steel Male 1"NPT - Female M32x1,5: **RMF3NIG**)



**RFF three pieces unions Fixed female/Turning female - IIC**

RFF series three pieces unions for IIC gas group enable an independent rotation and connection between pipes, enclosures or different equipment.



<b>Classification:</b> 2014/34/UE	Group II	Category 2GD
<b>Installation:</b> EN 60079.14	zone 1 - zone 2 (Gas)	zone 21 - zone 22 (Dust)
<b>Marking:</b>	CE 0722 Ex II 2 GD Ex db IIC Gb Ex tb IIIC Db IP66/67 (R..)	
<b>Certification:</b>	ATEX CESI 99 ATEX 034U	
	IECEX	IECEX CES 10.0002U

For IEC Ex and others certifications data can be downloaded at [www.elfit.com](http://www.elfit.com)

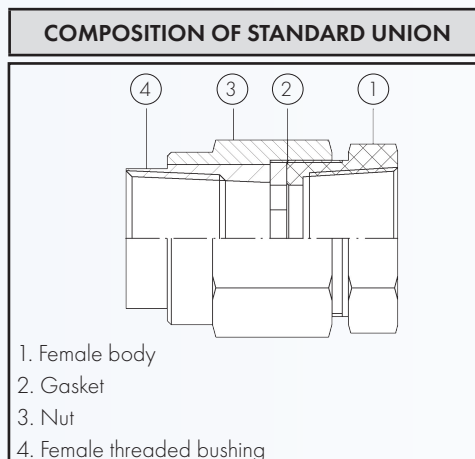
<b>Standards:</b>	CENELEC EN 60079-0: 2012+A11:2013, EN 60079-1: 2014, EN 60079-31: 2014 and EUROPEAN DIRECTIVE 2014/34/UE IEC60079-0: 2011, IEC60079-1: 2007-04, IEC60079-31: 2008 Directive RoHS 2002/95/CE
-------------------	--

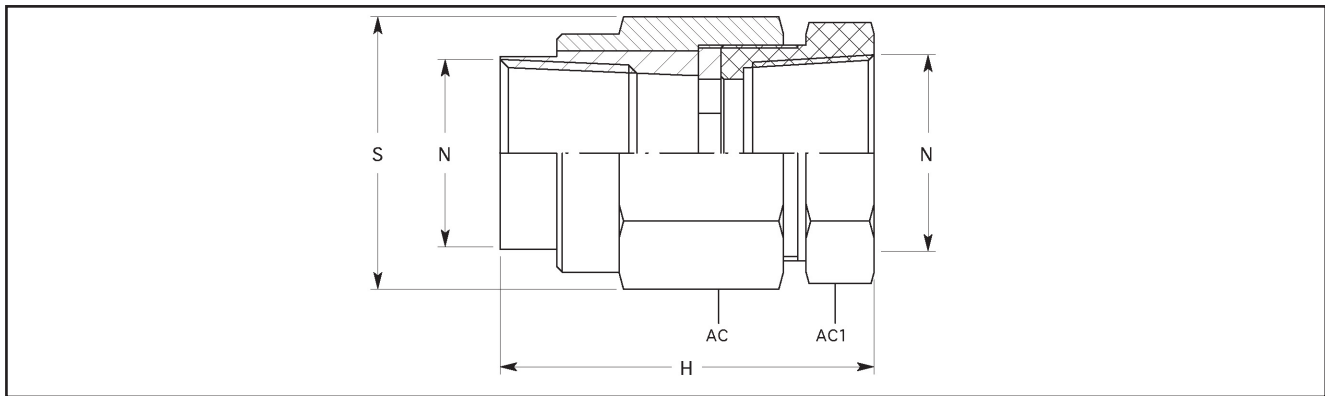
<b>Degree of protection:</b>	IP66/67
------------------------------	---------

**Operating temperature:**

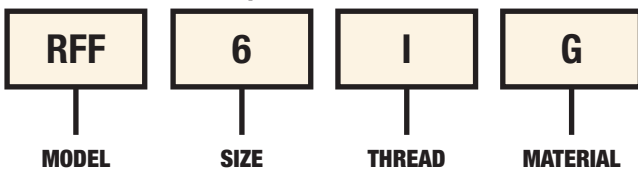
Three pieces unions series	Materials	Gaskets	Ambient temperature
RFF...	Galvanised steel (G), Nickel-plated brass (B)	Silicone	-20°C +60°C
RFF...S	Stainless steel (S)	Silicone	-60°C +60°C

Certificates are available on [www.elfit.com](http://www.elfit.com)




**UNIONS SELECTION TABLE**

Code In galvanised steel	Thread N	Dimensions in mm				Weight Kg
		H	S	AC	AC1	
RFF1G	1/2" ISO7/1	58	35	30	27	0,170
RFF2G	3/4" ISO7/1	58	40	35	32	0,200
RFF3G	1" ISO7/1	68	48	42	40	0,315
RFF4G	1 1/4" ISO7/1	63	60	55	59	0,820
RFF5G	1 1/2" ISO7/1	66	75	70	67	1,020
RFF6G	2" ISO7/1	66	90	84	77	1,390
RFF7G	2 1/2" ISO7/1	71	117	108	99	2,520
RFF8G	3" ISO7/1	71	132	121	108	2,900
RFF10G	4" ISO7/1	86	152	145	135	3,700
RFF1NG	1/2" NPT	58	35	30	27	0,170
RFF2NG	3/4" NPT	58	40	35	32	0,200
RFF3NG	1" NPT	68	48	42	40	0,315
RFF4NG	1 1/4" NPT	63	60	55	59	0,820
RFF5NG	1 1/2" NPT	66	75	70	67	1,020
RFF6NG	2" NPT	66	90	84	77	1,390
RFF7NG	2 1/2" NPT	71	117	108	99	2,520
RFF8NG	3" NPT	71	132	121	108	2,900
RFF10NG	4" NPT	86	152	145	135	3,700
RFF1IG	M20x1,5	58	35	30	27	0,170
RFF2IG	M25x1,5	58	40	35	32	0,200
RFF3IG	M32x1,5	68	48	42	40	0,315
RFF4IG	M40x1,5	63	60	55	59	0,820
RFF5IG	M50x1,5	66	75	70	67	1,020
RFF6IG	M63x1,5	66	90	84	77	1,390
RFF7IG	M75x1,5	71	117	108	99	2,520
RFF8IG	M90x1,5	71	132	121	108	2,900
RFF10IG	M100x1,5	86	152	145	135	3,700

**Order code example**

**TECHNICAL NOTES:**

- The silicone O-ring for the IP protection for cylindrical threads (ISO metric) is supplied already assembled on the union
- Available also in stainless steel (example code RFF1S)
- Available also in nickel-plated brass (example code RFF1B)

**RMM three pieces unions Fixed male/Turning male - IIC**

RMM series three pieces unions for IIC gas group enable an independent rotation and connection between pipes, enclosures or different equipment.



<b>Classification:</b> 2014/34/UE	Group II	Category 2GD
<b>Installation:</b> EN 60079.14	zone 1 - zone 2 (Gas)	zone 21 - zone 22 (Dust)
<b>Marking:</b>	CE 0722 Ex II 2 GD Ex db IIC Gb Ex tb IIIC Db IP66/67 (R..)	
<b>Certification:</b>	ATEX CESI 99 ATEX 034U	
	IECEX	IECEX CES 10.0002U

For IEC Ex and others certifications data can be downloaded at [www.elfit.com](http://www.elfit.com)

<b>Standards:</b>	CENELEC EN 60079-0: 2012+A11:2013, EN 60079-1: 2014, EN 60079-31: 2014 and EUROPEAN DIRECTIVE 2014/34/UE IEC60079-0: 2011, IEC60079-1: 2007-04, IEC60079-31: 2008 Directive RoHS 2002/95/CE
-------------------	--

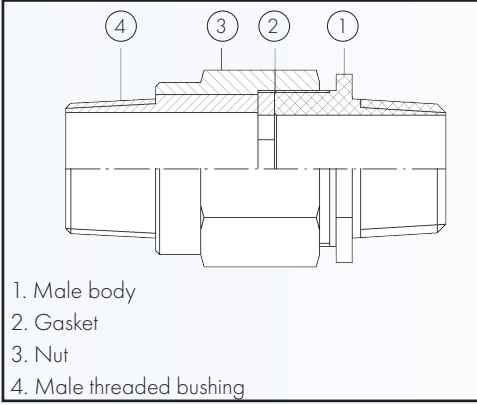
<b>Degree of protection:</b>	IP66/67
------------------------------	---------

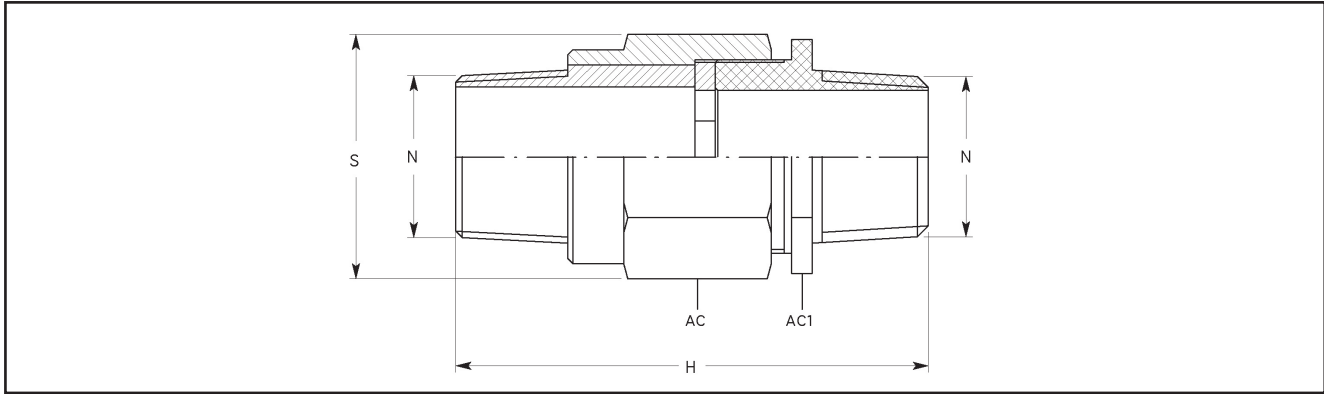
**Operating temperature:**

Three pieces unions series	Materials	Gaskets	Ambient temperature
RMM...	Galvanised steel (G), Nickel-plated brass (B)	Silicone	-20°C +60°C
RMM...S	Stainless steel (S)	Silicone	-60°C +60°C

Certificates are available on [www.elfit.com](http://www.elfit.com)

**COMPOSITION OF STANDARD UNION**

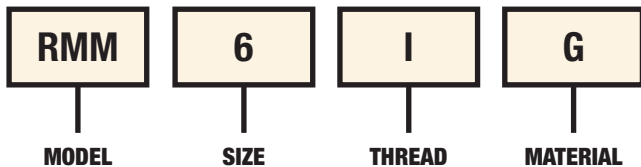




**UNIONS SELECTION TABLE**

Code In galvanised steel	Thread N	Dimensions in mm				Weight
		H	S	AC	AC1	Kg
RMM1G	1/2" ISO7/1	97	35	30	27	0,220
RMM2G	3/4" ISO7/1	97	40	35	32	0,290
RMM3G	1" ISO7/1	110	48	42	40	0,425
RMM4G	1 1/4" ISO7/1	125	60	55	59	1,200
RMM5G	1 1/2" ISO7/1	125	75	70	67	1,500
RMM6G	2" ISO7/1	125	90	84	77	1,900
RMM7G	2 1/2" ISO7/1	142	117	108	99	4,000
RMM8G	3" ISO7/1	142	132	121	108	4,000
RMM10G	4" ISO7/1	150	152	145	135	5,160
RMM1NG	1/2" NPT	97	35	30	27	0,220
RMM2NG	3/4" NPT	97	40	35	32	0,290
RMM3NG	1" NPT	110	48	42	40	0,425
RMM4NG	1 1/4" NPT	125	60	55	59	1,200
RMM5NG	1 1/2" NPT	125	75	70	67	1,500
RMM6NG	2" NPT	125	90	84	77	1,900
RMM7NG	2 1/2" NPT	142	117	108	99	4,000
RMM8NG	3" NPT	142	132	121	108	4,000
RMM10NG	4" NPT	150	152	145	135	5,160
RMM1IG	M20x1,5	97	35	30	27	0,220
RMM2IG	M25x1,5	97	40	35	32	0,290
RMM3IG	M32x1,5	110	48	42	40	0,425
RMM4IG	M40x1,5	125	60	55	59	1,200
RMM5IG	M50x1,5	125	75	70	67	1,500
RMM6IG	M63x1,5	125	90	84	77	1,900
RMM7IG	M75x1,5	142	117	108	99	4,000
RMM8IG	M90x1,5	142	132	121	108	4,000
RMM10IG	M100x1,5	150	152	145	135	5,160

Order code example



TECHNICAL NOTES:

- The silicone O-ring for the IP protection for cylindrical threads (ISO metric) is supplied already assembled on the union
- Available also in stainless steel (example code RMM1S)
- Available also in nickel-plated brass (example code RMM1B)



Reducers and adaptors are used to join instruments, enclosures, pipes and hubs of different diameter and threads.



<b>Classification:</b> 2014/34/UE	Group II	Category 2GD
<b>Installation:</b> EN 60079.14	zone 1 - zone 2 (Gas)	zone 21 - zone 22 (Dust)
<b>Marking:</b>	CE 0722 Ex II 2 GD Ex db IIC Gb Ex tb IIIC Db IP66/67	
	CE 0722 Ex II 2 GD Ex eb IIC Gb Ex tb IIIC Db IP66/67	
<b>Certification</b>	ATEX CESI 02 ATEX 049X	
	IECEX	IECEX CES 10.0001X

For IEC Ex and others certifications data can be downloaded at [www.elfit.com](http://www.elfit.com)

<b>Standards:</b>	CENELEC EN 60079-0: 2012+A11: 2013, EN 60079-1: 2014, EN 60079-7: 2015, EN 60079-31: 2014 and EUROPEAN DIRECTIVE 2014/34/UE IEC60079-0: 2011, IEC60079-1: 2007-04, IEC60079-7: 2006-07, IEC60079-31: 2008 Directive RoHS 2002/95/CE
<b>Degree of protection:</b>	IP66/67

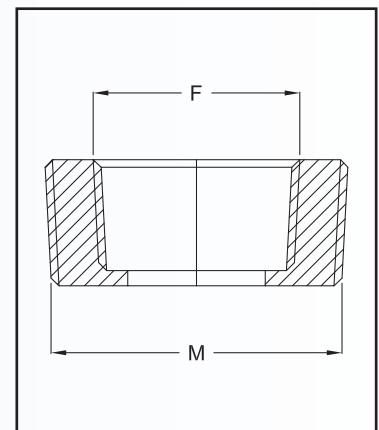
**Operating temperature:**

Adaptors	Material	Ambient temperature
RE...	Galvanised steel (G)	-20°C +80°C
RE...	Nickel-plated brass (B), Aluminium alloy (A)	-40°C +150°C
RE...	Stainless steel (S)	-60°C +150°C

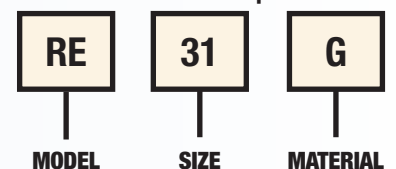
Certificates are available on [www.elfit.com](http://www.elfit.com)

### SELECTION TABLE OF STANDARD ADAPTORS

Thread ISO7/1	Ø FEMALE F									
	1/4"	3/8"	1/2"	3/4"	1"	1 ¼"	1 ½"	2"	2 ½"	
Ø MALE M	3/8"	RE3814								
	1/2"	RE114	RE138							
	3/4"	RE214	RE238	RE21						
	1"	RE314	RE338	RE31	RE32					
	1 ¼"	RE414	RE438	RE41	RE42	RE43				
	1 ½"	RE514	RE538	RE51	RE52	RE53	RE54			
	2"	RE614	RE638	RE61	RE62	RE63	RE64	RE65		
	2 ½"			RE71	RE72	RE73	RE74	RE75	RE76	
	3"			RE81	RE82	RE83	RE84	RE85	RE86	RE87



Order code example of standard adaptors

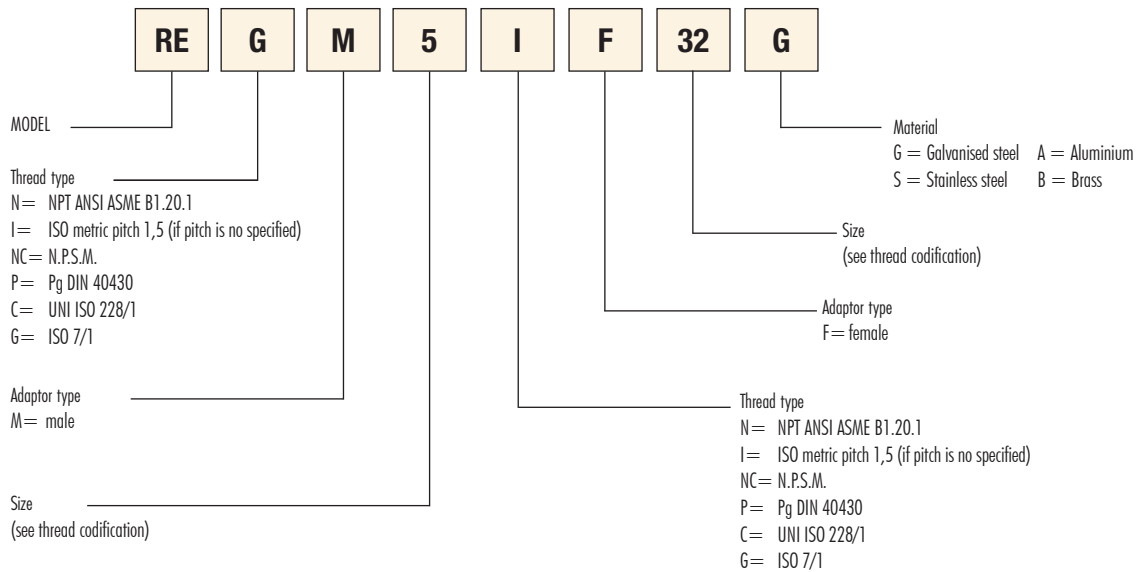


**TECHNICAL NOTES:**

- Available with other threads (example code RE31NG)
- Available in different materials (example code RE31A)
- Size over 3" upon request

**SPECIAL ADAPTORS (MIXED THREADS)**
**Order code example**

(Adaptor type RE, male 1 1/2" Gk, female M32x1,5, galvanised steel)


**THREAD CODIFICATION**
**NPT, N.P.S.M., UNI ISO 228/1, ISO7/1**

02	01	1	2	3	4	5	6	7	8	9	10	12	14
1/4"	3/8"	1/2"	3/4"	1"	1 1/4"	1 1/2"	2	2 1/2"	3"	3 1/2"	4"	5"	6"

**ISO Metric**

12	16	20	25	32	40	50	63	75	90	100	63X2	75X2	90X2
M12x1,5	M16x1,5	M20x1,5	M25x1,5	M32x1,5	M40x1,5	M50x1,5	M63x1,5	M75x1,5	M90x1,5	M100x1,5	M63x2	M75x2	M90x2

**Pg DIN 40430**

2	3	4	5	6	7	8	9	10
PG9	PG11	PG13,5	PG16	PG21	PG29	PG36	PG42	PG48

# Adaptors **REB** female - male

Reducers and adaptors are used to join instruments, enclosures, pipes and hubs of different diameter and threads.



<b>Classification:</b> 2014/34/UE	Group II	Category 2GD
<b>Installation:</b> EN 60079.14	zone 1 - zone 2 (Gas)	zone 21 - zone 22 (Dust)
<b>Marking:</b>	CE 0722 Ex II 2 GD Ex db IIC Gb Ex tb IIIC Db IP66/67	
	CE 0722 Ex II 2 GD Ex eb IIC Gb Ex tb IIIC Db IP66/67	
<b>Certification</b>	ATEX CESI 02 ATEX 049X	
	IECEX	IECEX CES 10.0001X

For IEC Ex and others certifications data can be downloaded at [www.elfit.com](http://www.elfit.com)

<b>Standards:</b>	CENELEC EN 60079-0: 2012+A11: 2013, EN 60079-1: 2014, EN 60079-7: 2015, EN 60079-31: 2014 and EUROPEAN DIRECTIVE 2014/34/UE IEC60079-0: 2011, IEC60079-1: 2007-04, IEC60079-7: 2006-07, IEC60079-31: 2008 Directive RoHS 2002/95/CE
-------------------	--

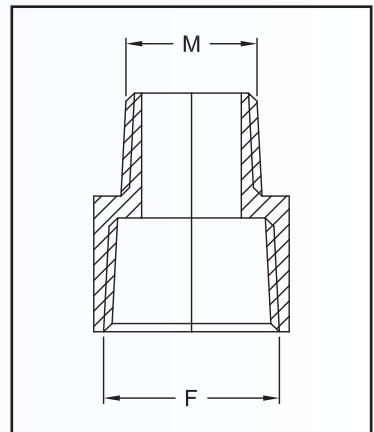
<b>Degree of protection:</b>	IP66/67
------------------------------	---------

**Operating temperature:**

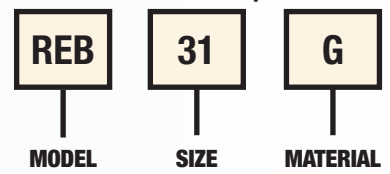
Adaptors	Material	Ambient temperature
REB...	Galvanised steel ( <b>G</b> )	-20°C +80°C
REB...	Nickel-plated brass ( <b>B</b> ), Aluminium alloy ( <b>A</b> )	-40°C +150°C
REB...	Stainless steel ( <b>S</b> )	-60°C +150°C

Certificates are available on [www.elfit.com](http://www.elfit.com)

SELECTION TABLE OF STANDARD ADAPTORS										
Thread ISO7/1	Ø MALE M									
	1/4"	3/8"	1/2"	3/4"	1"	1 1/4"	1 1/2"	2"	2 1/2"	
Ø FEMALE F	3/8"	REB3814								
	1/2"	REB114	REB138							
	3/4"	REB214	REB238	REB21						
	1"	REB314	REB338	REB31	REB32					
	1 1/4"	REB414	REB438	REB41	REB42	REB43				
	1 1/2"	REB514	REB538	REB51	REB52	REB53	REB54			
	2"	REB614	REB638	REB61	REB62	REB63	REB64	REB65		
	2 1/2"			REB71	REB72	REB73	REB74	REB75	REB76	
	3"			REB81	REB82	REB83	REB84	REB85	REB86	REB87



Order code example of standard adaptors

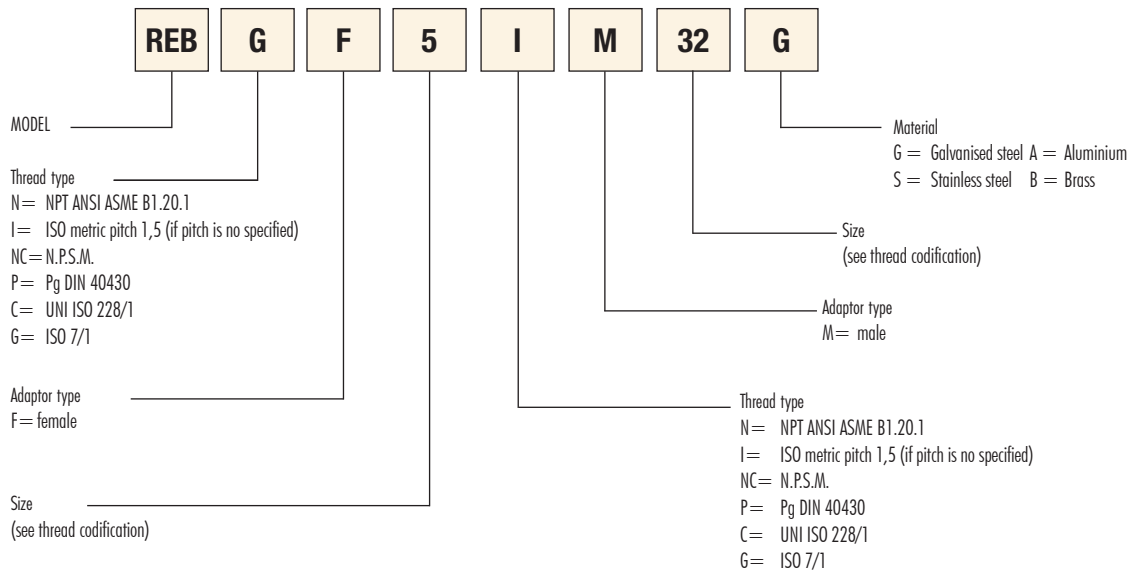


**TECHNICAL NOTES:**

- The silicone O-ring for the IP protection for cylindrical threads (ISO metric) is supplied already assembled
- Available with other threads (example code REB31NG)
- Available in different materials (example code REB31A)

**SPECIAL ADAPTORS (MIXED THREADS)**
**Order code example**

(Adaptor type REB, female 1 1/2" Gk, male M32x1,5, galvanised steel)


**THREAD CODIFICATION**
**NPT, N.P.S.M., UNI ISO 228/1, ISO7/1**

02	01	1	2	3	4	5	6	7	8	9	10	12	14
1/4"	3/8"	1/2"	3/4"	1"	1 1/4"	1 1/2"	2	2 1/2"	3"	3 1/2"	4"	5"	6"

**ISO Metric**

12	16	20	25	32	40	50	63	75	90	100	63X2	75X2	90X2
M12x1,5	M16x1,5	M20x1,5	M25x1,5	M32x1,5	M40x1,5	M50x1,5	M63x1,5	M75x1,5	M90x1,5	M100x1,5	M63x2	M75x2	M90x2

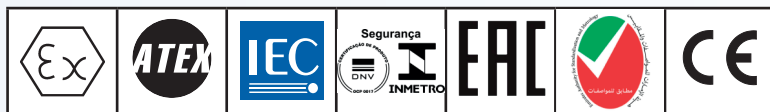
**Pg DIN 40430**

2	3	4	5	6	7	8	9	10
PG9	PG11	PG13,5	PG16	PG21	PG29	PG36	PG42	PG48



# Adaptors REM female - female

Reducers and adaptors are used to join instruments, enclosures, pipes and hubs of different diameter and threads.



<b>Classification:</b> 2014/34/UE	Group II	Category 2GD
<b>Installation:</b> EN 60079.14	zone 1 - zone 2 (Gas)	zone 21 - zone 22 (Dust)
<b>Marking:</b>	CE 0722 Ex II 2 GD Ex db IIC Gb Ex tb IIIC Db IP66/67	
	CE 0722 Ex II 2 GD Ex eb IIC Gb Ex tb IIIC Db IP66/67	
<b>Certification</b>	ATEX CESI 02 ATEX 049X	
	IECEX	IECEX CES 10.0001X

For IEC Ex and others certifications data can be downloaded at [www.elfit.com](http://www.elfit.com)

<b>Standards:</b>	CENELEC EN 60079-0: 2012+A11: 2013, EN 60079-1: 2014, EN 60079-7: 2015, EN 60079-31: 2014 and EUROPEAN DIRECTIVE 2014/34/UE IEC60079-0: 2011, IEC60079-1: 2007-04, IEC60079-7: 2006-07, IEC60079-31: 2008 Directive RoHS 2002/95/CE
-------------------	--

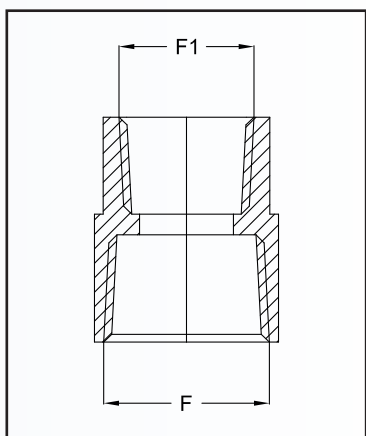
<b>Degree of protection:</b>	IP66/67
------------------------------	---------

## **Operating temperature:**

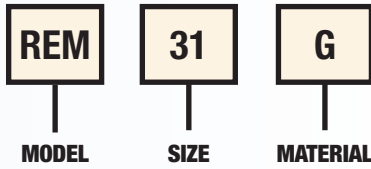
Adaptors	Material	Ambient temperature
REM...	Galvanised steel (G)	-20°C +80°C
REM...	Nickel-plated brass (B), Aluminium alloy (A)	-40°C +150°C
REM...	Stainless steel (S)	-60°C +150°C

Certificates are available on [www.elfit.com](http://www.elfit.com)

<b>SELECTION TABLE OF STANDARD ADAPTORS</b>										
Thread ISO7/1	Ø FEMALE F1									
	1/4"	3/8"	1/2"	3/4"	1"	1 ¼"	1 ½"	2"	2 ½"	
Ø FEMALE F	3/8"	REM3814								
	1/2"	REM114	REM138							
	3/4"	REM214	REM238	REM21						
	1"	REM314	REM338	REM31	REM32					
	1 ¼"	REM414	REM438	REM41	REM42	REM43				
	1 ½"	REM514	REM538	REM51	REM52	REM53	REM54			
	2"	REM614	REM638	REM61	REM62	REM63	REM64	REM65		
	2 ½"			REM71	REM72	REM73	REM74	REM75	REM76	
	3"			REM81	REM82	REM83	REM84	REM85	REM86	REM87



**Order code example of standard adaptors**



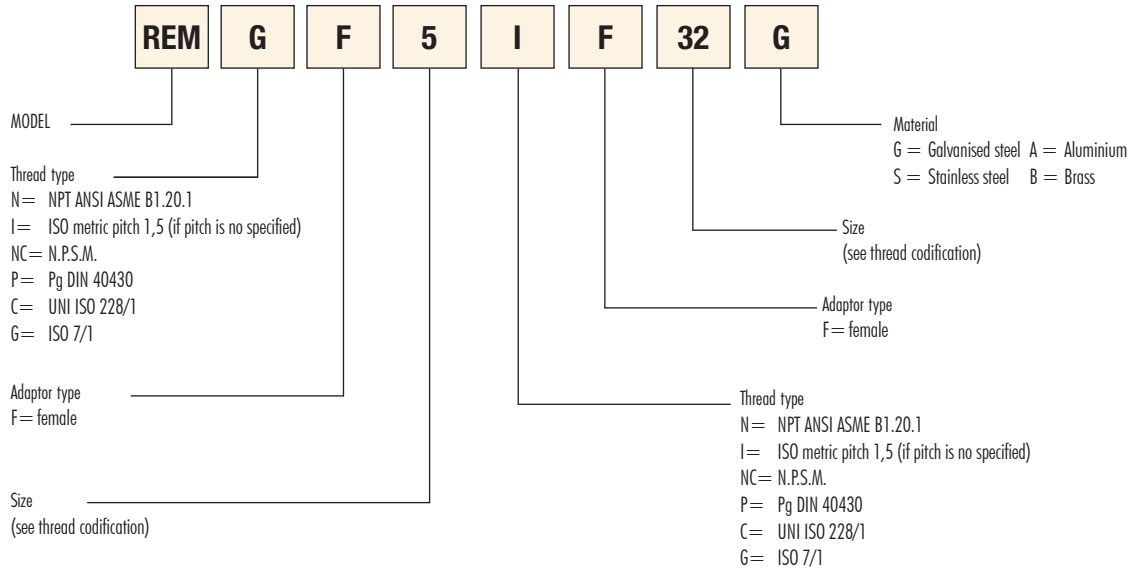
**TECHNICAL NOTES:**

- Available with other threads (example code REM31NG)
- Available in different materials (example code REM31A)

**SPECIAL ADAPTORS (MIXED THREADS)**

**Order code example**

(Adaptor type REM, female 1 1/2" Gk, female M32x1,5, galvanised steel)



**THREAD CODIFICATION**

**NPT, N.P.S.M., UNI ISO 228/1, ISO 7/1**

02	01	1	2	3	4	5	6	7	8	9	10	12	14
1/4"	3/8"	1/2"	3/4"	1"	1 1/4"	1 1/2"	2	2 1/2"	3"	3 1/2"	4"	5"	6"

**ISO Metric**

12	16	20	25	32	40	50	63	75	90	100	63X2	75X2	90X2
M12x1,5	M16x1,5	M20x1,5	M25x1,5	M32x1,5	M40x1,5	M50x1,5	M63x1,5	M75x1,5	M90x1,5	M100x1,5	M63x2	M75x2	M90x2

**Pg DIN 40430**

2	3	4	5	6	7	8	9	10
PG9	PG11	PG13,5	PG16	PG21	PG29	PG36	PG42	PG48

# Adaptors **REN** male - male

Reducers and adaptors are used to join instruments, enclosures, pipes and hubs of different diameter and threads.



<b>Classification:</b> 2014/34/UE	Group II	Category 2GD
<b>Installation:</b> EN 60079.14	zone 1 - zone 2 (Gas)	zone 21 - zone 22 (Dust)
<b>Marking:</b>	CE 0722 Ex II 2 GD Ex db IIC Gb Ex tb IIIC Db IP66/67	
	CE 0722 Ex II 2 GD Ex eb IIC Gb Ex tb IIIC Db IP66/67	
<b>Certification</b>	ATEX CESI 02 ATEX 049X	
	IECEX	IECEX CES 10.0001X

For IEC Ex and others certifications data can be downloaded at [www.elfit.com](http://www.elfit.com)

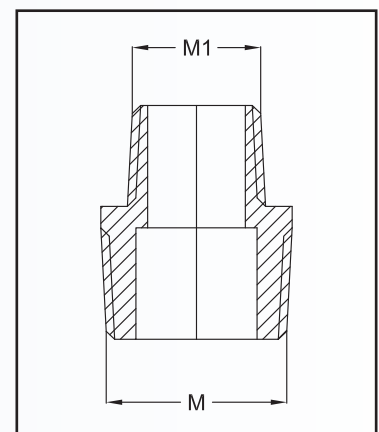
<b>Standards:</b>	CENELEC EN 60079-0: 2012+A11: 2013, EN 60079-1: 2014, EN 60079-7: 2015, EN 60079-31: 2014 and EUROPEAN DIRECTIVE 2014/34/UE IEC60079-0: 2011, IEC60079-1: 2007-04, IEC60079-7: 2006-07, IEC60079-31: 2008 Directive RoHS 2002/95/CE
<b>Degree of protection:</b>	IP66/67

## 🌡️ Operating temperature:

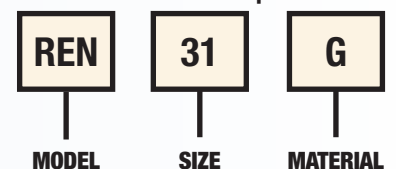
Adaptors	Material	Ambient temperature
REN...	Galvanised steel ( <b>G</b> )	-20°C +80°C
REN...	Nickel-plated brass ( <b>B</b> ), Aluminium alloy ( <b>A</b> )	-40°C +150°C
REN...	Stainless steel ( <b>S</b> )	-60°C +150°C

Certificates are available on [www.elfit.com](http://www.elfit.com)

SELECTION TABLE OF STANDARD ADAPTORS										
Thread ISO7/1	Ø MALE M1									
	1/4"	3/8"	1/2"	3/4"	1"	1 1/4"	1 1/2"	2"	2 1/2"	
Ø MALE M	3/8"	REN3814								
	1/2"	REN114	REN138							
	3/4"	REN214	REN238	REN21						
	1"	REN314	REN338	REN31	REN32					
	1 1/4"	REN414	REN438	REN41	REN42	REN43				
	1 1/2"	REN514	REN538	REN51	REN52	REN53	REN54			
	2"	REN614	REN638	REN61	REN62	REN63	REN64	REN65		
	2 1/2"			REN71	REN72	REN73	REN74	REN75	REN76	
	3"			REN81	REN82	REN83	REN84	REN85	REN86	REN87



Order code example of standard adaptors

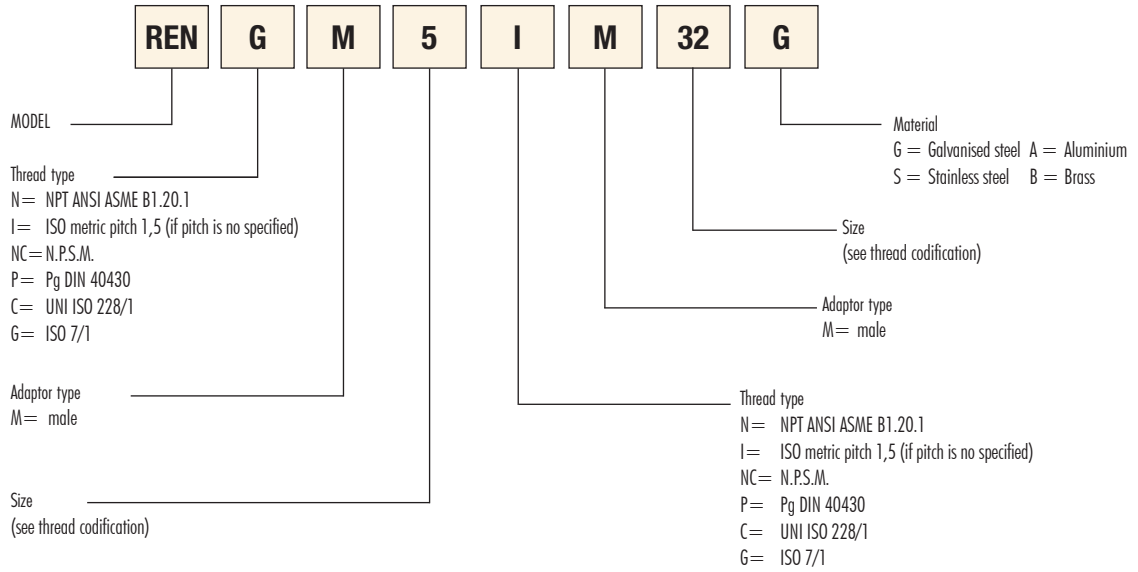


### TECHNICAL NOTES:

- The silicone O-ring for the IP protection for cylindrical threads (ISO metric) is supplied already assembled
- Available with other threads (example code REN31NG)
- Available in different materials (example code REN31A)

**SPECIAL ADAPTORS (MIXED THREADS)**
**Order code example**

(Adaptor type REN, male 1 1/2" Gk, male M32x1,5, galvanised steel)


**THREAD CODIFICATION**
**NPT, N.P.S.M., UNI ISO 228/1, ISO7/1**

02	01	1	2	3	4	5	6	7	8	9	10	12	14
1/4"	3/8"	1/2"	3/4"	1"	1 1/4"	1 1/2"	2	2 1/2"	3"	3 1/2"	4"	5"	6"

**ISO Metric**

12	16	20	25	32	40	50	63	75	90	100	63X2	75X2	90X2
M12x1,5	M16x1,5	M20x1,5	M25x1,5	M32x1,5	M40x1,5	M50x1,5	M63x1,5	M75x1,5	M90x1,5	M100x1,5	M63x2	M75x2	M90x2

**Pg DIN 40430**

2	3	4	5	6	7	8	9	10
PG9	PG11	PG13,5	PG16	PG21	PG29	PG36	PG42	PG48



PLG series plugs are used for close-up unused entries. They feature a hexagonal recessed-type head to ensure the opening with proper tools only.



<b>Classification:</b> 2014/34/UE	Group II	Category 2GD
<b>Installation:</b> EN 60079-14	zone 1 - zone 2 (Gas)	zone 21 - zone 22 (Dust)
<b>Marking:</b>	CE 0722 Ex II 2 GD Ex db IIC Gb Ex tb IIC Db IP66/67	
	CE 0722 Ex II 2 GD Ex eb IIC Gb Ex tb IIC Db IP66/67	
<b>Certification:</b>	ATEX CESI 02 ATEX 049X	
	IECEX	IECEX CES 10.0001X

For IEC Ex and others certifications data can be downloaded at [www.elfit.com](http://www.elfit.com)

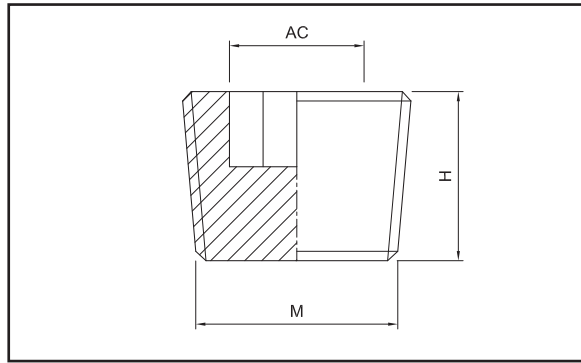
<b>Standards:</b>	CENELEC EN 60079-0: 2012+A11: 2013, EN 60079-1: 2014, EN 60079-7: 2015, EN 60079-31: 2014 and EUROPEAN DIRECTIVE 2014/34/UE IEC60079-0: 2011, IEC60079-1: 2007-04, IEC60079-7: 2006-07, IEC60079-31: 2008 Directive RoHS 2002/95/CE
-------------------	--

<b>Degree of protection:</b>	IP66/67
------------------------------	---------

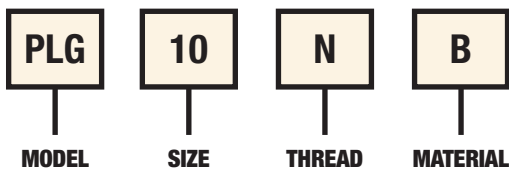
**Operating temperature:**

Close-up plugs	Material	Ambient temperature
PLG...	Galvanised steel (G)	-20°C +80°C
PLG...	Nickel-plated brass (B), Aluminium alloy (A)	-40°C +150°C
PLG...	Stainless steel (S)	-60°C +150°C

Certificates are available on [www.elfit.com](http://www.elfit.com)

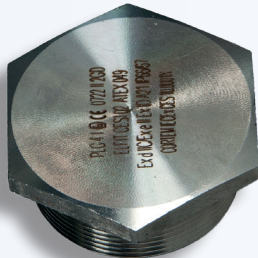
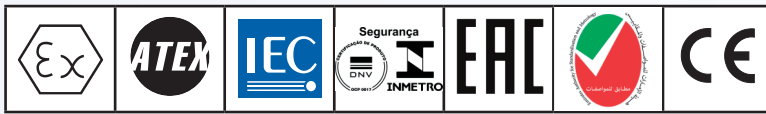

**SELECTION TABLE FOR PLUGS WITH STANDARD CONICAL THREAD**

Code	Thread M	Dimensions in mm		Material	Weight
		AC	H		Kg
PLG02NG	1/4" NPT	8	23	Galvanised steel	0,014
PLG01NG	3/8" NPT	8	14	Galvanised steel	0,024
PLG1NG	1/2" NPT	13	18	Galvanised steel	0,034
PLG2NG	3/4" NPT	17	18	Galvanised steel	0,054
PLG3NG	1" NPT	19	24	Galvanised steel	0,124
PLG4NA	1 1/4" NPT	24	24	Aluminium	0,061
PLG5NA	1 1/2" NPT	35	24	Aluminium	0,063
PLG6NA	2" NPT	36	24	Aluminium	0,109
PLG7NA	2 1/2" NPT	50	30	Aluminium	0,169
PLG8NA	3" NPT	50	30	Aluminium	0,242
PLG10NA	4" NPT	85	30	Aluminium	0,489
PLG12NA	5" NPT	102	32	Aluminium	0,735
PLG14NA	6" NPT	119	32	Aluminium	1,00
PLG02G	1/4" ISO 7/1	8	23	Galvanised steel	0,014
PLG01G	3/8" ISO 7/1	8	14	Galvanised steel	0,024
PLG1G	1/2" ISO 7/1	13	18	Galvanised steel	0,034
PLG2G	3/4" ISO 7/1	17	18	Galvanised steel	0,054
PLG3G	1" ISO 7/1	19	24	Galvanised steel	0,124
PLG4A	1 1/4" ISO 7/1	24	24	Aluminium	0,061
PLG5A	1 1/2" ISO 7/1	35	24	Aluminium	0,063
PLG6A	2" ISO 7/1	36	24	Aluminium	0,109
PLG7A	2 1/2" ISO 7/1	50	30	Aluminium	0,169
PLG8A	3" ISO 7/1	50	30	Aluminium	0,242
PLG10A	4" ISO 7/1	85	30	Aluminium	0,489
PLG12A	5" ISO 7/1	102	32	Aluminium	0,735
PLG14A	6" ISO 7/1	119	32	Aluminium	1,00

**Order code example**

**TECHNICAL NOTES:**

- Available also in stainless steel (example code **PLG3S**)
- Available also in nickel plated brass (example code **PLG1B**)
- Available also in aluminium (example code **PLG2A**)
- Available also in galvanized steel (example code **PLG6G**)

PLG series plugs are used for close-up unused entries. They feature a hexagonal external head to ensure the opening with proper tools only.



<b>Classification:</b> 2014/34/UE	Group II	Category 2GD
<b>Installation:</b> EN 60079.14	zone 1 - zone 2 (Gas)	zone 21 - zone 22 (Dust)
<b>Marking:</b>	CE 0722 Ex II 2 GD Ex db IIC Gb Ex tb IIIC Db IP66/67	
	CE 0722 Ex II 2 GD Ex eb IIC Gb Ex tb IIIC Db IP66/67	
<b>Certification:</b>	ATEX CESI 02 ATEX 049X	
	IECEX	IECEX CES 10.0001X

For IEC Ex and others certifications data can be downloaded at [www.elfit.com](http://www.elfit.com)

<b>Standards:</b>	CENELEC EN 60079-0: 2012, EN 60079-1: 2007, EN 60079-31: 2009 and EUROPEAN DIRECTIVE 2014/34/UE IEC60079-0: 2011, IEC60079-1: 2007-04, IEC60079-7: 2006-07, IEC60079-31: 2008 Directive RoHS 2002/95/CE
-------------------	--

<b>Degree of protection:</b>	IP66/67
------------------------------	---------

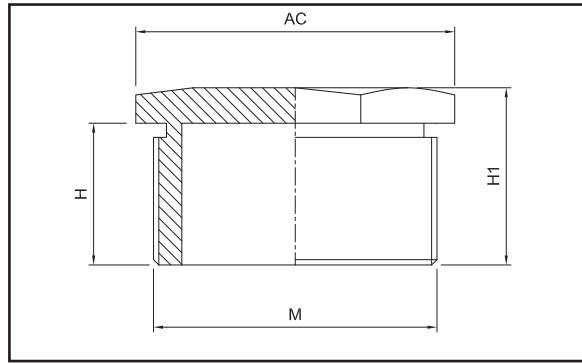
**Operating temperature:**

Close-up plugs	Material	Gaskets	Ambient temperature
PLG...	Galvanised steel (G)	Silicone	-20°C +80°C
PLG...	Nickel-plated brass (B), Aluminium alloy (A)	Silicone	-40°C +150°C
PLG...	Stainless steel (S)	Silicone	-60°C +150°C

Certificates are available on [www.elfit.com](http://www.elfit.com)

ACCESSORIES OPON REQUEST						
Lock nuts *	Thread ISO228	Code	Material	ISO metric thread	Code	Material
	1/4"	DL02G	Galvanised steel	M12x1,5	DL02IB	Nickel-plated brass
	3/8"	DL01G	Galvanised steel	M16x1,5	DL01IB	Nickel-plated brass
	1/2"	DL1G	Galvanised steel	M20x1,5	DL1IB	Nickel-plated brass
	3/4"	DL2G	Galvanised steel	M25x1,5	DL2IB	Nickel-plated brass
	1"	DL3G	Galvanised steel	M32x1,5	DL3IB	Nickel-plated brass
	1 1/4"	DL4G	Galvanised steel	M40x1,5	DL4IB	Nickel-plated brass
	1 1/2"	DL5A	Aluminium	M50x1,5	DL5IB	Nickel-plated brass
	2"	DL6A	Aluminium	M63x1,5	DL6IB	Nickel-plated brass
	2 1/2"	DL7A	Aluminium	M75x1,5	DL7IB	Nickel-plated brass
	3"	DL8A	Aluminium	M90x1,5	DL8IB	Nickel-plated brass
	3 1/2"	DL9A	Aluminium	-	-	-
	4"	DL10A	Aluminium	M100x1,5	DL10IB	Nickel-plated brass

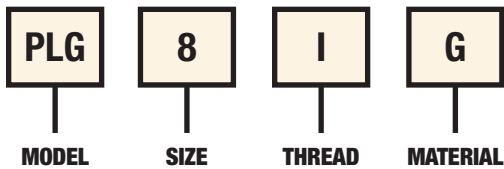
\* For different material contact the sales office.



**SELECTION TABLE FOR PLUGS WITH CYLINDRICAL THREAD**

Code	Thread M	Dimensions in mm			Material	Weight Kg
		AC	H	H1		
PLG02C...	1/4" UNI ISO 228/1	17	16	21	On request	0,014
PLG01C...	3/8" UNI ISO 228/1	22	16	21		0,024
PLG1C...	1/2" UNI ISO 228/1	25	20	25		0,034
PLG2C...	3/4" UNI ISO 228/1	32	20	25		0,054
PLG3C...	1" UNI ISO 228/1	38	24	29		0,124
PLG4C...	1 1/4" UNI ISO 228/1	45	24	29		0,061
PLG5C...	1 1/2" UNI ISO 228/1	55	24	29		0,063
PLG6C...	2" UNI ISO 228/1	65	24	29		0,109
PLG7C...	2 1/2" UNI ISO 228/1	85	24	29		0,169
PLG8C...	3" UNI ISO 228/1	100	24	29		0,242
PLG10C...	4" UNI ISO 228/1	120	24	29		0,489
PLG01I...	M16x1,5	20	16	21	On request	0,014
PLG1I...	M20x1,5	24	16	21		0,024
PLG2I...	M25x1,5	30	16	21		0,034
PLG3I...	M32x1,5	36	16	21		0,054
PLG4I...	M40x1,5	46	16	21		0,124
PLG5I...	M50x1,5	55	16	21		0,061
PLG6I...	M63x1,5	70	18	23		0,063
PLG7I...	M75x1,5	85	18	23		0,109
PLG8I...	M90x1,5	95	18	23		0,169
PLG10I...	M100x1,5	105	18	23		0,242

**Order code example**



**TECHNICAL NOTES:**

- Available also in stainless steel (example code **PLG3IS**)
- Available also in nickel plated brass (example code **PLG1IB**)
- Available also in aluminium (example code **PLG2IA**)
- Available also in galvanized steel (example code **PLG2IG**)
- Available also with PG thread (example code **PLG5PA**)

**THREAD CODIFICATION**

**Pg DIN 40430**

2	3	4	5	6	7	8	9	10
PG9	PG11	PG13,5	PG16	PG21	PG29	PG36	PG42	PG48



**PLG..7 polyamide close-up plugs with cylindrical thread**

PLG series plugs are used for close-up unused entries. They feature a hexagonal external head to ensure the opening with proper tools only.



<b>Classification:</b> 2014/34/UE	Group II	Category 2GD
<b>Installation:</b> EN 60079.14	zone 1 - zone 2 (Gas)	zone 21 - zone 22 (Dust)
<b>Marking:</b>	CE 0722 Ex II 2 GD - Ex e IIC Gb Ex tb IIIC Db IP66/68	
<b>Certification:</b>	ATEX	IMQ 16 ATEX 005X
	IECEX	IECEX IMQ 15.0009X

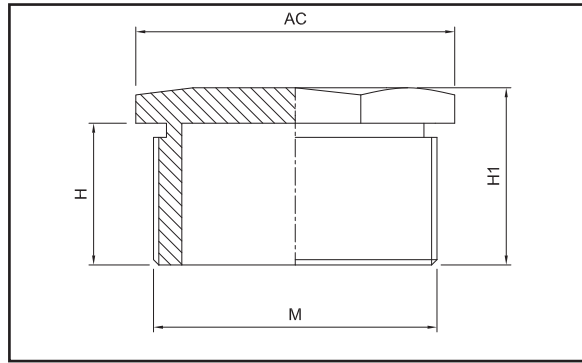
<b>Standards:</b>	CENELEC EN 60079-0: 2012, EN 60079-7: 2007, EN 60079-11: 2012, EN 60079-31: 2014 and EUROPEAN DIRECTIVE 2014/34/UE IEC 60079-0: 2011, IEC 60079-7: 2006, IEC 60079-11: 2012, IEC 60079-31: 2014 Directive RoHS 2002/95/CE
-------------------	---

<b>Ambient Temp.:</b>	-60°C +70°C
-----------------------	-------------

<b>Degree of protection:</b>	IP66/68
------------------------------	---------

Certificates are available on [www.elfit.com](http://www.elfit.com)

ACCESSORIES OPON REQUEST			
Lock nuts	ISO metric thread	Code	Material
	M12x1,5	DL02IXEP	polyamide
	M16x1,5	DL01IXEP	
	M20x1,5	DL11IXEP	
	M25x1,5	DL21IXEP	
	M32x1,5	DL31IXEP	
	M40x1,5	DL41IXEP	
	M50x1,5	DL51IXEP	
	M63x1,5	DL61IXEP	

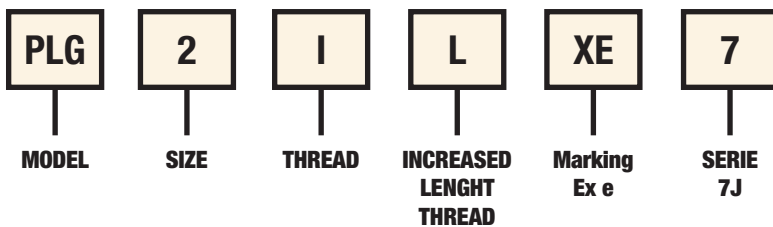


**SELECTION TABLE FOR PLUGS WITH CYLINDRICAL THREAD**

Code polyamide	Thread M	Dimensions in mm			Weight
		AC	H	H1	Kg
PLG02IXE7	M12x1,5	15	10	15	0,002
PLG01ILXE7	M16x1,5	19	15*	19,3	0,003
PLG11LXE7	M20x1,5	23	15*	21	0,005
PLG21LXE7	M25x1,5	28	15*	20,8	0,007
PLG3IXE7	M32x1,5	36	15	22,8	0,012
PLG4IXE7	M40x1,5	46	18	26,5	0,024
PLG5IXE7	M50x1,5	55	18	27,5	0,035
PLG6IXE7	M63x1,5	69	18	27,5	0,051

\* reduced length thread (10mm) upon request.

**Order code example**



**TECHNICAL NOTES:**

- Silicone gaskets
- Black color plug RAL 9005 (Ex e)
- Impact resistance 7J

Elbows with ELF series female-female hubs, ELMF series male-female hubs and ELM series male-male hubs enable the 90° deviations of pipes.



<b>Classification:</b> 2014/34/UE	Group II	Category 2GD
<b>Installation:</b> EN 60079.14	zone 1 - zone 2 (Gas)	zone 21 - zone 22 (Dust)
<b>Marking:</b>	CE 0722 Ex II 2 GD Ex db IIC Gb Ex tb IIIC Db IP66/67	
	CE 0722 Ex II 2 GD Ex eb IIC Gb Ex tb IIIC Db IP66/67	
<b>Certification:</b>	ATEX CESI 01 ATEX 104U	
	IECEX	IECEX CES 15.0005U

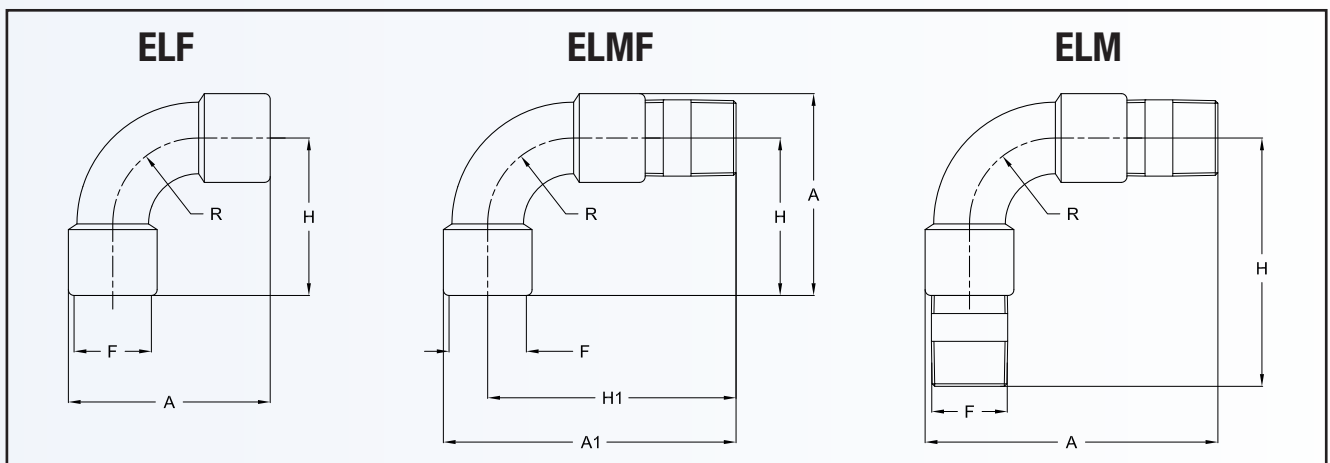
For IEC Ex and others certifications data can be downloaded at [www.elfit.com](http://www.elfit.com)

<b>Standards:</b>	CENELEC EN 60079-0: 2012+A11:2013, EN 60079-1: 2014, EN 60079-7: 2015, EN 60079-31: 2014 and EUROPEAN DIRECTIVE 2014/34/UE IEC60079-0: 2013, IEC60079-1: 2009, IEC60079-7: 2008, IEC60079-31: 2011 Directive RoHS 2002/95/CE
-------------------	--

<b>Operating temp.:</b>	-60°C +150°C
-------------------------	--------------

<b>Degree of protection:</b>	IP66/67
------------------------------	---------

Certificates are available on [www.elfit.com](http://www.elfit.com)



**THREAD CODIFICATION**

NPT, N.P.S.M., UNI ISO 228/1

02	01	1	2	3	4	5	6	7	8	9	10	12	14
1/4"	3/8"	1/2"	3/4"	1"	1 1/4"	1 1/2"	2	2 1/2"	3"	3 1/2"	4"	5"	6"

ISO Metric

12	16	20	25	32	40	50	63	75	90	100	63X2	75X2	90X2
M12x1,5	M16x1,5	M20x1,5	M25x1,5	M32x1,5	M40x1,5	M50x1,5	M63x1,5	M75x1,5	M90x1,5	M100x1,5	M63x2	M75x2	M90x2

**SELECTION TABLE OF ELF 90° ELBOWS**

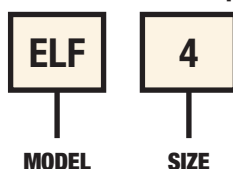
Code In aluminium	Thread F	Dimensions in mm			Weight Kg
		A	H	R	
ELF02	1/4" ISO 7/1	41	55	30	0,09
ELF01	3/8" ISO 7/1	41	55	30	0,08
ELF1	1/2" ISO 7/1	60	45	30	0,12
ELF2	3/4" ISO 7/1	75	55	30	0,10
ELF3	1" ISO 7/1	85	65	35	0,20
ELF4	1 ¼" ISO 7/1	100	75	50	0,39
ELF5	1 ½" ISO 7/1	110	87	50	0,37
ELF6	2" ISO 7/1	120	90	60	0,62
ELF7	2 ½" ISO 7/1	175	135	65	0,88
ELF8	3" ISO 7/1	210	160	85	1,48
ELF10	4" ISO 7/1	270	200	150	3,00

**SELECTION TABLE OF ELMF 90° ELBOWS**

Code In aluminium	Thread F	Dimensions in mm					Weight Kg
		A	A1	H	H1	R	
ELMF02	1/4" ISO 7/1	41	51	55	65	30	0,09
ELMF01	3/8" ISO 7/1	41	51	55	65	30	0,08
ELMF1	1/2" ISO 7/1	60	97	45	85	30	0,17
ELMF2	3/4" ISO 7/1	75	107	55	95	30	0,17
ELMF3	1" ISO 7/1	85	130	65	110	35	0,29
ELMF4	1 ¼" ISO 7/1	100	145	75	125	50	0,52
ELMF5	1 ½" ISO 7/1	110	153	87	125	50	0,50
ELMF6	2" ISO 7/1	120	180	98	143	60	0,79
ELMF7	2 ½" ISO 7/1	175	220	135	185	65	1,43
ELMF8	3" ISO 7/1	210	255	160	205	85	2,20
ELMF10	4" ISO 7/1	270	300	200	245	150	3,93

**SELECTION TABLE OF ELM 90° ELBOWS**

Code In aluminium	Thread F	Dimensions in mm			Weight Kg
		A	H	R	
ELM02	1/4" ISO 7/1	51	65	25	0,09
ELM01	3/8" ISO 7/1	51	65	25	0,08
ELM1	1/2" ISO 7/1	97	56	30	0,21
ELM2	3/4" ISO 7/1	107	56	30	0,22
ELM3	1" ISO 7/1	130	70	35	0,38
ELM4	1 ¼" ISO 7/1	145	85	50	0,64
ELM5	1 ½" ISO 7/1	153	85	50	0,64
ELM6	2" ISO 7/1	180	143	60	0,96
ELM7	2 ½" ISO 7/1	220	185	65	1,99
ELM8	3" ISO 7/1	255	205	85	2,92
ELM10	4" ISO 7/1	300	245	150	4,86

**Order code example**

**TECHNICAL NOTES:**

- Available also with NPT thread (example code **ELF3N**)
- Available upon request with ISO metric thread (example code **ELF4I**)



EM series couplings with female-female hubs, enable the connection between male hubs.



<b>Classification:</b> 2014/34/UE	Group II	Category 2GD
<b>Installation:</b> EN 60079.14	zone 1 - zone 2 (Gas)	zone 21 - zone 22 (Dust)
<b>Marking:</b>	CE 0722 Ex II 2 GD Ex db IIC Gb Ex tb IIIC Db IP66/67	
	CE 0722 Ex II 2 GD Ex eb IIC Gb Ex tb IIIC Db IP66/67	
<b>Certification:</b>	ATEX CESI 01 ATEX 104U	
	IECEX	IECEX CES 15.0005U

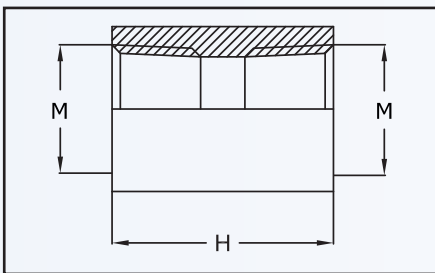
For IEC Ex and others certifications data can be downloaded at [www.elfit.com](http://www.elfit.com)

<b>Standards:</b>	CENELEC EN 60079-0: 2012+A11:2013, EN 60079-1: 2014, EN 60079-7: 2015, EN 60079-31: 2014 and EUROPEAN DIRECTIVE 2014/34/UE IEC60079-0: 2013, IEC60079-1: 2009, IEC60079-7: 2008, IEC60079-31: 2011 Directive RoHS 2002/95/CE
-------------------	--

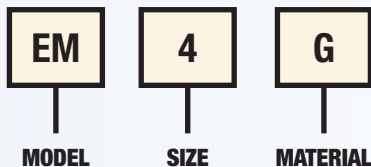
<b>Operating temp.:</b>	-20°C +80°C (-60°C +150°C only in stainless steel)
-------------------------	--

<b>Degree of protection:</b>	IP66/67
------------------------------	---------

Certificates are available on [www.elfit.com](http://www.elfit.com)



Order code example



SELECTION TABLE OF EM COUPLINGS			
Code In galvanised steel	Thread F	Dimensions in mm	Weight
		H	Kg
EM1G	1/2" ISO 7/1	39	0,090
EM2G	3/4" ISO 7/1	39	0,080
EM3G	1" ISO 7/1	51	0,150
EM4G	1 ¼" ISO 7/1	51	0,270
EM5G	1 ½" ISO 7/1	51	0,270
EM6G	2" ISO 7/1	51	0,450
EM7G	2 ½" ISO 7/1	65	0,650
EM8G	3" ISO 7/1	65	0,800
EM10G	4" ISO 7/1	65	1,000
EM12G	5" ISO 7/1	65	2,300
EM14G	6" ISO 7/1	65	2,800

TECHNICAL NOTES:

- Available also with NPT thread (example code EM3NG)
- Available also with UNI ISO228/1 thread (example code EM2CG)
- Available also with ISO METRIC thread (example code EM4IG)
- Available also in stainless steel (example code EM2S)
- Available also in aluminium (example code EM2A)
- Available also in nickel plated brass (example code EM2B)
- For threads equivalence have a look at the correlation table in the last page

NP series nipples with male-male hubs, enable the connection between two female hubs.



<b>Classification:</b> 2014/34/UE	<b>Group II</b>	<b>Category 2GD</b>
<b>Installation:</b> EN 60079.14	<b>zone 1 - zone 2 (Gas)</b>	<b>zone 21 - zone 22 (Dust)</b>
<b>Marking:</b>	CE 0722 Ex II 2 GD Ex db IIC Gb Ex tb IIIC Db IP66/67	
	CE 0722 Ex II 2 GD Ex eb IIC Gb Ex tb IIIC Db IP66/67	
<b>Certification:</b>	ATEX CESI 01 ATEX 104U	
	IECEX	IECEX CES 15.0005U

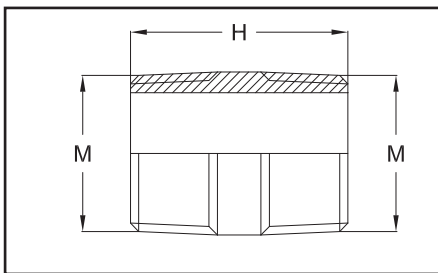
For IEC Ex and others certifications data can be downloaded at [www.elfit.com](http://www.elfit.com)

<b>Standards:</b>	CENELEC EN 60079-0: 2012+A11:2013, EN 60079-1: 2014, EN 60079-7: 2015, EN 60079-31: 2014 and EUROPEAN DIRECTIVE 2014/34/UE IEC60079-0: 2013, IEC60079-1: 2009, IEC60079-7: 2008, IEC60079-31: 2011 Directive RoHS 2002/95/CE
-------------------	--

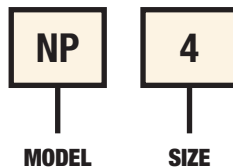
<b>Operating temp.:</b>	-20°C +80°C (-60°C +150°C only in stainless steel)
-------------------------	--

<b>Degree of protection:</b>	IP66/67
------------------------------	---------

Certificates are available on [www.elfit.com](http://www.elfit.com)



Order code example



SELECTION TABLE OF NP NIPPLES			
Code In galvanised steel	Thread F	Dimensions in mm	Weight
		H	Kg
NP1G	1/2" ISO 7/1	48	0,05
NP2G	3/4" ISO 7/1	48	0,06
NP3G	1" ISO 7/1	60	0,10
NP4G	1 1/4" ISO 7/1	55	0,14
NP5G	1 1/2" ISO 7/1	55	0,15
NP6G	2" ISO 7/1	55	0,20
NP7G	2 1/2" ISO 7/1	68	0,45
NP8G	3" ISO 7/1	68	0,70
NP10G	4" ISO 7/1	68	1,0
NP12G	5" ISO 7/1	68	1,25
NP14G	6" ISO 7/1	68	1,27

**TECHNICAL NOTES:**

- Available also with NPT thread (example code NP3NG)
- Available also with UNI ISO228/1 thread (example code NP2CG)
- Available also with ISO METRIC thread (example code NP4IG)
- Available also in stainless steel (example code NP2S)
- Available also in aluminium (example code NP2A)
- Available also in nickel plated brass (example code NP2B)
- For threads equivalence have a look at the correlation table in the last page

## Resin-filled sealing fittings and drain valves features

Our resin-filled sealing fittings can be divided into two different categories: sealing fittings and sealing bushing. The sealing fittings prevent gases, vapours or flames from spreading through the system of pipes in the electrical system. Such products can be divided into:

- EYS** vertical sealing fitting;
- EZS** horizontal sealing fitting;
- EYD** vertical sealing fitting complete of drain valve to breath a possible condensation developed inside the pipes;

The multicable sealing bushings are suitable to be assembled on junction boxes, electrical motors, panel boards and other electrical devices built in accordance to the Ex d IIC method of protection.

The standard sealing bushings are:


- TP** threaded sealing bushing;
- CP** sealing bushing with cylindrical joint;
- NPS** sealing nipple.

The **ECD** drain and breather valves are used both on our EYD and EZD series sealing fittings and in any type of equipment for draining the inner condensation or for breathing out possible inner vapours.

### CRV420 sealing compound


Two-component polyurethan resin for sealing bushing and sealing fittings

CRV 420 resin is an exclusive Elfit product. Its chemical composition has been improved after countless sealing tests, made in collaboration with CESI laboratory. CRV 420 resin has been certified along with the sealing fittings type EYS and EZS, so they need to be sold together and never separated. Sealings have to be made perfectly, in order to block the passage of gases, vapours or flames through pipes systems.



**Ambient Temp.:**

-20°C +100°C



Quantity of resin for each sealing fitting		
Dimensions	EYS/EYD quantity of resin	EZS/EZD quantity of resin
1/2"	35 g	140 g
3/4"	50 g	140 g
1"	100 g	140 g
1 1/4"	240 g	390 g
1 1/2"	240 g	390 g
2"	380 g	570 g
2 1/2"	1250 g	1000 g
3"	1250 g	1000 g

SELECTION TABLE OF RESIN PACKAGE		
Code	Component A	Component B
<b>CRV420-B-100</b>	100 g	20 g
<b>CRV420-B-300</b>	300 g	60 g
<b>CRV420-B-400</b>	400 g	80 g
<b>CRV420-B-1000</b>	1000 g	200 g

For further details about the resin compound preparation and safety information, look the instructions supplied with CRV420 resin.

**PREPARATION OF THE RESIN COMPOUND**

**Characteristics**

Polyuretan black resin (after mixing the two components)  
 Hardening time: around 4 hours  
 Cathalizing time: 24 hours  
 Code: CRV 420

**RESIN (Component A)**

- Black compound
- Code: CRV420H71
- Mixing ratio: 100%

**CATALYST AGENT (Component B)**

- Brown compound
- Code: CRV420H72
- Mixing ratio: 25%

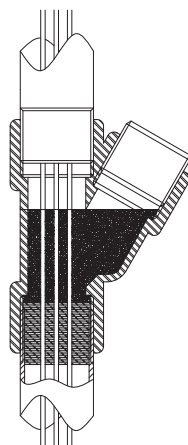
**Ratio of compounds to be mixed**

Ratio 100g (Compound A) with 20g (Compound B)  
 when ready to be used

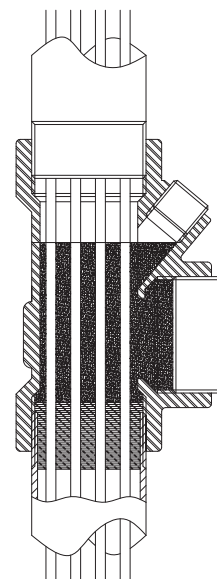
**Time of use for the mixed up compound**

- Ambient temperature equal to 20°C within 30 minutes from the mixing
- Ambient temperature of 15°C within 45 minutes from the mixing

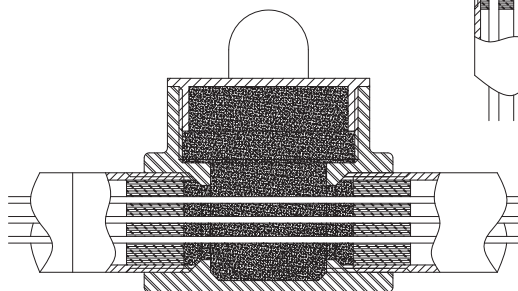
EYS - EYD



EYS - EYD



EZS



**FV... Glass fiber**

The glass fiber is inserted within sealing fittings to avoid that the sealing resin runs into the underlying connection pipe.



SELECTION TABLE OF GLASS FIBER	
Code	Weight
FV-1	250 g
FV-5	500 g
FV-10	1000 g





EYS series sealing fittings prevent the passage of gas, vapours or flames through the pipe system in the electrical installation. They are used for vertical mounting and available in two different shapes, the first for dimensions less than 1", and the second up to 3" with an additional lateral opening for an easy introduction of the fiber. The sealing fittings must be installed as close as possible to the Ex d junction box and in accordance with the standard EN60079-1. They must be filled only with CRV420 resin that has to be requested in the amount indicated in the table. It is not allowed the use of other types of sealing compound.

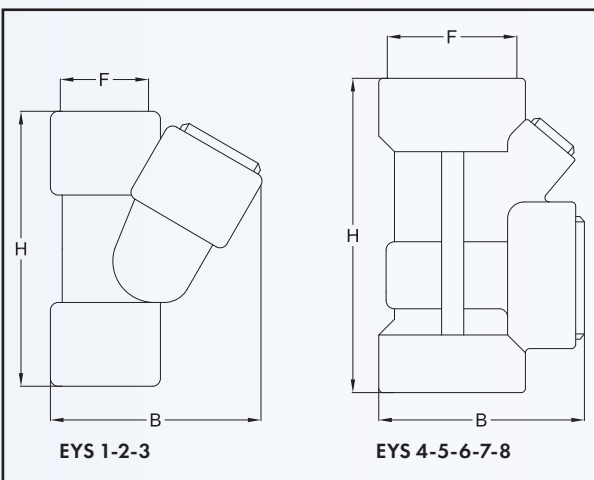


<b>Classification:</b> 2014/34/UE	Group II	Category 2GD
<b>Installation:</b> EN 60079.14	zone 1 - zone 2 (Gas)	zone 21 - zone 22 (Dust)
<b>Marking:</b>	CE 0722 Ex II 2 GD Ex db IIC Gb Ex tb IIIC Db IP66	
<b>Certification:</b>	ATEX	CESI 03 ATEX 085X
	IECEX	IECEX CES 14.0019X

For IEC Ex and others certifications data can be downloaded at [www.elfit.com](http://www.elfit.com)

<b>Standards:</b>	CENELEC EN 60079-0: 2012, EN 60079-1: 2014, EN 60079-31: 2014 and EUROPEAN DIRECTIVE 2014/34/UE IEC60079-0: 2011, IEC60079-1: 2015-06, IEC60079-31: 2013 Directive RoHS 2002/95/CE
<b>Ambient Temp. (EYS):</b>	-20°C +100°C
<b>Operating temperature:</b>	-20°C +100°C
<b>Degree of protection:</b>	IP66

Certificates are available on [www.elfit.com](http://www.elfit.com)



SELECTION TABLE OF EYS VERTICAL SEALING FITTINGS					
Code In aluminium	Thread	Dimensions in mm		Amount of resin gr	Weight Kg
		F	H		
EYS1	1/2" ISO 7/1	77	56	35	0,097
EYS2	3/4" ISO 7/1	87	66	50	0,147
EYS3	1" ISO 7/1	105	82	100	0,242
EYS4	1 1/4" ISO 7/1	145	84	240	0,576
EYS5	1 1/2" ISO 7/1	145	84	240	0,528
EYS6	2" ISO 7/1	150	95	380	0,643
EYS7	2 1/2" ISO 7/1	200	134	1250	1,580
EYS8	3" ISO 7/1	200	134	1250	1,480

**TECHNICAL NOTES:**

- Available also with NPT thread (example code EYS2N)
- Available upon request in stainless steel. Contact our Sales Office for availability.

EYD series sealing fittings are equipped with ECD valve to drain the possible condensation inside the conduits. They are used for vertical mounting and available in two different shapes, the first for dimensions less than 1", and the second up to 3" with an additional lateral opening for easy introduction of the fiber. The sealing fittings have to be installed as close as possible to the Ex d junction box and in accordance with the standard EN60079-1. They must be filled only with CRV420 resin that has to be requested in the amount indicated in the table. It is not allowed the use of other types of sealing compound.

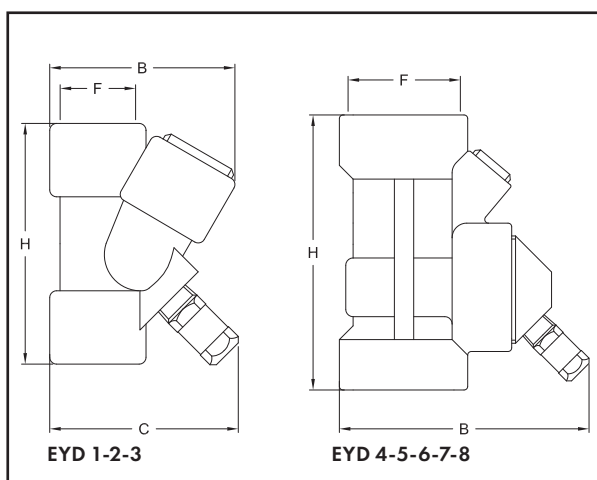


<b>Classification:</b> 2014/34/UE	Group II	Category 2G
<b>Installation:</b> EN 60079.14	zone 1 - zone 2 (Gas)	
<b>Marking:</b>	CE 0722 Ex II 2 G Ex d IIC Gb	
<b>Certification</b>	ATEX	CESI 03 ATEX 085X
	IECEX	IECEX CES 14.0019X

All IEC Ex certification data can be downloaded at [www.elfit.com](http://www.elfit.com)

<b>Standards:</b>	CENELEC EN 60079-0: 2012, EN 60079-1: 2014, EN 60079-31: 2014 and EUROPEAN DIRECTIVE 2014/34/UE IEC60079-0: 2011, IEC60079-1: 2015-06, IEC60079-31: 2013 Directive RoHS 2002/95/CE
<b>Ambient Temp. (EYD):</b>	-20°C +60°C
<b>Operating temperature:</b>	-20°C +100°C

Certificates are available on [www.elfit.com](http://www.elfit.com)



SELECTION TABLE OF EYD VERTICAL SEALING FITTINGS						
Code In aluminium	Thread	Dimensions in mm			Amount of resin gr	Weight Kg
		F	H	B		
EYD1	1/2" ISO 7/1	88	63	67	35	0,280
EYD2	3/4" ISO 7/1	100	72	78	50	0,310
EYD3	1" ISO 7/1	117	85	85	100	0,430
EYD4	1 ¼" ISO 7/1	145	120	120	240	0,720
EYD5	1 ½" ISO 7/1	145	120	120	240	0,600
EYD6	2" ISO 7/1	150	131	131	380	0,820
EYD7	2 ½" ISO 7/1	200	165	165	1250	1,580
EYD8	3" ISO 7/1	200	165	165	1250	1,480

**TECHNICAL NOTES:**

- Available also with NPT thread (example code EYD2N)
- Available upon request in stainless steel. Contact our Sales Office for availability.

EZS series horizontal fittings prevent the passage of gas, vapours or flames through the pipe system in the electrical installation. EZS series can be used both for horizontal and vertical mounting. The sealing fittings have to be installed as close as possible to the Ex d junction box and in accordance with the standard EN60079-1. They must be filled only with CRV420 resin that has to be requested in the amount indicated in the table. It is not allowed the use of other types of sealing compound.

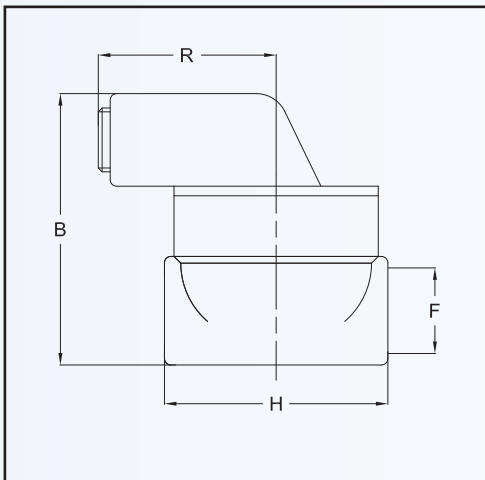


<b>Classification:</b> 2014/34/UE	Group II	Category 2GD
<b>Installation:</b> EN 60079.14	zone 1 - zone 2 (Gas)	zone 21 - zone 22 (Dust)
<b>Marking:</b>	CE 0722 Ex II 2 GD Ex db IIC Gb Ex tb IIIC Db IP66	
<b>Certification:</b>	ATEX CESI 03 ATEX 085X	
	IECEx	IECEx CES 14.0019X

For IEC Ex and others certifications data can be downloaded at [www.elfit.com](http://www.elfit.com)

<b>Standards:</b>	CENELEC EN 60079-0: 2012, EN 60079-1: 2014, EN 60079-31: 2014 and EUROPEAN DIRECTIVE 2014/34/UE IEC60079-0: 2011, IEC60079-1: 2015-06, IEC60079-31: 2013 Directive RoHS 2002/95/CE
<b>Ambient Temp. (EZS):</b>	-20°C +100°C
<b>Operating temperature:</b>	-20°C +100°C
<b>Degree of protection:</b>	IP66

Certificates are available on [www.elfit.com](http://www.elfit.com)



SELECTION TABLE OF EZS HORIZONTAL SEALING FITTINGS						
Code In aluminium	Thread	Dimensions in mm			Amount of resin gr	Weight Kg
		F	H	B		
EZS1	1/2" ISO 7/1	72	83	50	150	0,26
EZS2	3/4" ISO 7/1	72	83	50	140	0,25
EZS3	1" ISO 7/1	74	92	50	140	0,27
EZS4	1 ¼" ISO 7/1	98	110	80	390	0,52
EZS5	1 ½" ISO 7/1	98	110	80	390	0,48
EZS6	2" ISO 7/1	130	120	80	570	0,70
EZS7	2 ½" ISO 7/1	142	160	90	1000	1,50
EZS8	3" ISO 7/1	142	160	90	1000	1,74

**TECHNICAL NOTES:**

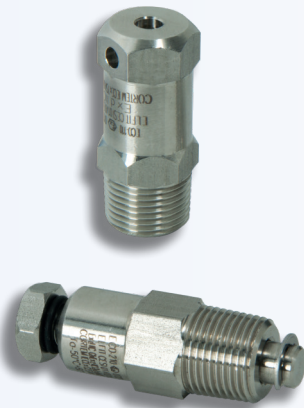
- Available also with NPT thread (example code EZS2N)
- Available upon request in stainless steel







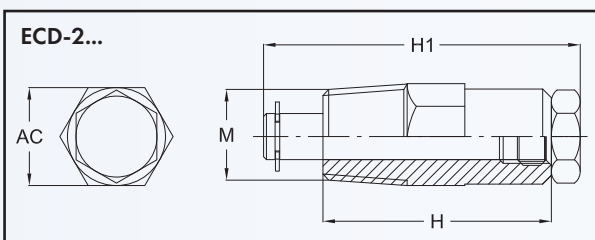
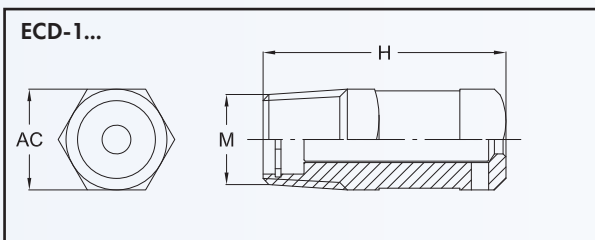
Drain and breather valves are suitable for use in any type of explosion proof enclosure to drain the condensation and vapours developed inside the enclosure.



<b>Classification:</b> 2014/34/UE	Group II	Category 2GD	
<b>Installation:</b> EN 60079.14	zone 1 - zone 2 (Gas)		ECD-1...
	zone 1 - zone 2 (Gas)	zone 21 - zone 22 (Dust)	ECD-2...
<b>Marking:</b>	CE 0722 Ex II 2 G Ex d IIC/IIB Gb		ECD-1...
	CE 0722 Ex II 2 G Ex db IIB/IIC Gb II 2 G Ex eb IIB/IIC Gb II 2 D Ex tb IIIC Db		ECD-2...
	ATEX CESI 01 ATEX 081 U		
<b>Certification:</b>	IECEX	IECEX CES 14.0016U	
	For IEC Ex and others certifications data can be downloaded at <a href="http://www.elfit.com">www.elfit.com</a>		

<b>Standards:</b>	CENELEC EN 60079-0: 2018, EN 60079-1: 2014, EN 60079-7: 2015/A1:2018, EN 60079-31: 2014 and EUROPEAN DIRECTIVE 2014/34/UE IEC60079-0: 2011, IEC60079-1: 2014, IEC 60079-7: 2015, IEC60079-31: 2013 Directive RoHS 2002/95/CE
<b>Operating temp. (IIC):</b>	-60°C +60°C
<b>Operating temp. (IIB):</b>	-60°C +150°C
<b>Degree of protection:</b>	IP66

Certificates are available on [www.elfit.com](http://www.elfit.com)



SELECTION TABLE OF ECD VALVES						
Code In stainless steel AISI 316	Thread	Dimensions in mm			Use	Weight Kg
		F	H	H1		
ECD-110S	3/8" IS07/1	42	-	17	Drain	0,08
ECD-115S	1/2" IS07/1	43	-	22	Drain	0,08
ECDS-110S	3/8" IS07/1	42	-	17	Breather	0,10
ECD-210S	3/8" IS07/1	40	55	17	Drain	0,11
ECD-215S	1/2" IS07/1	40	55	22	Drain	0,20

**TECHNICAL NOTES:**

- Available also in aluminium (example code ECD 110)
- Available also with NPT thread (example code ECD 110NS)
- Available also with ISO METRIC thread

Automatic drainage and breather valves ECDE series are suitable to be used on increased safety, intrinsically safety or watertight enclosures to facilitate the elimination of condensation or vapors developed inside. Thanks to a precise mechanism, it is possible to obtain a continuous drainage and breathing of the junction box, protecting it from the possible formations of internal condensation and thus avoiding the periodic manual discharge, while ensuring a suitable IP degree of protection.

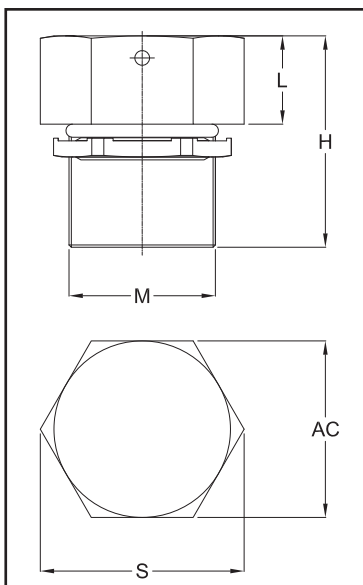


<b>Classification:</b> 2014/34/UE	<b>Group II</b>	<b>Category 2GD</b>
<b>Installation:</b> EN 60079.14	<b>zone 1 - zone 2 (Gas)</b>	<b>zone 21 - zone 22 (Dust)</b>
<b>Marking:</b>	<b>CE 0722 Ex II 2 GD Ex eb IIC Gb Ex tb IIIC Db IP66</b>	
<b>Certification:</b>	<b>ATEX</b>	<b>CML 16 ATEX 1351 X</b>
	<b>IECEX</b>	<b>IECEX CML16.0124X</b>

All IEC Ex certification data can be downloaded at [www.elfit.com](http://www.elfit.com)

<b>Standards:</b>	CENELEC EN 60079-0: 2012, EN 60079-7: 2015, EN 60079-31: 2014 and EUROPEAN DIRECTIVE 2014/34/UE IEC60079-0: 2011, IEC 60079-7: 2015, IEC60079-31: 2013 Directive RoHS 2002/95/CE
<b>Ambient temp.:</b>	-60°C +150°C
<b>Degree of protection:</b>	IP66

Certificates are available on [www.elfit.com](http://www.elfit.com)



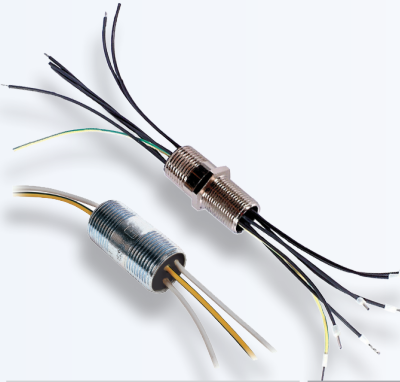
SELECTION TABLE OF ECDE VALVES							
Code In stainless steel AISI 316	Code In nickel-plated brass	Thread	Dimensions in mm				Use
			M	H*	L	S	
ECDE-B1S	ECDE-B1B	M20x1,5	26	13	28	24	Breather
ECDE-B2S	ECDE-B2B	M25x1,5	26	13	35	30	Breather
ECDE-D1S**	ECDE-D1B**	M20x1,5	26	13	28	24	Breather/Drain
ECDE-D2S**	ECDE-D2B**	M25x1,5	26	13	35	30	Breather/Drain

**TECHNICAL NOTES:**

- \* Different lengths for thick junction boxes upon request.
- \*\* When the ECDE are intended for use as a drain, they must be installed at the bottom of the enclosure

The sealed nipples are used to connect explosion-proof enclosures. The cables are sealed through a two-component resin set around each conductor.

Note: Please refer to the Sales Office for the available cables arrangements.



<b>Classification:</b> 2014/34/UE	Group II	Category 2GD
<b>Installation:</b> EN 60079.14	zone 1 - zone 2 (Gas)	zone 21 - zone 22 (Dust)
<b>Marking:</b>	CE 0722 Ex II 2 GD Ex d IIC Gb Ex tb IIIC Db IP66/67	
<b>Certification:</b>	ATEX	CESI 01 ATEX 080U
	IECEX	IECEX CES 10.0003U

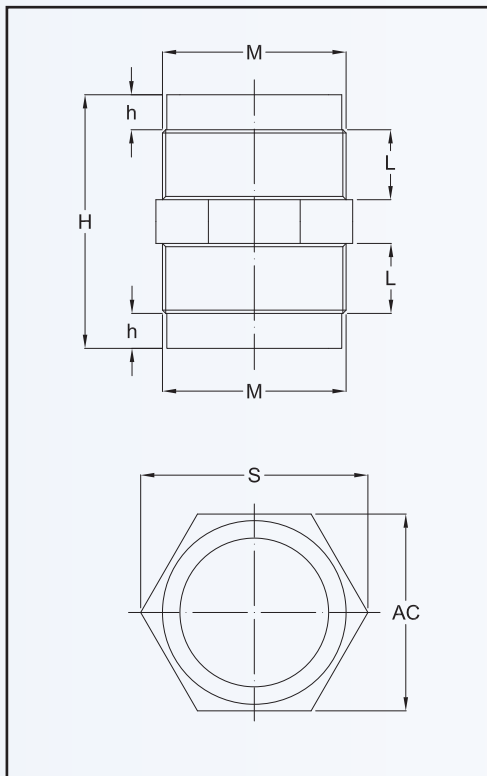
For IEC Ex and others certifications data can be downloaded at [www.elfit.com](http://www.elfit.com)

<b>Standards:</b>	CENELEC EN 60079-0: 2012, EN 60079-1: 2014, EN 60079-31: 2014 and EUROPEAN DIRECTIVE 2014/34/UE IEC60079-0: 2011, IEC60079-1: 2014-06, IEC60079-31: 2013 Directive RoHS 2002/95/CE
-------------------	---

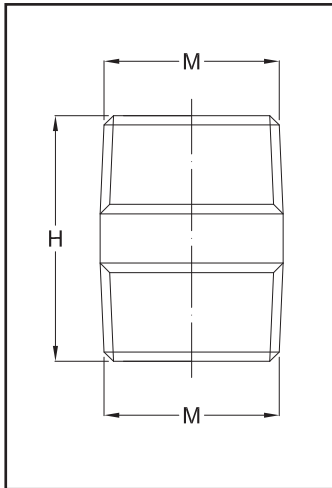
<b>Operating temperature:</b>	-50°C +110°C
-------------------------------	--------------

<b>Degree of protection:</b>	IP66/67
------------------------------	---------

Certificates are available on [www.elfit.com](http://www.elfit.com)



SELECTION TABLE OF ISO METRIC SEALED NIPPLES						
Code In brass	ISO METRIC thread	Dimensions in mm				
		M	H	L	h	S
NPS10	M10x1,5	54	16	8	14	16,5
NPS12	M12x1,5				16	19
NPS16	M16x1,5				20	23,5
NPS20	M20x1,5				24	28
NPS24	M24x1,5				30	34,5
NPS25	M25x1,5				30	34,5
NPS32	M32x1,5				36	42
NPS33	M33x1,5				36	42
NPS36	M36x1,5				40	46,5
NPS38	M38x1,5				42	48,5
NPS40	M40x1,5				45	52
NPS42	M42x1,5				45	52



SELECTION TABLE OF ISO 7/1 SEALED NIPPLES		
Code In galvanized steel	Thread	Dimensions mm
	M	H
NPS1	1/2" ISO 7/1	48
NPS2	3/4" ISO 7/1	48
NPS3	1" ISO 7/1	60
NPS4	1 1/4" ISO 7/1	55
NPS5	1 1/2" ISO 7/1	55

SELECTION TABLE OF NPT SEALED NIPPLES		
Code In galvanized steel	Thread	Dimensions mm
	M	H
NPS1N	1/2" NPT	48
NPS2N	3/4" NPT	48
NPS3N	1" NPT	60
NPS4N	1 1/4" NPT	55
NPS5N	1 1/2" NPT	55

### Order method for sealing nipples

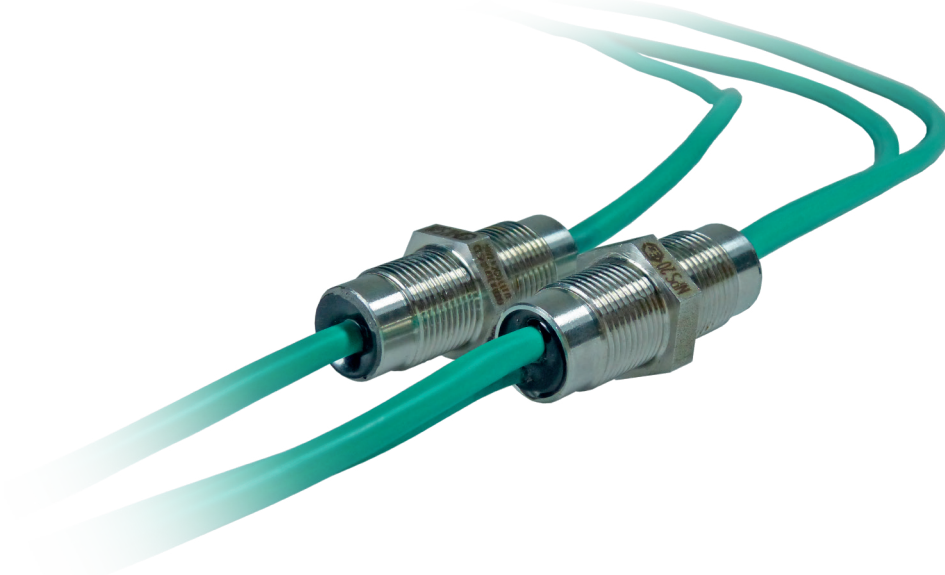
- 1 Indicate the NPS model based on the necessary thread type
- 2 Indicate amount, section, color of cables to be sealed in the nipple
- 3 Indicate the cables length on the two sides
- 4 Indicate the total amount of necessary sealed nipples

### TECHNICAL NOTES:

- The maximum quantity as well as the kind of usable cables are specified on "Maximum quantity and wires type tables" in the following pages
- Available the installation of terminals or connectors
- Possible numeration of cables
- Possible to strip the cables' extremities
- Available also in stainless steel
- Available also in galvanised steel
- It is possible to supply sealing nipples with mixed thread
- Request the lock nuts for the sealing nipples with ISO metric thread

### Upon request it's possible to supply sealing nipples with cables for thermocouples K type

- The maximum quantity and the kind of usable wires are specified on the following pages





**TP sealed bushings for multicables with a threaded joint**

The sealing bushings are used to connect explosion-proof enclosures. The cables are sealed through a two-component resin set around each conductor.



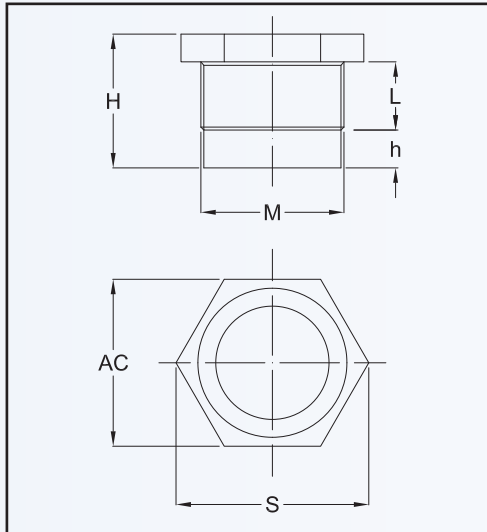
<b>Classification:</b> 2014/34/UE	Group II	Category 2GD
<b>Installation:</b> EN 60079.14	zone 1 - zone 2 (Gas)	
<b>Marking:</b>	CE 0722 Ex II 2 G Ex d IIC Gb	
<b>Certification:</b>	ATEX CESI 01 ATEX 080U	
	IECEX	IECEX CES 10.0003U

For IEC Ex and others certifications data can be downloaded at [www.elfit.com](http://www.elfit.com)

<b>Standards:</b>	CENELEC EN 60079-0: 2012, EN 60079-1: 2014, EN 60079-31: 2014 and EUROPEAN DIRECTIVE 2014/34/UE IEC60079-0: 2011, IEC60079-1: 2014-06, IEC60079-31: 2013 Directive RoHS 2002/95/CE
-------------------	---

<b>Operating temperature:</b>	-50°C +110°C
-------------------------------	--------------

Certificates are available on [www.elfit.com](http://www.elfit.com)



SELECTION TABLE OF SEALING BUSHINGS WITH THREADED JOINT						
Code In brass	ISO METRIC thread	Dimensions in mm				
		M	H	L	h	AC
TP	10	30	15	9	14	16,5
TP	12				16	19
TP	16				20	23,5
TP	24				28	32,5
TP	25				30	34,5
TP	33				36	42
TP	36				40	46,5
TP	38				42	48,5
TP	42				45	52

**Order method for sealing bushings**

- 1 Indicate the TP model based on the necessary thread type
- 2 Indicate amount, section, color of cables to be sealed in the nipple
- 3 Indicate cable length on the two sides
- 4 Indicate the total amount of necessary sealing nipples

**TECHNICAL NOTES:**

- The maximum quantity as well as the kind of usable cables are specified on "Maximum quantity and wires type tables" in the following pages
- Possible to strip the cables' extremities
- Available also in stainless steel
- Request the lock nuts for the block of the sealing bushings

The sealing bushings are used to connect explosion-proof enclosures. The cables are sealed through a two-component resin set around each conductor.



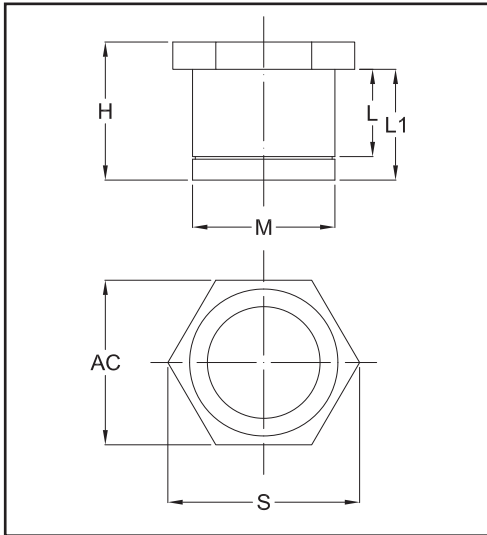
<b>Classification:</b> 2014/34/UE	Group II	Category 2GD
<b>Installation:</b> EN 60079.14	zone 1 - zone 2 (Gas)	
<b>Marking:</b>	CE 0722 Ex II 2 G Ex d IIC Gb	
<b>Certification:</b>	ATEX	CESI 01 ATEX 080U
	IECEX	IECEX CES 10.0003U

For IEC Ex and others certifications data can be downloaded at [www.elfit.com](http://www.elfit.com)

<b>Standards:</b>	CENELEC EN 60079-0: 2012, EN 60079-1: 2014, EN 60079-31: 2014 and EUROPEAN DIRECTIVE 2014/34/UE IEC60079-0: 2011, IEC60079-1: 2014-06, IEC60079-31: 2013 Directive RoHS 2002/95/CE
-------------------	---

<b>Operating temperature:</b>	-50°C +110°C
-------------------------------	--------------

Certificates are available on [www.elfit.com](http://www.elfit.com)



<b>SELECTION TABLE OF SEALING BUSHINGS WITH CYLINDRICAL JOINT</b>						
Code <i>In brass</i>	ISO METRIC thread	Dimensions in mm				
		M	H	L	L1	AC
CP	10	35	25,5	29	14	16,5
CP	12				16	19
CP	16				20	23,5
CP	24				28	32,5
CP	29				32	37
CP	33				36	42
CP	36				40	46,5
CP	38				42	48,5
CP	42				45	52

**Order method for sealing bushings**

- |   |   |
|---|---|
| <p><b>1</b> Indicate the TP model based on the necessary thread type</p> <p><b>2</b> Indicate amount, section, color of cables to be sealed in the nipple</p> | <p><b>3</b> Indicate cable length on the two sides</p> <p><b>4</b> Indicate the total amount of necessary sealing nipples</p> |
|---|---|

**TECHNICAL NOTES:**

- The maximum quantity as well as the kind of usable cables are specified on "Maximum quantity and wires type tables" in the following pages
- Possible to strip the cables' extremities
- Available also in stainless steel
- Request the lock nuts for the block of the sealing bushings

## Maximum quantity and wires type tables

Max. N. of wires	Wires size mm <sup>2</sup>	Rated current for continuous usage for max. temperature of 40°C	Rated Voltage	Thread size for TP - NPS		CP cylindrical Joint size
1 1 3 5 6 6 8 12 15 15 48	0,75	10 A	750 V	M10x1,5 M12x1,5 M16x1,5 M20x1,5 M24x1,5 M25x1,5 - M33x1,5 M36x1,5 M38x1,5 M42x1,5	1/8" 1/4" 3/8" 1/2" - 3/4" - 1" - - 1 1/4" - 1 1/2"	Ø 10 Ø 12 Ø 16 - Ø 24 Ø 25 Ø 29 Ø 33 Ø 36 Ø 38 Ø 42
1 1 3 5 6 6 8 12 15 15 21	1	12 A	1000 V	M10x1,5 M12x1,5 M16x1,5 M20x1,5 M24x1,5 M25x1,5 - M33x1,5 M36x1,5 M38x1,5 M42x1,5	1/8" 1/4" 3/8" 1/2" - 3/4" - 1" - - 1 1/4" - 1 1/2"	Ø 10 Ø 12 Ø 16 - Ø 24 Ø 25 Ø 29 Ø 33 Ø 36 Ø 38 Ø 42
1 1 3 5 6 6 8 12 15 36	1,5	15 A		M10x1,5 M12x1,5 M16x1,5 M20x1,5 M24x1,5 M25x1,5 - M33x1,5 M38x1,5 M42x1,5	1/8" 1/4" 3/8" 1/2" - 3/4" - 1" - 1 1/4" - 1 1/2"	Ø 10 Ø 12 Ø 16 - Ø 24 Ø 25 Ø 29 Ø 33 Ø 38 Ø 42
1 3 3 3 5 12 12 21 24	2,5	20 A		M16x1,5 M20x1,5 M24x1,5 M25x1,5 - M33x1,5 M38x1,5 M42x1,5	3/8" 1/2" - 3/4" - 1" - 1 1/4" - 1 1/2"	Ø 16 - Ø 24 Ø 25 Ø 29 Ø 33 Ø 38 Ø 42
1 2 3 3 5 6 8 8 18	4	27 A		M16x1,5 M20x1,5 M24x1,5 M25x1,5 - M33x1,5 M36x1,5 M38x1,5 M42x1,5	3/8" 1/2" - 3/4" - 1" - - 1 1/4" - 1 1/2"	Ø 16 - Ø 24 Ø 25 Ø 29 Ø 33 Ø 36 Ø 38 Ø 42
1 2 2 2 4 6 6 6 12	6	35 A		M16x1,5 M20x1,5 M24x1,5 M25x1,5 - M33x1,5 M38x1,5 M42x1,5	3/8" 1/2" - 3/4" - 1" - 1 1/4" - 1 1/2"	Ø 16 - Ø 24 Ø 25 Ø 29 Ø 33 Ø 38 Ø 42
1 3 6 6 6	10	49 A		M24x1,5 M33x1,5 M36x1,5 M38x1,5 M42x1,5	3/4" 1" - - 1 1/4" - 1 1/2"	Ø 24 Ø 33 Ø 36 Ø 38 Ø 42

Max. N. of wires	Wires size mm <sup>2</sup>	Rated current for continuous usage for max. temperature of 40°C	Rated Voltage	Thread size for TP - NPS	CP cylindrical Joint size
1 1 3 6 6 6	16	65 A	1000 V	M24x1,5 M25x1,5 3/4" M33x1,5 1" M36x1,5 - M38x1,5 - M42x1,5 1 1/4" - 1 1/2"	Ø 24 Ø 25 Ø 33 Ø 36 Ø 38 Ø 42
1 1 3	25	86 A		M24x1,5 - M25x1,5 3/4" M42x1,5 1 1/4" - 1 1/2"	Ø 24 Ø 25 Ø 42
1 1 3	35	107 A		M24x1,5 - M25x1,5 3/4" M42x1,5 1 1/4" - 1 1/2"	Ø 24 Ø 25 Ø 42
1 1 1	50	132 A		M24x1,5 - M25x1,5 3/4" M33x1,5 1"	Ø 24 Ø 25 Ø 33
1 1	70	165 A		M33x1,5 1" M36x1,5 -	Ø 33 Ø 36

Rated voltage 750V					
Max. N. of wires	Wires size mm <sup>2</sup>	Rated current for continuous usage for max. temperature of 40°C	Thread size for TP - NPS		CP cylindrical joint size
3 3 8 12 16 16 20 20 25 35 45	0,5	5 A	M10x1,5 1/8" M12x1,5 1/4" M16x1,5 3/8" M20x1,5 1/2" M24x1,5 - M25x1,5 3/4" - M33x1,5 1" M36x1,5 - M38x1,5 - M42x1,5 1 1/4" - 1 1/2"	Ø 10 Ø 12 Ø 16 - Ø 24 Ø 25 Ø 29 Ø 33 Ø 36 Ø 38 Ø 42	

Wire capacity range with cables for thermocouples K type - Rated current 100/100V					
Max. N. of wires	Wires size mm <sup>2</sup>	Operating temperature	Thread size for TP - NPS		CP cylindrical joint size
1 1 2 2 5 5 7 7 9	2 x 0,22 2 x 0,50 2 x 0,80	110°C	M12x1,5 M16x1,5 M24x1,5 M25x1,5  M33x1,5 M36x1,5 M38x1,5 M42x1,5	Ø 12 Ø 16 Ø 24 Ø 25 Ø 29 Ø 33 Ø 36 Ø 38 Ø 42	
1 2 2 4 5 7 7 9	2 x 1,00		M16x1,5 M24x1,5 M25x1,5  M33x1,5 M36x1,5 M38x1,5 M42x1,5	Ø 16 Ø 24 Ø 25 Ø 29 Ø 33 Ø 36 Ø 38 Ø 42	
1 2 2 4 5 7 7 9	2 x 1,30 2 x 1,50		M16x1,5 M24x1,5 M25x1,5  M33x1,5 M36x1,5 M38x1,5 M42x1,5	Ø 16 Ø 24 Ø 25 Ø 29 Ø 33 Ø 36 Ø 38 Ø 42	

**TECHNICAL NOTES:**

- The rated current specified in the tables refers to a temperature of 40°C
- For other service temperatures up to 110°C, the derating of current must be evaluated by the end user.
- The resin must fill at least 20% of section (60079-1)
- For the type of cable allowed, please refer to the certificate



Flexible conduits are used for connecting misaligned equipments or equipments subjected to vibrations, such as electrical motors. They are suitable for installation of lighting fixtures and in alternative to rigid conduits when they are difficult to install. SP series flexible conduits have a good flexibility and a very good damping effect against vibrations.



<b>Classification:</b> 2014/34/UE	Group II	Category 2GD
<b>Installation:</b> EN 60079.14	zone 1 - zone 2 (Gas)	zone 21 - zone 22 (Dust)
<b>Marking:</b>	CE 0722 Ex II 2 GD Ex db IIB Gb Ex tb IIC Db IP66/67	
	CE 0722 Ex II 2 GD Ex db IIC Gb Ex tb IIC Db IP66/67	
<b>Certification:</b>	ATEX CESI 00 ATEX 048U	
	IECEX	IECEX CES 14.0011 U

For IEC Ex and others certifications data can be downloaded at [www.elfit.com](http://www.elfit.com)

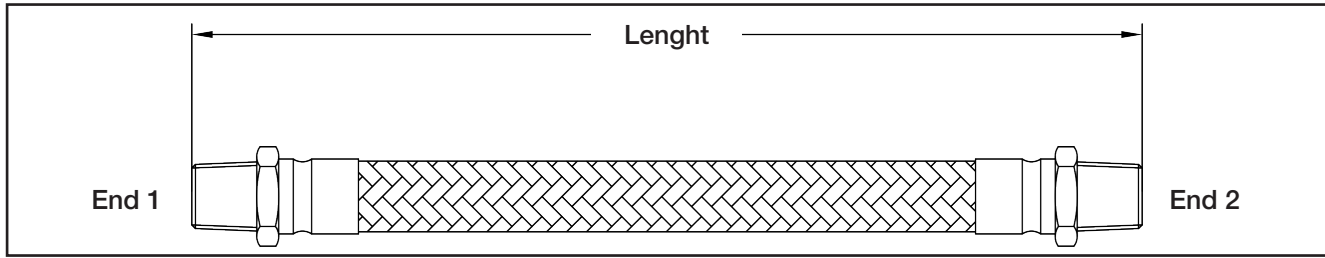
<b>Standards:</b>	CENELEC EN 60079-0: 2012+A11:2013, EN 60079-1: 2014, EN 60079-31: 2014, EN ISO 10807: 1996 and EUROPEAN DIRECTIVE 2014/34/UE IEC60079-0: 2011, IEC60079-1: 2007-04, IEC60079-31: 2008 Directive RoHS 2002/95/CE
-------------------	--

<b>Degree of protection:</b>	IP66/67
------------------------------	---------

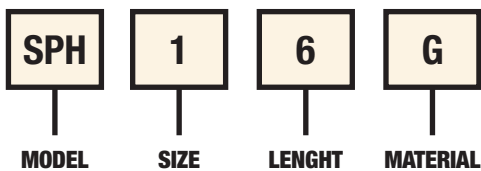
Certificates are available on [www.elfit.com](http://www.elfit.com)

Ambient temperature

	Flexible conduit type	Method of protection	Construction material		Size	Ambient temperature
			Fixed fitting	Revolving fitting		
Fixed fitting	SPH - SPG - SPZ	Ex d IIC	Stainless steel	/	1/2" ÷ 1"	-20°C +150°C
			Galvanized steel	/	1 ¼" ÷ 4"	
	SPH - SPG - SPZ	Ex d IIC	Stainless steel	/	1/2" ÷ 1"	-60°C +150°C
Revolving fitting	SPN - SPI - SPY - SPD SPP - SPE - SPT	Ex d IIB	Stainless steel	Galvanized steel	1/2" ÷ 1"	-20°C +60°C
			Galvanized steel	Galvanized steel	1 ¼" ÷ 4"	
	SPN - SPI - SPY - SPD SPP - SPE - SPT	Ex d IIB	Stainless steel	Stainless steel	1/2" ÷ 1"	-60°C +60°C
	SPRN - SPRI - SPRY - SPRD SPRP - SPRE - SPRT	Ex d IIC	Stainless steel	Galvanized steel	1/2" ÷ 1"	-20°C +60°C
			Galvanized steel	Galvanized steel	1 ¼" ÷ 4"	
	SPRN - SPRI - SPRY - SPRD SPRP - SPRE - SPRT	Ex d IIC	Stainless steel	Stainless steel	1/2" ÷ 4"	-60°C +60°C
RB..	SPRN - SPRI - SPRY - SPRD SPRP - SPRE - SPRT	Ex d IIB	Stainless steel	Stainless steel	1/2" ÷ 4"	-60°C +150°C



End 2 \ End 1	Method of protection IIC	Method of protection IIC		Method of protection IIB		Method of protection IIC		Method of protection IIB (Ta +150°C)	
		Fixed male	Fixed female	Revolving male	Revolving female	Revolving male	Revolving female	Revolving male	Revolving female
Method of protection IIC	Fixed male	<b>SPH</b>	<b>SPG</b>	<b>SPN</b>	<b>SPI</b>	<b>SPRN</b>	<b>SPRI</b>	<b>SPRN</b>	<b>SPRI</b>
	Fixed female		<b>SPZ</b>	<b>SPY</b>	<b>SPD</b>	<b>SPRY</b>	<b>SPRD</b>	<b>SPRY</b>	<b>SPRD</b>
Method of protection IIB	Revolving male			<b>SPP</b>	<b>SPE</b>				
	Revolving female				<b>SPT</b>				
Method of protection IIC	Revolving male					<b>SPRP</b>	<b>SPRE</b>		
	Revolving female						<b>SPRT</b>		
Method of protection IIB	Revolving male							<b>SPRP</b>	<b>SPRE</b>
	Revolving female								<b>SPRT</b>

**Order code example**


Flexible conduits: lenghts and method of protection		
Lenght (mm)		Method of protection
from	to	
≥ 300	≤ 5000	Ex d IIB ÷ Ex d IIC
≥ 5000	≤ 10000	Ex d IIB

Conduit standard lenght	
Cod.	mm
3	300
4	400
5	500
6	600
7	700
8	800
9	900
10	1000

**Thread hubs GAS UNI ISO 7/1**

Size	1	2	3	4	5	6	7	8	9	10
Thread	1/2"	3/4"	1"	1 1/4"	1 1/2"	2	2 1/2"	3"	3 1/2"	4"
Ø min. int.	12	16	25,1	32,2	38,2	50,1	63,1	73,1	73,1	100,1
Curving radius min.	40	60	75	90	110	150	200	225	225	280

**TECHNICAL NOTES:**

- The flexible conduits and related fittings can be welded only by the manufacturer that certifies the method of protection
- Welded fittings: from 1/2" to 1" stainless steel - from 1 1/4" to 4" galvanized steel
- Revolving fittings: galvanized steel
- Flexible conduit with spiralled sheath : stainless steel
- Standard in galvanised steel (example code **SPH56G**)
- Available also in stainless steel (example code **SPH56S**)
- Available also with NPT thread (example code **SPH3N10G**)
- Available also with ISO thread (example code **SPH3I4G**)

ESP series flexible conduits are used to connect increased safety offset equipment or devices subject to vibrations. Compared to traditional explosion-proof conduits, they are lighter, and they are characterized by a mechanical assembly without the use of welding, greatly simplifying installation and maintenance. The fittings are available in nickel-plated brass and stainless steel, while the ESP flexible conduits are covered externally with a UV-resistant polyurethane sheath for a greater protection of the internal metal mesh.



<b>Classification:</b> 2014/34/UE	Group II	Category 2GD
<b>Installation:</b> EN 60079.14	zone 1 - zone 2 (Gas)	zone 21 - zone 22 (Dust)
<b>Marking:</b>	CE 0722 Ex II 2 GD Ex eb IIC Gb - Ex tb IIIC Db	
<b>Certification:</b>	ATEX	IMQ 22 ATEX 057U
	IECEX	IECEX IMQ 22.0009U

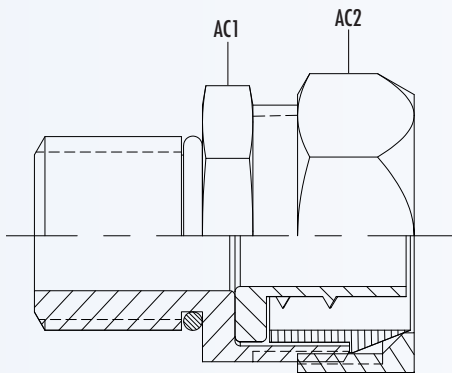
Per tutti i dati di certificazione IEC Ex scaricare il certificato dal sito [www.elfit.com](http://www.elfit.com)

<b>Standards:</b>	CENELEC EN 60079-0: 2018, EN 60079-7: 2015+A1:2018, EN 60079-31: 2014 and EUROPEAN DIRECTIVE 2014/34/UE IEC60079-0: 2018, IEC60079-7: 2017, IEC60079-31: 2013 Direttiva RoHS 2002/95/CE
-------------------	--

<b>Operating temperature:</b>	-60°C +80°C
-------------------------------	-------------

<b>Degree of protection:</b>	IP66
------------------------------	------

Certificates are available on [www.elfit.com](http://www.elfit.com)



FITTINGS KEY OPENINGS (mm)

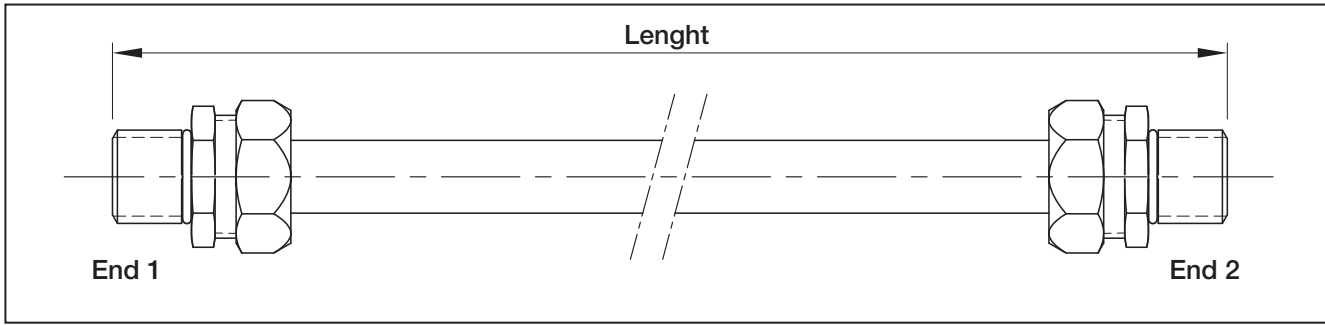
	01	1	2	3	4	5	6
AC1	26	30	37	45	52	62	74
AC2	24	28	35	42	50	58	70

The fitting can be supplied with male or female thread



Locknuts available on request

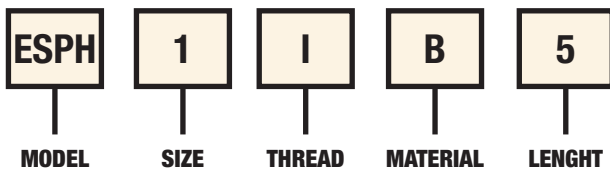
Locknuts	ISO thread	Nickel-plated brass	Stainless steel
	M16x1,5	DL01IB	DL01IS
	M20x1,5	DL11IB	DL11IS
	M25x1,5	DL21IB	DL21IS
	M32x1,5	DL31IB	DL31IS
	M40x1,5	DL41IB	DL41IS
	M50x1,5	DL51IB	DL51IS
	M63x1,5	DL61IB	DL61IS



	<b>Male</b>	<b>Female</b>
<b>Male</b>	<b>ESPH</b>	<b>ESPG</b>
<b>Female</b>		<b>ESPZ</b>

Conduit standard length	
Cod.	mm
3	300
4	400
5	500
6	600
7	700
8	800
9	900
10	1000

**Sample order code**



**Technical data flexible**

Compressive strength 1250 N

Impact resistance 6 J

Tensile strength 1000N

Suspended load resistance 450 N

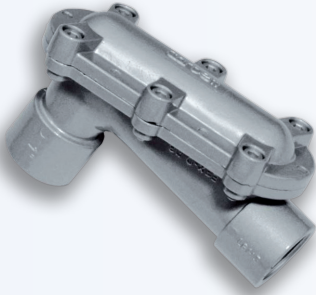
Size	01	1	2	3	4	5	6
ISO thread	M16x1,5	M20x1,5	M25x1,5	M32x1,5	M40x1,5	M50x1,5	M63x1,5
ISO 7/1	3/8"	1/2"	3/4"	1"	1 ¼"	1 ½"	2"
NPT	3/8"	1/2"	3/4"	1"	1 ¼"	1 ½"	2"
Ø min. int.	9,7	13,4	17,9	23,8	31,8	37,7	47,5
Curving radius min.	70	90	120	140	190	240	300

**TECHNICAL NOTES:**

- Available also in nickel brass (example code *ESPH5IB6*)
- Available also in stainless steel (example code *ESPH5IS6*)
- Standard with ISO thread (example code *ESPH3IB6*)
- Available also with ISO 228/1 thread (example code *ESPH3CB6*)
- Available also with NPT thread (example code *ESPH3NB6*)
- Available also three pieces union B.. and R.. series
- For connection and use, see the safety, maintenance and mounting instruction
- Possibility of separate supply flexible and fittings for flexible conduit



LBH series open elbows L shaped with small radius are used for the cables insertion in conduit system of electrical installations. The back opening enables an easy inspection of the installation and easy insertion of electrical cables.

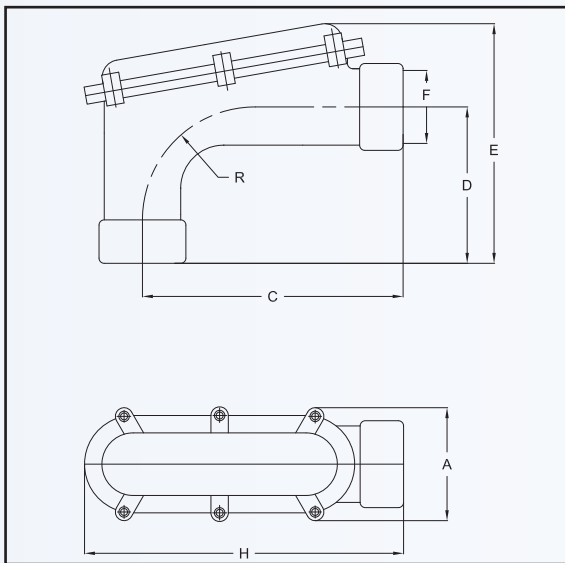


<b>Classification:</b> 2014/34/UE	<b>Group II</b>	<b>Category 2G</b>
<b>Installation:</b> EN 60079-14	<b>zone 1 - zone 2 (Gas)</b>	
<b>Marking:</b>	<b>CE 0722 Ex II 2 G Ex d IIB</b>	
<b>Certification:</b>	<b>ATEX</b>	<b>CESI 03 ATEX 141U</b>

**Standards:** CENELEC EN 60079-0: 2006, EN 60079-1: 2004 and EUROPEAN DIRECTIVE 2014/34/UE IEC60079-0: 2011, IEC60079-1: 2007-04, IEC60079-31: 2008 Directive RoHS 2002/95/CE

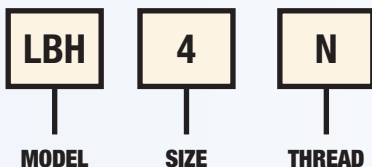
**Ambient Temp.:** -20°C +60°C (Max. operating temperature +80°C)

Certificates are available on [www.elfit.com](http://www.elfit.com)



SELECTION TABLE OF LBH OPEN ELBOWS								
Code In aluminium	Thread	Dimensions in mm						Weight Kg
		F	A	H	C	D	E	
LBH1	1/2" ISO 7/1	70	165	132	45	95	21	0,434
LBH2	3/4" ISO 7/1	70	165	132	45	95	21	0,404
LBH3	1" ISO 7/1	70	168	132	60	112	30	0,455
LBH4	1 ¼" ISO 7/1	100	230	175	83	155	50	1,277
LBH5	1 ½" ISO 7/1	110	265	220	83	132	70	1,142
LBH6	2" ISO 7/1	110	265	220	80	132	70	1,024
LBH7	2 ½" ISO 7/1	136	363	267	140	250	96	3,569
LBH8	3" ISO 7/1	136	363	267	140	250	96	3,171
LBH10	4" ISO 7/1	181	720	605	175	305	125	10,850

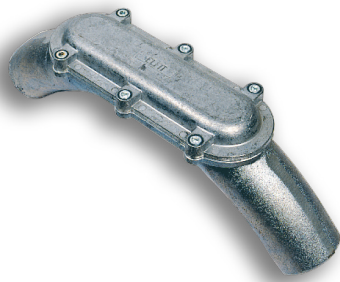
**Order code example**



**TECHNICAL NOTES:**

- Available also with NPT thread (example code LBH3**N**)
- Available also with ISO7/1RP thread (example code LBH2**C**)
- Available also with ISO METRIC thread (example code LBH4**I**)
- 1/4" and 3/8" sizes can be obtained by assembling to the 1/2" LBH1 elbow the corresponding **RE114** or **RE138**

LBHS series open elbows with a large radius are used for the cables insertion in conduit system of electrical installations. The back opening enables an easy inspection of the installation and an easy insertion of electrical cables.

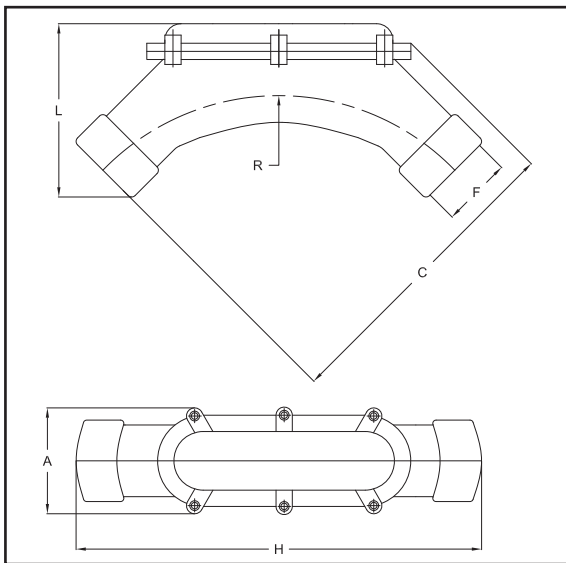


<b>Classification:</b> 2014/34/UE	Group II	Category 2G
<b>Installation:</b> EN 60079.14	zone 1 - zone 2 (Gas)	
<b>Marking:</b>	CE 0722 Ex II 2 G Ex d IIB	
<b>Certification:</b>	ATEX	CESI 03 ATEX 141 U
	TR CU	AVAILABLE <small>All TR CU certification data can be downloaded at <a href="http://www.elfit.com">www.elfit.com</a></small>

<b>Standards:</b>	CENELEC EN 60079-0: 2006, EN 60079-1: 2004 and EUROPEAN DIRECTIVE 2014/34/UE IEC60079-0: 2011, IEC60079-1: 2007-04, IEC60079-31: 2008 Directive RoHS 2002/95/CE
-------------------	--

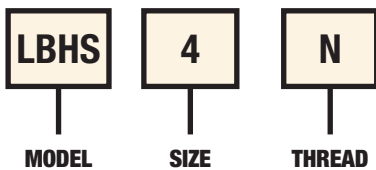
<b>Ambient Temp.:</b>	-20°C +60°C (Max. operating temperature +80°C)
-----------------------	--

Certificates are available on [www.elfit.com](http://www.elfit.com)



SELECTION TABLE OF LBHS OPEN ELBOWS							
Code In aluminium	Thread	Dimensions in mm					Weight Kg
		F	A	H	C	L	
LBHS1	1/2" ISO 7/1	70	305	197	110	195	0,543
LBHS2	3/4" ISO 7/1	70	305	197	110	195	0,467
LBHS3	1" ISO 7/1	70	300	190	110	195	0,629
LBHS4	1 1/4" ISO 7/1	105	400	288	145	260	1,539
LBHS5	1 1/2" ISO 7/1	105	400	288	145	260	1,481
LBHS6	2" ISO 7/1	120	495	348	165	315	2,297
LBHS7	2 1/2" ISO 7/1	142	565	448	205	350	4,473
LBHS8	3" ISO 7/1	149	688	478	220	445	4,914
LBHS10	4" ISO 7/1	164	910	680	310	574	11,110

**Order code example**



**TECHNICAL NOTES:**

- Available also with NPT thread (example code LBHS3N)
- Available also with ISO METRIC thread (example code LBHS4I)

EKC pulling boxes are used in conduit system of electrical plant to facilitate the cables insertion. The back opening enables an easy inspection of the installation and an easy insertion of electrical cables.

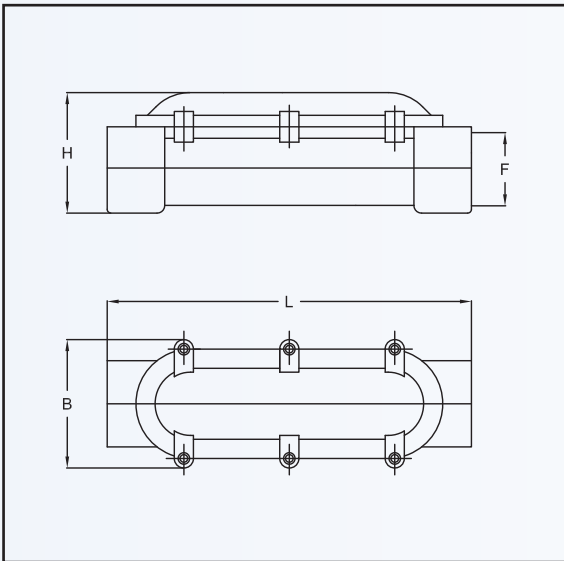


<b>Classification:</b> 2014/34/UE	Group II	Category 2G
<b>Installation:</b> EN 60079-14	zone 1 - zone 2 (Gas)	
<b>Marking:</b>	CE 0722 Ex II 2 G Ex d IIB	
<b>Certification:</b>	ATEX CESI 03 ATEX 141U	

<b>Standards:</b>	CENELEC EN 60079-0: 2006, EN 60079-1: 2004 and EUROPEAN DIRECTIVE 2014/34/UE IEC60079-0: 2011, IEC60079-1: 2007-04, IEC60079-31: 2008 Directive RoHS 2002/95/CE
-------------------	---

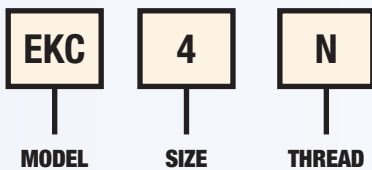
<b>Ambient Temp.:</b>	-20°C +60°C (Max. operating temperature +80°C)
-----------------------	--

Certificates are available on [www.elfit.com](http://www.elfit.com)



SELECTION TABLE OF EKC PULLING BOXES					
Code In aluminium	Thread	Dimensions in mm			Weight Kg
		F	H	L	
EKC1	1/2" ISO 7/1	59	171	70	0,508
EKC2	3/4" ISO 7/1	59	171	70	0,485
EKC3	1" ISO 7/1	64	181	70	0,558
EKC4	1 ¼" ISO 7/1	87	240	99	1,211
EKC5	1 ½" ISO 7/1	87	240	99	1,135
EKC6	2" ISO 7/1	112	298	105	1,745
EKC7	2 ½" ISO 7/1	172	380	138	4,003
EKC8	3" ISO 7/1	172	380	138	3,609
EKC10	4" ISO 7/1	196	755	180	10,320

Order code example



TECHNICAL NOTES:

- Available also with NPT thread (example code EKC3N)
- Available also with ISO METRIC thread (example code EKC4I)



**BC rigid conduits**

Rigid conduits are used in hazardous areas to connect electrical equipment setting up a complete explosion proof system through sealing fittings. The conduits are drawn inside so that all roughness, which could damage the electrical cables, are eliminated.



<b>Installation:</b> EN 60079.14	zone 1 - zone 2 (Gas)
<b>Standards:</b>	EN 60079-0, EN 60079-1
<b>Standard construction:</b>	UNI 7683 galvanized steel conduit Standard bar length: 6 meters Plastic couplings for thread protection ISO7/1 thread
<b>Upon request:</b>	Thread NPT: (example code BC-1N) Bar of 3 m: (example code BC-3/300)

**SELECTION TABLE OF RIGID CONDUITS**

Code	Thread
BC-1	1/2" ISO 7/1
BC-2	3/4" ISO 7/1
BC-3	1" ISO 7/1
BC-4	1 1/4" ISO 7/1
BC-5	1 1/2" ISO 7/1
BC-6	2" ISO 7/1
BC-7	2 1/2" ISO 7/1
BC-8	3" ISO 7/1
BC-10	4" ISO 7/1



## DB...A aluminium bushing

DB...A series bushings are made in aluminium. They are screwed to the pipe end they work as a cable guard. They prevent the cable from rubbing on any pipe burr/edge which could damage its sheath.



**Standard construction:**

Low copper content aluminium alloy body  
ISO 228 thread

**Upon request:**

NPT thread: (example code DB3NA)  
ISO METRIC: (example code DB3IA)  
Galvanised steel (example code DB3G)  
Stainless steel (example code DB3S)

### SELECTION TABLE ALUMINIUM BUSHINGS

Code	Thread	Weight Kg
DB1A	1/2" ISO 7/1	0,012
DB2A	3/4" ISO 7/1	0,014
DB3A	1" ISO 7/1	0,020
DB4A	1 ¼" ISO 7/1	0,025
DB5A	1 ½" ISO 7/1	0,032
DB6A	2" ISO 7/1	0,046
DB7A	2 ½" ISO 7/1	0,062
DB8A	3" ISO 7/1	0,071
DB10A	4" ISO 7/1	0,107
DB12A	5" ISO 7/1	0,134

## DB...P polypropylene bushings

DB...P series bushings, polypropylene made, are screwed to the pipe end and they work as a cable guard. They prevent the cable from rubbing on any pipe burr/edge which could damage its sheath.



**Standard construction:**

Polypropylene thermoplastic moulding  
ISO 228 thread

### SELECTION TABLE FOR POLYPROPYLENE BUSHING

Code	Thread	Weight Kg
DB1P	1/2" ISO 7/1	0,012
DB2P	3/4" ISO 7/1	0,014
DB3P	1" ISO 7/1	0,020
DB4P	1 ¼" ISO 7/1	0,025
DB5P	1 ½" ISO 7/1	0,032
DB6P	2" ISO 7/1	0,046
DB7P	2 ½" ISO 7/1	0,062
DB8P	3" ISO 7/1	0,071
DB10P	4" ISO 7/1	0,107
DB12P	5" ISO 7/1	0,134

DBT series bushings, aluminium made, are screwed to the pipe end and they work as a cable guard. They prevent the cable from rubbing on any pipe burr/edge which could damage its sheath. They are equipped with earth screw for metal parts grounding.



**Standard construction:**

Low copper content aluminium alloy body  
Stainless steel screw  
ISO 228 thread

**Upon request:**

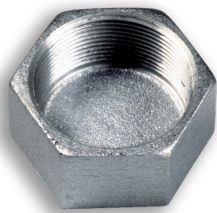
NPT thread: (example code DBT3NA)  
ISO METRIC thread: (example code DBT3IA)  
Galvanised steel (example code DBT3G)  
Stainless steel (example code DBT3S)

### SELECTION TABLE ALUMINIUM BUSHINGS

Code	Thread	Weight Kg
DBT1A	1/2" ISO 7/1	0,016
DBT2A	3/4" ISO 7/1	0,018
DBT3A	1" ISO 7/1	0,024
DBT4A	1 ¼" ISO 7/1	0,033
DBT5A	1 ½" ISO 7/1	0,040
DBT6A	2" ISO 7/1	0,054
DBT7A	2 ½" ISO 7/1	0,070
DBT8A	3" ISO 7/1	0,079
DBT10A	4" ISO 7/1	0,115
DBT12A	5" ISO 7/1	0,142

### MC female closing plugs

MC series female plugs are used to close pipes ends.



**Standard construction:**

Galvanised steel or aluminium  
Standard thread: ISO 7/1 Rp

**Upon request:**

NPT thread: (example code MC3NG)  
ISO METRIC thread: (example code MC3IG)  
Stainless steel (example code MC3S)

### SELECTION TABLE OF FEMALE CLOSING PLUGS

Code	Thread	Material	Weight Kg
MC1G	1/2" ISO 7/1	Galvanised steel	0,035
MC2G	3/4" ISO 7/1	Galvanised steel	0,039
MC3G	1" ISO 7/1	Galvanised steel	0,045
MC4G	1 ¼" ISO 7/1	Galvanised steel	0,052
MC5G	1 ½" ISO 7/1	Galvanised steel	0,285
MC6G	2" ISO 7/1	Galvanised steel	0,335
MC7A	2 ½" ISO 7/1	Aluminium	0,797
MC8A	3" ISO 7/1	Aluminium	0,887
MC10A	4" ISO 7/1	Aluminium	1,119

## DL metal locknuts

DL series locknuts are used to block cable glands or fittings with cylindrical thread on 'Ex e' or 'Ex i' junction box flange or walls with drilling for cables entry.



**Standard construction:**

Galvanised steel o Aluminium (look at the table below)  
ISO 228/1 thread

**Upon request:**

Other threads  
Other materials

### SELECTION TABLE OF DL LOCKNUTS

Code	Thread	Material	Weight Kg
DL1G	1/2" ISO 228/1	Galvanised steel	0,008
DL2G	3/4" ISO 228/1	Galvanised steel	0,011
DL3G	1" ISO 228/1	Galvanised steel	0,013
DL4G	1 ¼" ISO 228/1	Galvanised steel	0,037
DL5A	1 ½" ISO 228/1	Aluminium	0,027
DL6A	2" ISO 228/1	Aluminium	0,034
DL7A	2 ½" ISO 228/1	Aluminium	0,052
DL8A	3" ISO 228/1	Aluminium	0,092
DL10A	4" ISO 228/1	Aluminium	0,132
DL12A	5" ISO 228/1	Aluminium	0,245

## DL...P polyamide locknuts

DL...P series locknuts are used to block polyamide cable glands with cylindrical thread on 'Ex e' or 'Ex i' junction box walls or flange with drilling for cables entry.



**Standard construction:**

Polyamide

**Upon request:**

Marking Ex i: (example code DL02IXIP)

### SELECTION TABLE OF DL LOCKNUTS

Code	ISO thread	Weight Kg
DL02IXEP	M12x1,5	0,004
DL01IXEP	M16x1,5	0,005
DL1IXEP	M20x1,5	0,005
DL2IXEP	M25x1,5	0,006
DL3IXEP	M32x1,5	0,006
DL4IXEP	M40x1,5	0,009
DL5IXEP	M50x1,5	0,013
DL6IXEP	M63x1,5	0,019

### SELECTION TABLE OF DL LOCKNUTS

Code	PG thread	Weight Kg
DL1PXEP	PG7	0,003
DL2PXEP	PG9	0,004
DL3PXEP	PG11	0,005
DL4PXEP	PG13,5	0,005
DL5PXEP	PG16	0,006
DL6PXEP	PG21	0,006
DL7PXEP	PG29	0,009
DL8PXEP	PG36	0,013
DL9PXEP	PG42	0,019
DL10PXEP	PG48	0,026

MT series conduit clamps are used for mounting of cable conduits perpendicular to the support structure.



**Standard construction:**

Galvanised steel  
Galvanized bolts and nuts.

### SELECTION TABLE OF CONDUIT CLAMPS

Code	Thread	Weight Kg
MT1	1/2"	0,093
MT2	3/4"	0,129
MT3	1"	0,150
MT4	1 ¼"	0,194
MT5	1 ½"	0,232
MT6	2"	0,275
MT7	2 ½"	0,310
MT8	3"	0,579
MT10	4"	-

### UBD U-bolts

U-bolts are used to fix rigid cable conduits to flat surfaces.



**Standard construction:**

Galvanised steel

**Upon request:**

Stainless steel (example code UBD3S)

### SELECTION TABLE OF UBD U-BOLTS

Code	Ø cable conduits	Weight Kg
UBD1G	1/2"	0,035
UBD2G	3/4"	0,039
UBD3G	1"	0,045
UBD4G	1 ¼"	0,052
UBD5G	1 ½"	0,285
UBD6G	2"	0,335
UBD7G	2 ½"	0,797
UBD8G	3"	0,887
UBD10G	4"	1,119
UBD12G	5"	1,327



Saddles are used to fix cable conduits to walls or to flat surfaces.



Standard construction:

Galvanised steel or aluminium

Upon request:

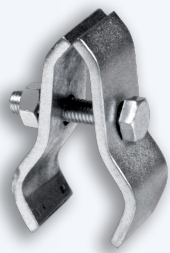
Stainless steel (example code GF3S)

### SELECTION TABLE OF GF SADDLES

Code	Pipe diameter	Threading	Weight Kg
GF1G	21	1/2"	0,028
GF2G	26	3/4"	0,037
GF3G	34	1"	0,045
GF4G	42	1 1/4"	0,087
GF5G	50	1 1/2"	0,115
GF6G	61	2"	0,156
GF7A	77	2 1/2"	0,158
GF8A	90	3"	0,215
GF10A	115	4"	0,284
GF12A	140	5"	-

### MP conduit clamps

MP clamps are used for mounting cable conduits in parallel to the support structure.



Standard construction:

Galvanised steel

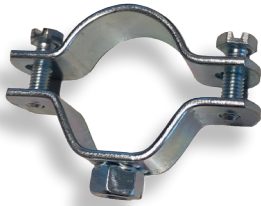
Upon request:

Stainless steel (example code MP3S)

### SELECTION TABLE OF MP CONDUIT CLAMPS

Code	Diameter	Weight Kg
MP1	1/2"	0,138
MP2	3/4"	0,145
MP3	1"	0,198
MP4	1 1/4"	0,530
MP5	1 1/2"	0,590
MP6	2"	-
MP7	2 1/2"	-
MP8	3"	-
MP10	4"	-

Projection electrowelded collar connection packaged in a single bag, suitable for fixing steel pipes but usable for all pipes.



**Standard construction:**

Galvanised steel or aluminium

**Upon request:**

Stainless steel (example code GF3S)

### SELECTION TABLE OF COLLAR

Code	Tube diameter	$\varnothing \div \varnothing$	Int. threading	Weight Kg
CST1	1/2"	20 ÷ 24	M8	0,65
CST2	3/4"	25 ÷ 30	M8	0,77
CST3	1"	32 ÷ 36	M8	0,92
CST4	1 ¼"	38 ÷ 44	M8	0,98
CST5	1 ½"	46 ÷ 50	M8	1,15
CST6	2"	58 ÷ 62	M8	1,24
CST7	2 ½"	74 ÷ 80	M10	1,75
CST8	3"	84 ÷ 89	M10	1,96
CST10	4"	112 ÷ 118	M10	2,55



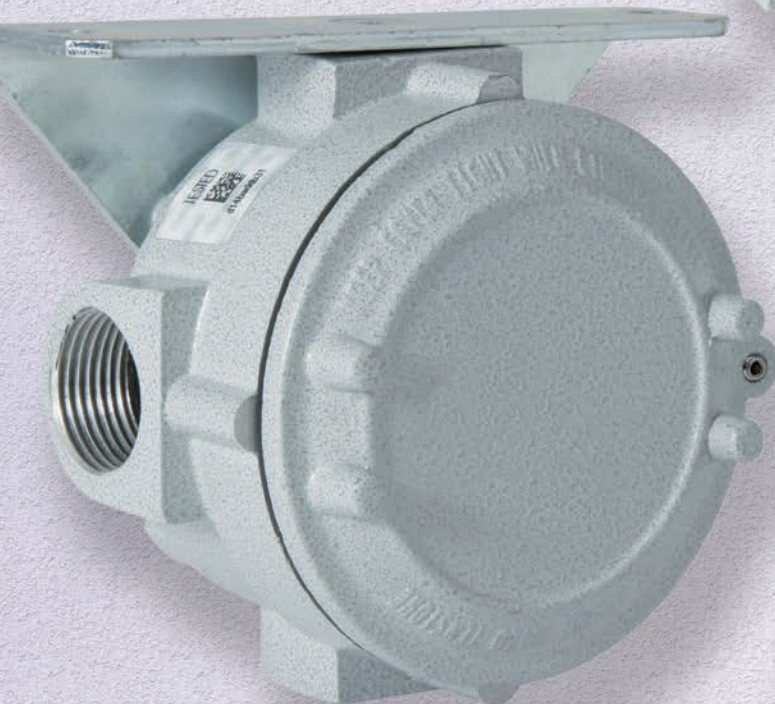
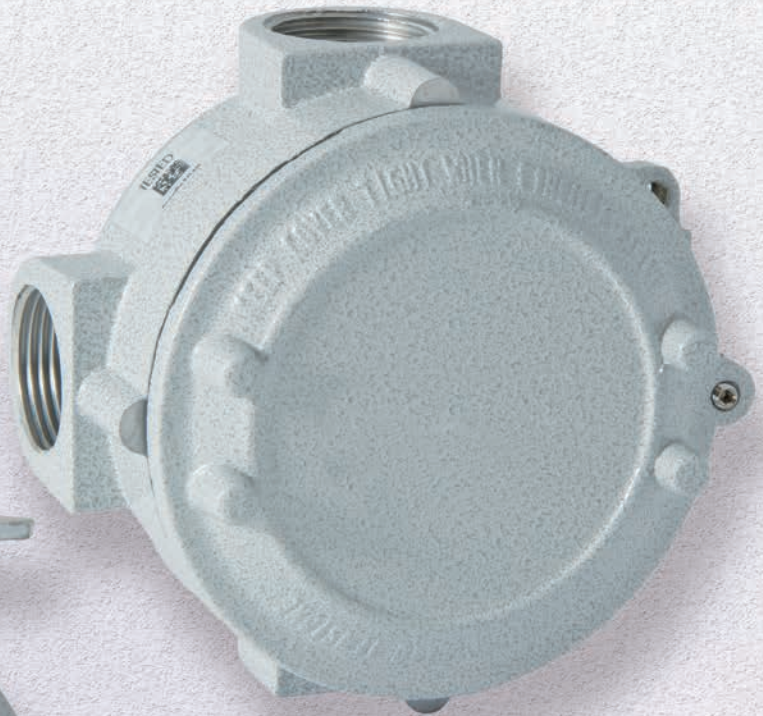




# ELFIT<sup>®</sup>

Electrical FITtings

## Junction and pulling boxes





S series junction boxes are usually installed for the conduit connection and can be used for the insertion of conductors only (empty boxes) or for the derivation of conductors (boxes with terminals).  
The wide range offered includes several models with different sizes and threads.



**EMPTY ENCLOSURES**



<b>Classification:</b> 2014/34/UE	Group II	Category 2GD
<b>Installation:</b> EN 60079.14	zone 1 - zone 2 (Gas)	zone 21 - zone 22 (Dust)
<b>Marking:</b>	CE 0722 Ex II 2 GD Ex d IIC Gb Ex tb IIIC Db IP66/67	
<b>Certification:</b>	ATEX	CESI 03 ATEX 032U
	IECEX	IECEX CES 15.0012U
	TR CU	AVAILABLE

All IEC Ex and TR CU certification data can be downloaded at [www.elfit.com](http://www.elfit.com)

<b>Standards:</b>	CENELEC EN 60079-0: 2012, EN 60079-1: 2007, EN 60079-31: 2009 e and EUROPEAN DIRECTIVE 2014/34/UE IEC60079-0: 2011, IEC60079-1: 2007-04, IEC60079-31: 2008 Directive RoHS 2002/95/CE
-------------------	---

<b>Operating temperature:</b>	-40°C (-20°C) +110°C	CESI 03 ATEX 032U
	-40°C (-20°C) +160°C	CESI 03 ATEX 059U

<b>Degree of protection:</b>	IP66/67
------------------------------	---------

Certificates are available on [www.elfit.com](http://www.elfit.com)

**MECHANICAL FEATURES**

<b>Body and lid:</b>	Low copper content aluminium alloy. Screw-on lid with safety fastening grub screw
<b>Gasket:</b>	Acid/hydrocarbon-resistant silicone, located between body and lid
<b>Entries:</b>	GAS Rp UNI ISO 7/1 thread
<b>Certification label:</b>	Adhesive label located on lid for size 6 and 9 boxes; on body for size 4
<b>Bolts and screws:</b>	Stainless steel
<b>Earth screws:</b>	Stainless steel. On inside and outside of body complete with anti-rotation brackets
<b>Corrosion Resistance:</b>	The STANDARD of the aluminium alloy used by Cortem has passed the tests required by standards EN 60068-2-30 (hot/humid cycles) and EN 60068-2-11 (salt mist tests)

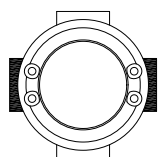
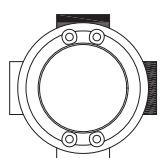
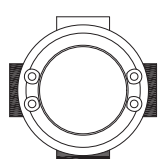
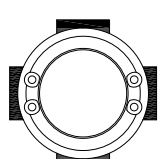
**ACCESSORIES AVAILABLE ON REQUEST/ SPECIAL REQUESTS**

- AISI 316 L stainless steel boxes (Ex. SC16.1S)
- Electropolished AISI 316 L stainless steel boxes (Ex. SC16.1SE)
- Boxes coated with RAL 7035 paint (Ex. SC16.1V)
- External coating in different colour (specify the RAL number)
- Other threads:
  - NPT threads ANSI B1.20.1 (Ex. SC26.1N)
  - GAS UNI ISO 228 thread (Ex. SC26.1C)
  - Metric threads ISO 261/965 (Ex. SC26.1I)

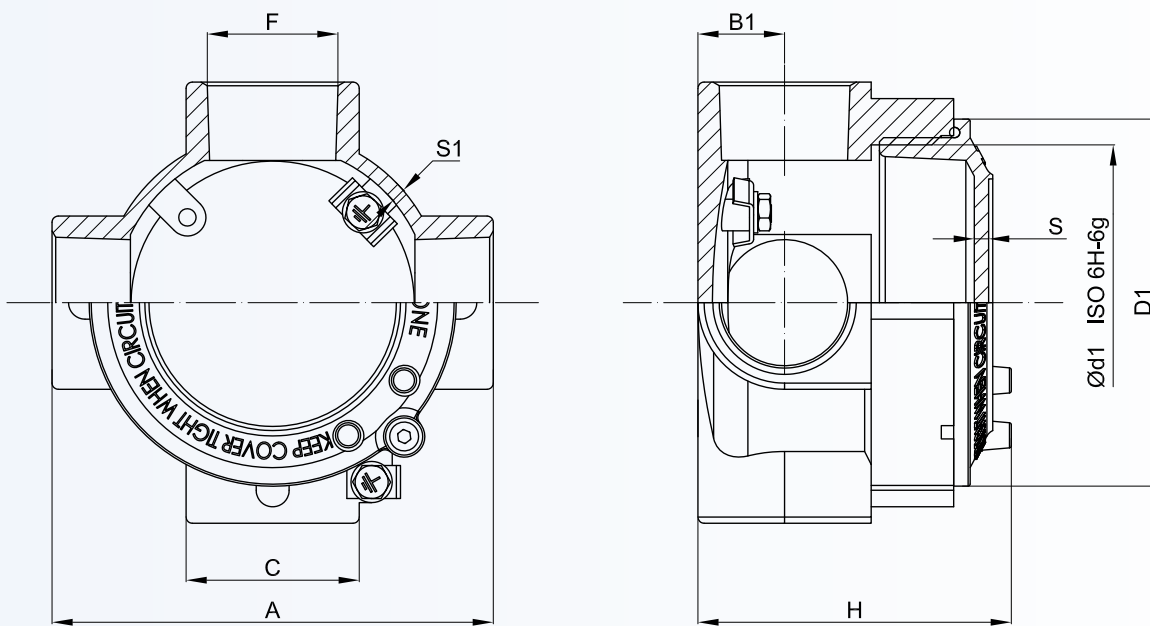


AISI 316 L stainless steel box code SX-36.1SE with electropolished finish

**S SERIES ENCLOSURE SELECTION CHART**

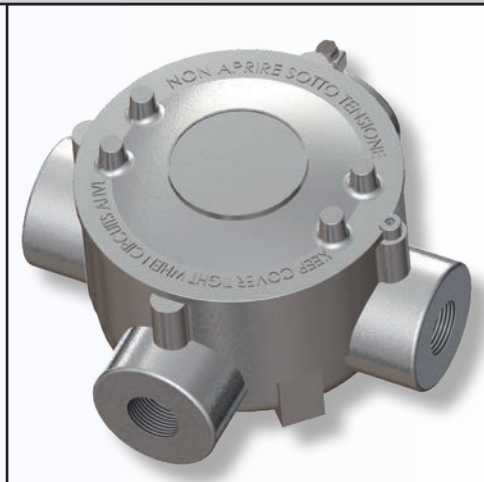
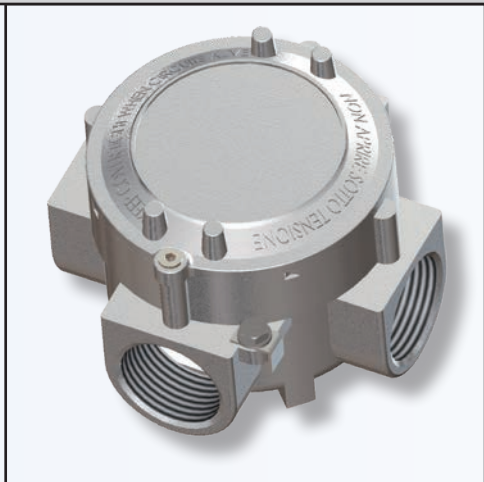
Code	Position of entries	GAS UNI ISO 7/1	Model	Outside dimensions mm					Inside dimensions mm			Weight kg
				A	D1	H	C	B1	Ød1	S	S1	
SC14.1		2 x 1/2"	A	72	65	61	34	17	54x2	3,5	3,5	0,27
SC24.1		2 x 3/4"	A	72	65	61	34	17	54x2	3,5	3,5	0,25
SC16.1		2 x 1/2"	A	100	89	67	34	17	80x2	3,5	3,5	0,41
SC26.1		2 x 3/4"	A	100	89	67	34	17	80x2	3,5	3,5	0,38
SC36.1		2 x 1"	A	107	89	75	42	21	80x2	3,5	3,5	0,48
SC29.1		2 x 3/4"	B	190	146	105	60	30	130x2	4	7	
SC39.1		2 x 1"	B	190	146	105	60	30	130x2	4	7	1,30
SC59.1		2 x 1 1/2"	B	190	146	105	60	30	130x2	4	7	
SC69.1		2 x 2"	B	190	146	110	70	35	130x2	4	7	1,54
SL14.1		2 x 1/2"	A	72	65	61	34	17	54x2	3,5	3,5	0,28
SL24.1		2 x 3/4"	A	72	65	61	34	17	54x2	3,5	3,5	0,24
SL16.1		2 x 1/2"	A	100	89	67	34	17	80x2	3,5	3,5	
SL26.1		2 x 3/4"	A	100	89	67	34	17	80x2	3,5	3,5	0,40
SL36.1		2 x 1"	A	107	89	75	42	21	80x2	3,5	3,5	0,49
SL29.1		2 x 3/4"	B	166	146	105	60	30	130x2	4	7	1,61
SL39.1		2 x 1"	B	166	146	105	60	30	130x2	4	7	1,20
SL59.1		2 x 1 1/2"	B	166	146	105	60	30	130x2	4	7	1,45
SL69.1		2 x 2"	B	166	146	110	70	35	130x2	4	7	1,51
ST14.1		3 x 1/2"	A	72	65	61	34	17	54x2	3,5	3,5	0,27
ST24.1		3 x 3/4"	A	72	65	61	34	17	54x2	3,5	3,5	0,25
ST16.1		3 x 1/2"	A	100	89	67	34	17	80x2	3,5	3,5	0,40
ST26.1		3 x 3/4"	A	100	89	67	34	17	80x2	3,5	3,5	0,38
ST36.1		3 x 1"	A	107	89	75	42	21	80x2	3,5	3,5	0,48
ST29.1		3 x 3/4"	B	190	146	105	60	30	130x2	4	7	1,77
ST39.1		3 x 1"	B	190	146	105	60	30	130x2	4	7	1,70
ST59.1		3 x 1 1/2"	B	190	146	105	60	30	130x2	4	7	1,48
ST69.1		3 x 2"	B	190	146	110	70	35	130x2	4	7	1,53
SX14.1		4 x 1/2"	A	72	65	61	34	17	54x2	3,5	3,5	0,26
SX24.1		4 x 3/4"	A	72	65	61	34	17	54x2	3,5	3,5	
SX16.1		4 x 1/2"	A	100	89	67	34	17	80x2	3,5	3,5	0,39
SX26.1		4 x 3/4"	A	100	89	67	34	17	80x2	3,5	3,5	0,36
SX36.1		4 x 1"	A	107	89	75	42	21	80x2	3,5	3,5	0,43
SX29.1		4 x 3/4"	B	190	146	105	60	30	130x2	4	7	1,94
SX39.1		4 x 1"	B	190	146	105	60	30	130x2	4	7	1,85
SX59.1		4 x 1 1/2"	B	190	146	105	60	30	130x2	4	7	1,51
SX69.1		4 x 2"	B	190	146	110	70	35	130x2	4	7	1,63

DIMENSIONAL DRAWING

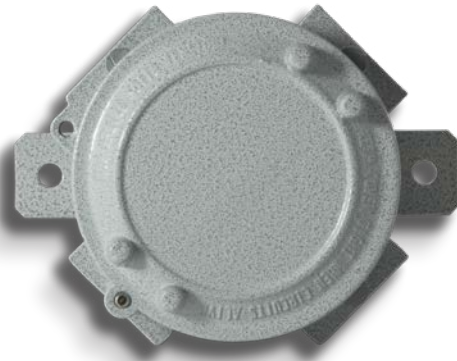


MODEL A

MODEL B



Code	MODEL	F GAS UNI ISO 7/1	Outside dimensions mm				Inside dimensions mm			Weight kg	
			A	D1	H	C	B1	Ød1	S		S1
SB14		2 x 1/2"	90	65	90	39	43	54x2	3,5	3,5	0,34
SB24		2 x 3/4"	90	65	90	39	43	54x2	3,5	3,5	0,34
SB16		2 x 1/2"	110	90	90	45	43	80x2	3,5	5	0,34
SB26		2 x 3/4"	110	90	90	45	43	80x2	3,5	5	0,48
SB36		2 x 1"	114	90	96	45	52	80x2	3,5	5	0,54
SB49		2 x 1 1/4"	180	150	114	60	59	130x2	4	5	0,98
SB59		2 x 1 1/2"	180	150	114	60	59	130x2	4	5	1,25
SB69		2 x 2"	180	150	114	74	71	130x2	4	5	1,58



MODEL SF



MODEL SSC

SF series enclosures (with wall-mounting bracket) and SSC series (with ceiling-mounting bracket) are installed on ducting paths as junction boxes for connecting and branching conductors.

Various different models are available and they can be supplied with multi-pole terminal strips or modular terminals.

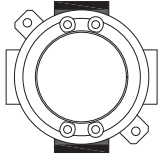
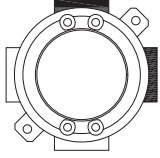
### MECHANICAL AND ELECTRICAL FEATURES

**MOUNTING BRACKETS:** Galvanized steel for SSC. Aluminium for SF.  
*Other features are identical to S series boxes*

### ACCESSORIES AVAILABLE ON REQUEST/ SPECIAL REQUESTS

See S series boxes

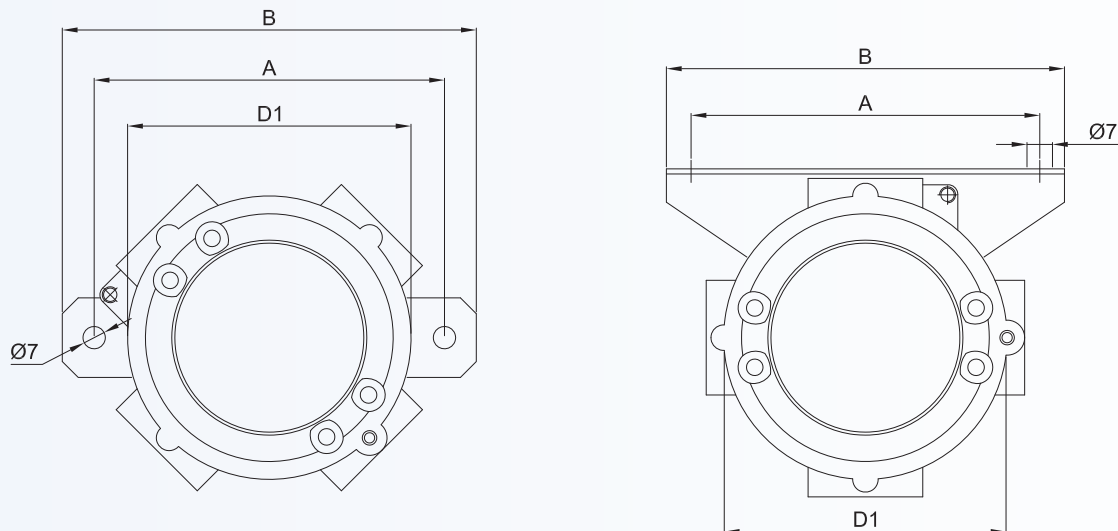
### SF... SSC... SERIES ENCLOSURE SELECTION CHART

Code	Position of entries	GAS UNI ISO 7/1	Outside dimensions mm			Weight kg
		F	D1	A	B	
SFC14.1		2 x 1/2"	65	75	90	0,30
SFC24.1		2 x 3/4"	65	75	90	0,28
SFC16.1		2 x 1/2"	89	110	130	0,45
SFC26.1		2 x 3/4"	89	110	130	0,42
SFC36.1		2 x 1"	89	110	130	0,52
SFC29.1		2 x 3/4"	146	160	180	1,37
SFC39.1		2 x 1"	146	160	180	1,35
SFC59.1		2 x 1 1/2"	146	160	180	
SFC69.1		2 x 2"	146	160	180	1,59
SFL14.1			2 x 1/2"	65	75	90
SFL24.1	2 x 3/4"		65	75	90	0,27
SFL16.1	2 x 1/2"		89	110	130	0,45
SFL26.1	2 x 3/4"		89	110	130	0,44
SFL36.1	2 x 1"		89	110	130	0,53
SFL29.1	2 x 3/4"		146	160	180	1,66
SFL39.1	2 x 1"		146	160	180	1,25
SFL59.1	2 x 1 1/2"		146	160	180	1,50
SFL69.1	2 x 2"		146	160	180	1,56



Code	Position of entries	GAS UNI	ISO 7/1	Outside dimensions mm			Weight kg
				F	D1	A	
SFT14.1			3 x 1/2"	65	75	90	0,30
SFT24.1			3 x 3/4"	65	75	90	0,28
SFT16.1			3 x 1/2"	89	110	130	0,44
SFT26.1			3 x 3/4"	89	110	130	0,42
SFT36.1			3 x 1"	89	110	130	0,52
SFT29.1			3 x 3/4"	146	160	180	1,82
SFT39.1			3 x 1"	146	160	180	1,75
SFT59.1			3 x 1 1/2"	146	160	180	1,53
SFT69.1			3 x 2"	146	160	180	1,58
SFX14.1			4 x 1/2"	65	75	90	0,29
SFX24.1			4 x 3/4"	65	75	90	
SFX16.1			4 x 1/2"	89	110	130	0,43
SFX26.1			4 x 3/4"	89	110	130	
SFX36.1			4 x 1"	89	110	130	0,47
SFX29.1			4 x 3/4"	146	160	180	1,98
SFX39.1			4 x 1"	146	160	180	1,90
SFX59.1			4 x 1 1/2"	146	160	180	1,56
SFX69.1			4 x 2"	146	160	180	1,68
SSC14.1			3 x 1/2"	65	65	80	0,38
SSC24.1			3 x 3/4"	65	65	80	0,36
SSC16.1			3 x 1/2"	89	110	125	0,57
SSC26.1			3 x 3/4"	89	110	125	0,54
SSC36.1			3 x 1"	89	110	125	0,64
SSC29.1			3 x 3/4"	146	130	150	1,94
SSC39.1			3 x 1"	146	130	150	1,91
SSC59.1			3 x 1 1/2"	146	130	150	
SSC69.1			3 x 2"	146	130	150	2,15

DIMENSIONAL DRAWING



**TERMINAL BOXES**


<b>Classification:</b> 2014/34/UE	Group II	Category 2GD
<b>Installation:</b> EN 60079.14	zone 1 - zone 2 (Gas)	zone 21 - zone 22 (Dust)
<b>Marking:</b>	CE 0722 Ex II 2 GD Ex db IIC T.. - Ex tb IIIC T.. °C Db IP66/67	
<b>Certification:</b>	ATEX	CESI 01 ATEX 105X
	IECEX	IECEX CES 22.0011

All IEC Ex and certification data can be downloaded at [www.elfit.com](http://www.elfit.com)

<b>Standards:</b>	CENELEC EN 60079-0: 2018, EN 60079-1: 2014, EN 60079-7: 2015/18, EN 60079-11: 2012, EN 60079-1: 2014 ed alla DIRETTIVA EUROPEA 2014/34/UE IEC60079-0: 2018, IEC60079-1: 2014, IEC60079-7: 2015/18, Direttiva RoHS 2002/95/CE
<b>Operating temperature:</b>	-40°C +150°C
<b>Degree of protection:</b>	IP66/67

**ELECTRICAL FEATURES**

	<b>Terminal boxes "Ex d"</b>	<b>Terminal boxes "Ex e" e "Ex i"</b>
<b>Rated voltage:</b>	750 Vac/dc	630 Vac/dc
<b>Rated frequency:</b>	50 ÷ 60 Hz	50 ÷ 60 Hz
<b>Terminal cross-sectional area:</b>	1,5 mm <sup>2</sup> ÷ 70 mm <sup>2</sup>	5 mm <sup>2</sup> ÷ 25 mm <sup>2</sup>
<b>Rated current:</b>	8 A ÷ 175 A	5,5 A ÷ 65 A
<b>Max. current density:</b>	2.5 ÷ 6.6 A/mm <sup>2</sup>	3 ÷ 6.6 A/mm <sup>2</sup>

**CHART 1**

Ex db rated terminal strips			
Ambient temperature	Terminal material	Temperature class	Maximum surface temperature
-20°C +40°C -40°C +40°C	Polyamide (PA)	T6	T85°C
-20°C +65°C -40°C +65°C	Melamine (KrG) Wemid Stamin (KrS)	T5	T100°C
-20°C +150°C -40°C +150°C	Ceramic (Steatite)	T3	T200°C

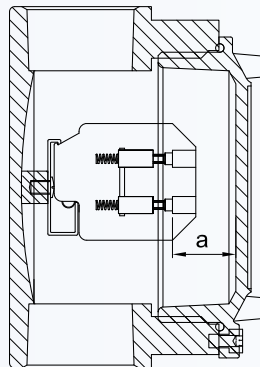
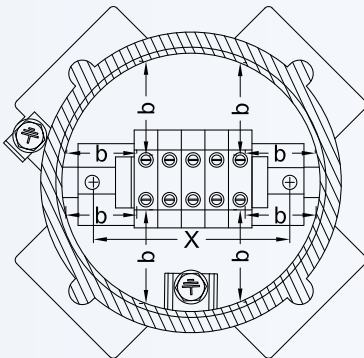
**CHART 2**

Ex eb or Ex i rated terminal strips (ATEX-certified terminals)			
Ambient temperature	Terminal material	Temperature class	Maximum surface temperature
-20°C +40°C -40°C +40°C	Polyamide (PA)	T6	T85°C
-20°C +65°C -40°C +65°C	Melamine (KrG) Wemid Stamin (KrS)	T5	T100°C
-20°C +80°C -40°C +80°C	Melamine (KrG) Stamin (KrS) Ceramic (Steatite)	T4	T135°C

Ex d IIC rated enclosures		CROSS-SECTIONAL AREA AND MAXIMUM NUMBER OF TERMINALS								
Enclosure type	Size	1,5	2,5	4	6	10	16	25	35	70
S.1 - SB	14-24	-	-	3	-	-	-	-	-	-
S.1 - SB	16-26-36	8	8	6	-	-	-	-	-	-
S.1	29-39-59-69	16	16	12	9	7	6	4	4	3
SB	49-59-69	16	16	12	10	8	7	5	5	4
Maximum current (A)	at 40°C	10	12,5	20	24	30	48	75	105	175
	at 65°C at 150°C	8	10,5	16	20	24	40	65	88	150
Maximum current density (A/mm <sup>2</sup> ) for terminals and cables		6,6	5	5	4	3	3	3	3	2,5
Maximum current (A) referring to 35% of the max. number of terminals as given in the table	at 40°C	13	19,5	24	30	50	64	100	140	210
	at 65°C at 150°C	10	12,5	20	24	30	48	75	105	175
Maximum current density (A/mm <sup>2</sup> ) for terminals and cables referring to 35% of the max. number of terminals as given in the table		8,5	7	6	5	5	4	4	4	3
Min.-max. rated voltage (V)		420 - 750								

Minimum distances for Ex db rated enclosures with terminals

Enclosure type	Size	Minimum surface distance		S.1	SB
		a min.	b+b min.	x	x
S.1 - SB	14-24	6	20	40	40
S.1 - SB	16-26-36			58.5	50
S.1	29-39-59-69			100	85
SB	49-59-69				



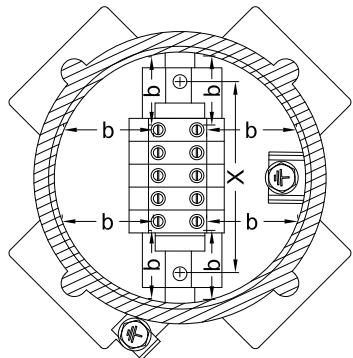
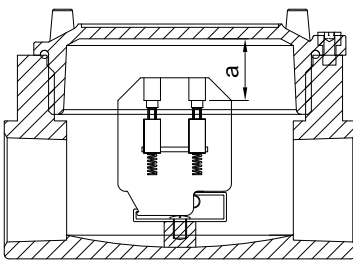
Enclosure code SFL-36.1 with 3 x AKZ-2.5 terminals and 1 x AKE2.5 earth terminal

Ex eb rated enclosures		CROSS-SECTIONAL AREA AND MAXIMUM NUMBER OF TERMINALS															
Enclosure type	Size	1,5			2,5			4			6			10			
		Tab 1	Tab 2	Tab 3	Tab 1	Tab 2	Tab 3	Tab 1	Tab 2	Tab 3	Tab 1	Tab 2	Tab 3	Tab 1	Tab 2	Tab 3	
S.1 - SB	14-24	-	-	-	-	-	-	3	-	-	-	-	-	-	-	-	-
S.1 - SB	16-26-36	8	8	8	8	8	8	6	6	6	-	-	-	-	-	-	-
S.1	29-39-59-69	16	16	16	16	16	16	16	14	14	9	9	9	7	7	7	7
SB	49-59-69	16	16	16	16	16	16	16	14	14	10	10	9	8	7	7	7
Maximum current (A)	at 40°C	8			10,5			17			20			24			
	at 65°C	5,5			7,5			12			14			17			
	at 150°C																
Maximum current density (A/mm <sup>2</sup> ) for terminals and cables		6,6			5			5			4			3			
Min.-max. rated voltage (V)		275 - 630															

Ex eb rated enclosures		CROSS-SECTIONAL AREA AND MAXIMUM NUMBER OF TERMINALS					
Enclosure type	Size	16			25		
		Tab 1	Tab 2	Tab 3	Tab 1	Tab 2	Tab 3
S.1 - SB	14-24	-	-	-	-	-	-
S.1 - SB	16-26-36	-	-	-	-	-	-
S.1	29-39-59-69	6	6	6	4	4	4
SB	49-59-69	7	6	6	5	4	4
Maximum current (A)	at 40°C	40			65		
	at 65°C	29			47		
	at 150°C						
Maximum current density (A/mm <sup>2</sup> ) for terminals and cables		3			3		
Min.-max. rated voltage (V)		275 - 630					



Enclosure code SFL-26.1 with 3 x RP-4 terminals and 1 x TR-2 earth terminal



Minimum distances for Ex eb rated enclosures with terminals

Tab 1	Enclosure type	Size	Minimum surface distance		S.1	SB
			a min.	b+b min.		
	S.1 - SB	14-24	6	20	x	x
S.1 - SB	16-26-36	40			40	
S.1	29-39-59-69	58.5			50	
SB	49-59-69	100			85	

Tab 2	Enclosure type	Size	Minimum surface distance		S.1	SB
			a min.	b+b min.		
	S.1 - SB	14-24	8	25	x	x
S.1 - SB	16-26-36	40			40	
S.1	29-39-59-69	58.5			50	
SB	49-59-69	100			85	

Tab 3	Enclosure type	Size	Minimum surface distance		S.1	SB
			a min.	b+b min.		
	S.1 - SB	14-24	10	32	x	x
S.1 - SB	16-26-36	40			40	
S.1	29-39-59-69	58.5			50	
SB	49-59-69	100			85	

NOTES:  
 Tab 1 for operating voltage U ≤ 400  
 Tab 2 for operating voltage U ≤ 500  
 Tab 3 for operating voltage U ≤ 630

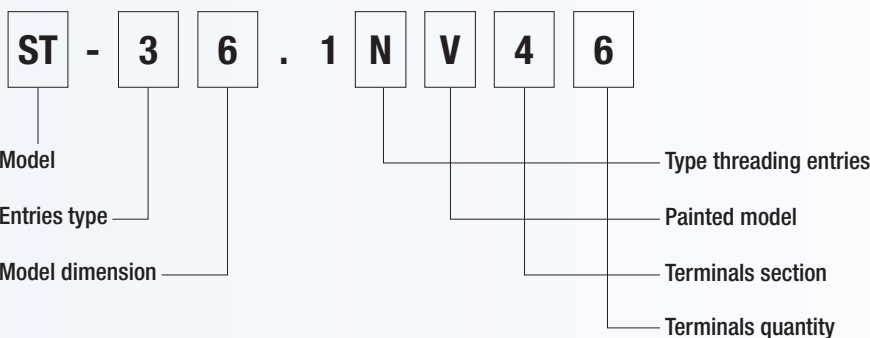


## STANDARD JUNCTION BOX WITH TERMINALS

ILLUSTRATION	DRAWING	DESCRIPTION	CODE
		Junction box type ST-26.1V in aluminium alloy with polyester coating RAL 7035, with n.3 threading holes Ø 3/4", complete with n.3 terminals sect. 2.5sqmm + n.1 earth terminal, numbered 1-2-3-PE.	<b>ST-26.1V24</b> Entries GAS UNI 7/1  <b>ST-26.1NV24</b> Entries NPT
		Junction box type ST-26.1V in aluminium alloy with polyester coating RAL 7035, with n.3 threading holes Ø 3/4", complete with n.5 terminals sect. 4sqmm + n.1 earth terminal, numbered 1-2-3-4-5-PE.	<b>ST-26.1V46</b> Entries GAS UNI 7/1  <b>ST-26.1NV46</b> Entries NPT
		Junction box type ST-36.1V in aluminium alloy with polyester coating RAL 7035, with n.3 threading holes Ø 1", complete with n.5 terminals sect. 2.5sqmm + n.1 earth terminal, numbered 1-2-3-4-5-PE.	<b>ST-36.1V46</b> Entries GAS UNI 7/1  <b>ST-36.1NV46</b> Entries NPT

Label detail mod. ST36.1V46

### Order code logic



Other combinations are available on request (diameters, holes, terminal sections), contact the sales office. For the construction features see page pagina C.2



# ELFIT<sup>®</sup>

Electrical FITtings

## Weather proof series





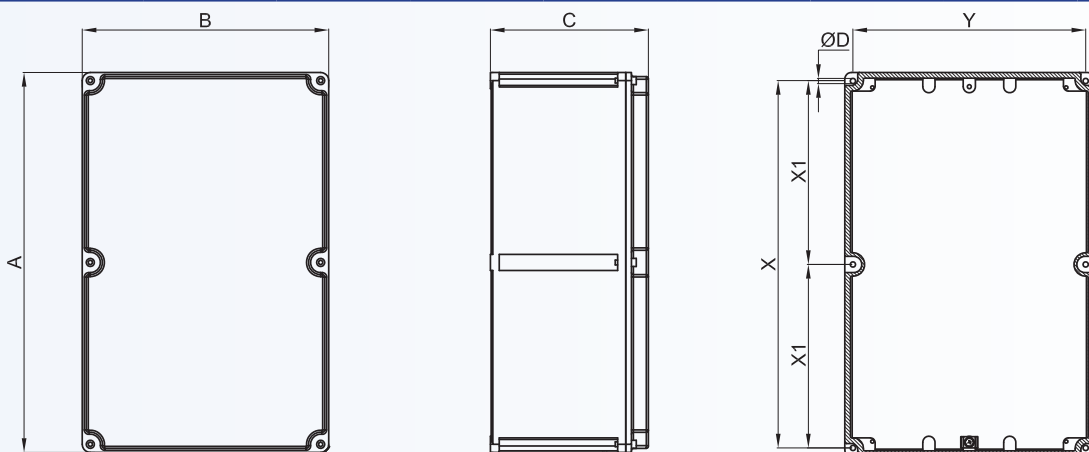
CS... CSG... series junction boxes are made from aluminium alloy and given an electrostatically applied epoxy coating containing stainless steel particles that is then baked at 200°C. This treatment ensures good UV as well as thermal stability, providing mechanical impact resistance and excellent resistance when exposed either to salt mist or to marine and other damp environments. CS and CSG series junction boxes are usually installed in industrial plants and they are mainly used as junction boxes and/or for routing cables to control rooms for analogue or digital signals and for control, monitoring and signalling associated with equipment such as motors, pumps...etc., or for giving physical readings such as flow rate, level, temperature, pressure, etc.... The thickness of its walls (7mm) means the CSG series is suitable for direct connection with pipes and fittings featuring tapered threads. Upon customer's request threaded hubs or bushings, complete with cable glands, plugs and other accessories, can be made.



<b>Standard construction:</b>	Low copper content aluminium alloy. Stainless steel screws and bolts. Silicone gasket. Internal/external earth screws. Fixing lugs. RAL 7035 polyester coating.
<b>Protection degree:</b>	IP 66
<b>Mechanical strenght:</b>	IK10
<b>Standards:</b>	IEC 60529

### ALUMINIUM ENCLOSURES SELECTION CHART

Code	Outside dimensions			Fixing				Weight Kg
	A	B	C	X	Y	X1	ØD	
CS090907	90	90	73	74	74	-	6,5	0,40
CS111108	110	110	83	94	94	-	6,5	0,50
CSG111108	110	110	83	94	94	-	6,5	0,75
CS171108	170	110	83	154	94	-	6,5	0,80
CSG171108	170	110	83	154	94	-	6,5	1,55
CS141410	147	147	100	131	131	-	6,5	0,80
CSG141410	147	147	100	131	131	-	6,5	1,40
CS202012	200	200	120	180	180	-	6,5	1,70
CS301410	305	147	110	285	127	-	6,5	2,00
CSG301410	305	147	110	285	127	-	6,5	2,70
CS302310	305	230	110	285	210	-	6,5	2,80
CSG302310	305	230	100	285	210	-	6,5	3,40
CS302318	305	230	190	285	210	-	6,5	3,50
CSG302318	305	230	190	285	210	-	6,5	5,30
CS473018	475	305	195	450	285	225	6,5	6,50
CSG473018	475	305	195	450	285	225	6,5	8,90
CSG623018	625	305	195	605	285	302,5	6,5	11,3
CSG606018	600	600	205	580	580	290	6,5	27,0



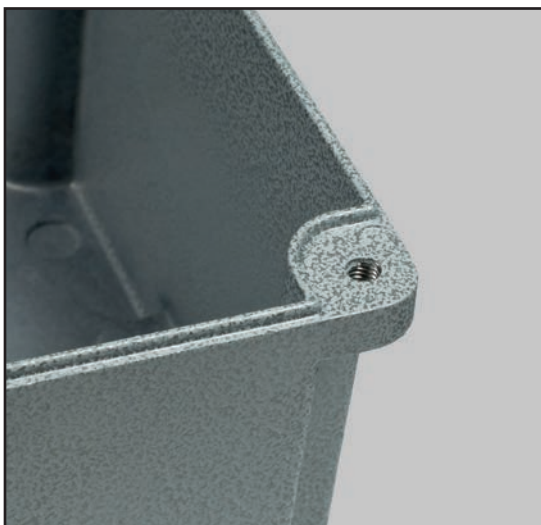
ACCESSORIES UPON REQUEST

ILLUSTRATION	DESCRIPTION	MODEL	SIZE		CODE
			A	B	
	Internal mounting plates  Thickness 25/10 Aluminium  Galvanized steel (B...-229AC)  Stainless steel (B...-229IN)	CS090907	82	48	<b>B09-229</b>
		CSG090907	73	48	<b>B09-229P</b>
		CS111108	100	68	<b>B11-229</b>
		CSG111108	92	68	<b>B11-229P</b>
		CS141410	137	105	<b>B14-229</b>
		CSG141410	129	105	<b>B14-229P</b>
		CS171108	159	67	<b>B17-229</b>
		CS202012	186	146	<b>B20-229</b>
		CS/CSG301410	285	97	<b>B31-229</b>
		CS/CSG302310 CS/CSG302318	285	180	<b>B32-229</b>
		CS/CSG473018	453	254	<b>B43-229</b>
		CS/CSG623018	603	249	<b>B63-229</b>
CSG606018	532	532	<b>B60-229</b>		
ILLUSTRATION	DESCRIPTION	MODEL	CHARACTERISTICS		CODE
	Drain and breather valve	Thread ISO M20 or ISO M25	Material: stainless steel		<b>ECDE-...S</b>
	Entry blanking plugs and cable glands	For models and codes, see cable glands and electrical fittings chapter			
	Hinges (2 per enclosure)	Low lid enclosures	Material: stainless steel		<b>B-0105</b>
		High lid enclosures			<b>B-0106</b>
	Hinges (2 per enclosure)	SAG606018	Material: stainless steel		<b>K-0351</b>

CS and CSG series enclosures

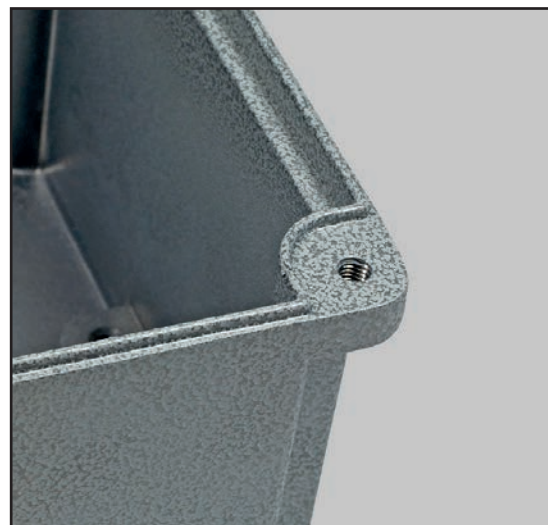
Models from CS...series (lightweight series)  
Thinner walls

The body can only accommodate through holes with no threading



Models from CSG...series (heavy-duty series)  
Extra-thick walls

The body can also accommodate threaded holes





CS/P series junction boxes are made from fibreglass-reinforced polyester. Because they are highly resistant to contamination from fuel oils and mechanical shock, in addition to being lightweight and practical, they can be installed in all industrial plants. The enclosures have special holes made in the base for easy wall mounting.

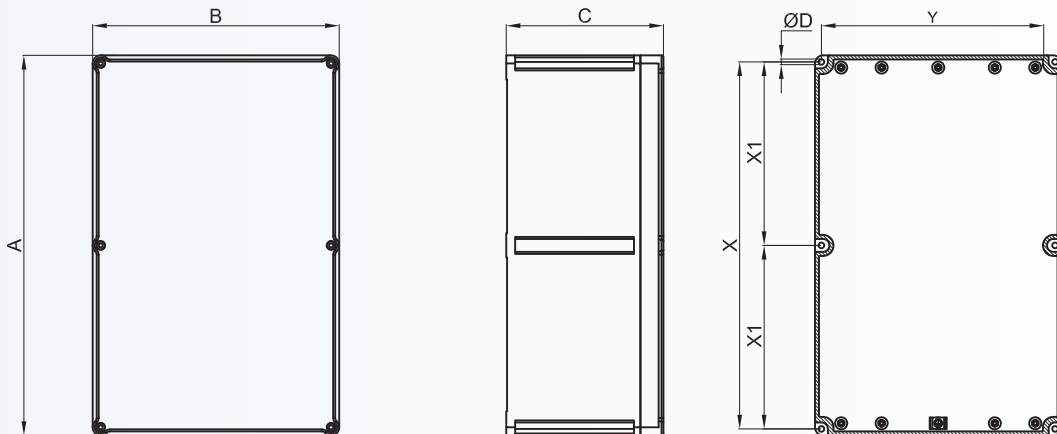
The lid features a silicone gasket that is resistant to low and high temperatures and comes complete with AISI 304 stainless steel screws, which are arranged around the outside of the lid to ensure a tight seal with the IP66 rating. CS/P series enclosures are mainly used as junction boxes for routing cables for analogue or digital signals and/or for control and monitoring associated with equipment such as motors, fans, pumps and/or for giving physical readings such as flow rate, level, pressure, temperature, current, etc..



<b>Standard construction:</b>	GRP (glass reinforced polyester resin) in RAL 9017 black coating. Stainless steel screws and bolts. Silicone gasket. Fixing lugs.
<b>Protection degree:</b>	IP 66
<b>Mechanical strenght:</b>	IK10
<b>Standards:</b>	IEC 60529

### POLYESTER ENCLOSURES SELECTION CHART

Code	Outside dimension			Fixing				Weight Kg
	A	B	C	X	Y	X1	ØD	
CS090907/P	90	90	73	74	74	-	6,5	0,30
CS111108/P	110	110	83	94	94	-	6,5	0,40
CS171108/P	170	110	83	154	94	-	6,5	0,80
CS141410/P	147	147	100	131	131	-	6,5	1,00
CS301410/P	305	147	110	285	127	-	6,5	1,90
CS302310/P	305	230	110	285	210	-	6,5	2,50
CS302318/P	305	230	190	285	210	-	6,5	3,10
CS473018/P	470	305	195	450	285	225	6,5	4,70
CS623018/P	620	305	185	560	285	260-300	8	6,30



**ACCESSORIES UPON REQUEST**

ILLUSTRATION	DESCRIPTION	MODEL	SIZE		CODE
			A	B	
	Internal mounting plates  Thickness 2.5mm Aluminium  Galvanized steel (B...-229AC)  Stainless steel (B...-229IN)	CS090907/P	82	48	<b>B09-229</b>
		CS111108/P	100	68	<b>B11-229</b>
		CS141410/P	137	105	<b>B14-229</b>
		CS171108/P	159	67	<b>B17-229</b>
		CS301410/P	285	97	<b>B31-229</b>
		CS302310/P CS302318/P	285	180	<b>B32-229</b>
		CS473018/P CS623018/P	453 603	254 249	<b>B43-229</b> <b>B63-229</b>
ILLUSTRATION	DESCRIPTION	MODEL	CHARACTERISTICS		CODE
	Drain and breather valve	Thread ISO M20 or ISO M25	Material: stainless steel		<b>ECDE-...S</b>
	Entry blanking plugs and cable glands	For models and codes, see cable glands and electrical fittings chapter			
	Hinges (2 per enclosure)	Low lid enclosures	Material: stainless steel		<b>B-0105</b>
		High lid enclosures			<b>B-0106</b>
	Through earth connection	M8	Material: stainless steel		<b>K-0307/1</b>
		M6			<b>K-0307/2</b>
	Brass continuity plates for earthing	For models and codes see the following scheme			<b>B-...</b>

**CONTINUITY PLATES**

Enclosure	Plate code	Plate code	
		Long side	Short side
CS090907/P	B-388	B-455	
CS111108/P	B-389	B-456	
CS141410/P	B-390	B-457	
CS171108/P	B-391	B-458	B-456
CS301410/P	B-392	B-459	B-457
CS302310/P	B-393	B-459	B-460
CS302318/P	B-394	B-461	B-462
CS473018/P	B-395	(2x) B-462	B-461
CS623018/P	-	(2x) B-463	B-463



CS/SS series watertight junction boxes, in stainless steel, are suitable for containing any electrical and electronic equipment. Thanks to the material used and their features, they are particularly indicated for industrial environments with strongly aggressive atmospheres.

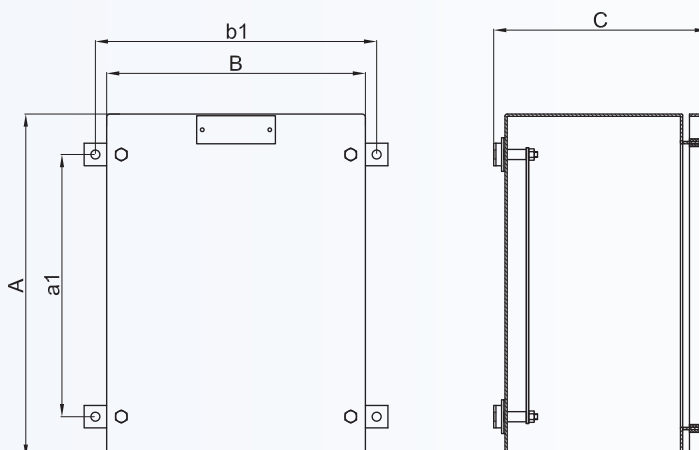


<b>Standard construction:</b>	Stainless steel AISI 316L Stainless steel bolts and screws Silicone gasket Fixing lugs
<b>Protection degree:</b>	IP 66
<b>Mechanical strenght:</b>	IK10
<b>Standards:</b>	IEC 60529




### STAINLESS STEEL ENCLOSURES SELECTION CHART

Codice	External dimensions			Fixing		Weight Kg
	A	B	C	a1	b1	
CS111108SS	110	110	90	38	130	0,80
CS141410SS	147	147	110	75	167	1,40
CS171108SS	170	110	90	98	130	1,20
CS301410SS	305	147	110	233	167	2,50
CS302310SS	305	230	110	233	250	4,30
CS302318SS	305	230	190	233	250	5,60
CS404020SS	400	400	210	328	420	10,90
CS473018SS	470	305	190	398	325	8,00
CS623018SS	620	305	190	548	325	12,00
CS606020SS	600	600	210	528	620	16,00

Other dimensions can be enquired.



**ACCESSORIES UPON REQUEST**

ILLUSTRATION	DESCRIPTION	MODEL	SIZE		CODE
			A	B	
	Internal mounting plates Stainless steel	CS111108SS	50	50	<b>B11-357</b>
		CS141410SS	87	87	<b>B14-357</b>
		CS171108SS	110	50	<b>B17-357</b>
		CS301410SS	245	87	<b>B301-357</b>
		CS302310SS CS302318SS	245	170	<b>B302-357</b>
		CS404020SS	340	340	<b>B40-357</b>
		CS473018SS	410	245	<b>B47-357</b>
		CS623018SS CS606020SS	560 540	245 540	<b>B62-357</b> <b>B603-357</b>
ILLUSTRATION	DESCRIPTION	MODEL	CHARACTERISTICS		CODE
	Drain and breather valve	Thread ISO M20 or ISO M25	Material: stainless steel		<b>ECDE-...S</b>
	Entry blanking plugs and cable glands	For models and codes, see cable glands and electrical fittings chapter			

**SPECIAL REQUEST**

- CS-...SSF...** Junction box with walls with gland plates
- CS-...SSC...** Junction box with cover fixing by lock system
- CS-...SSCF...** Junction box with walls with gland plates and cover fixing by lock system

**LOCK SYSTEM**

**Code example**

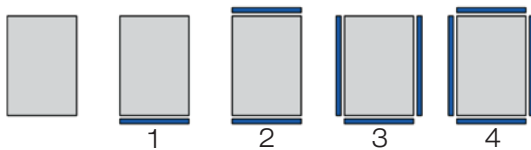
**1) CS302318SSC**

Stainless steel junction box 305x230x190 with cover fixing by lock system



**CS...SSF.. SERIES ENCLOSURES WITH REMOVABLE GLAND PLATES**

Removable gland plate position coding



**Code example**

**1) CS302318SSF3**

Stainless steel junction box 305x230x190 with 3 removable gland plates

**2) CS473018SSF1**

Stainless steel junction box 470x305x190 with 1 removable gland plate

Code	SIZE REMOVABLE GLAND PLATES			
	Side A	Side B	Side C	Side D
<b>CS302318SSF..</b>	130x100	225x100	150x100	225x100
<b>CS404020SSF..</b>	300x120	320x120	320x120	320x120
<b>CS473018SSF..</b>	205x100	390x100	225x100	390x100
<b>CS623018SSF..</b>	205x100	540x100	225x100	540x100
<b>CS606020SSF..</b>	500x120	520x120	520x120	520x120



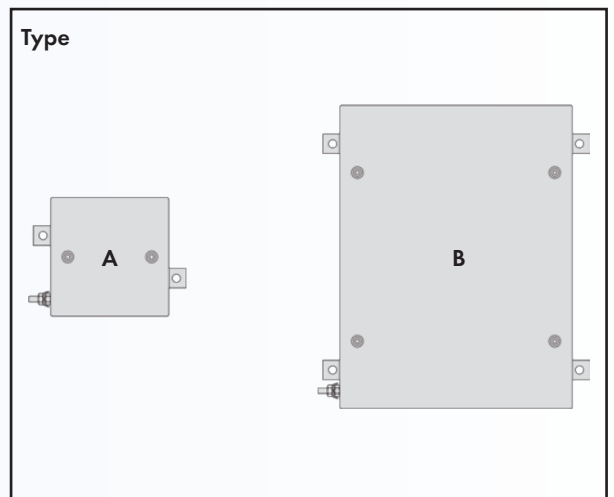
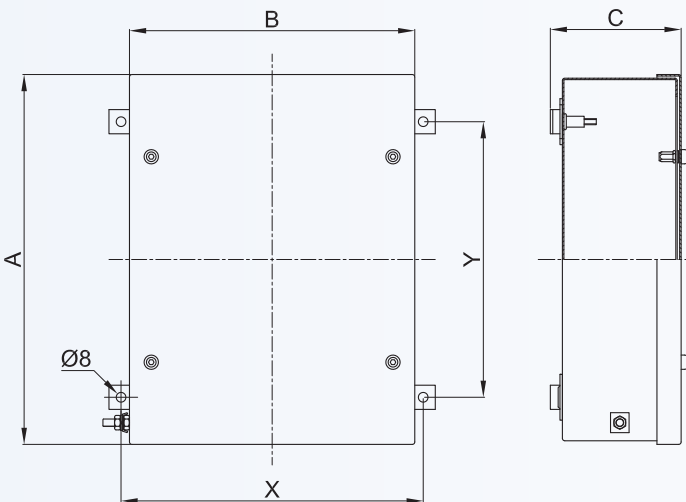
Economic junction boxes, are used as pulling or junction boxes in areas where there is no danger of explosion, but it is required a specific protection to prevent the entry of solids and liquids. They are stainless steel made and can be installed in chemical and off-shore plants and where is a strong external agents'aggression. Upon specific request they can be supplied with terminal blocks and copper rods for earth connections. Upon customer request threaded hubs or bushings, complete with cable glands, plugs and other accessories both on the enclosure's side and on specific removable flanges, can be made.






<b>Standard construction:</b>	Stainless steel AISI 316L Stainless steel bolts and screws Silicone gasket Fixing lugs
<b>Degree of protection:</b>	IP 66
<b>Mechanical strenght:</b>	IK 10
<b>Standards:</b>	IEC 60529

### STAINLESS STEEL ENCLOSURES SELECTION CHART

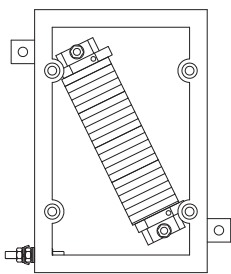
Code	Outside dimensions			Fixing		ØD	Weight Kg
	A	B	C	X	Y		
CTBEW121208	120	120	90	135	42	A	
CTBEW151208	150	120	90	135	73	A	
CTBEW151509	150	150	100	165	73	A	
CTBEW191509	190	150	100	165	113	A	
CTBEW191910	190	190	100	165	73	A	
CTBEW221513	229	152	140	205	113	A	
CTBEW262610	258	258	110	273	181	B	
CTBEW262616	258	258	170	273	181	B	
CTBEW262620	258	258	210	273	181	B	
CTBEW301410	306	146	110	160	228	B	
CTBEW302310	306	236	110	250	228	B	
CTBEW303010	306	306	110	320	228	B	
CTBEW303016	306	306	170	320	228	B	
CTBEW303020	306	306	210	320	228	B	
CTBEW381612	380	160	130	175	303	B	
CTBEW382610	380	260	110	275	303	B	
CTBEW382616	380	260	170	275	303	B	
CTBEW382620	380	260	210	275	303	B	
CTBEW402513	400	250	140	265	323	B	



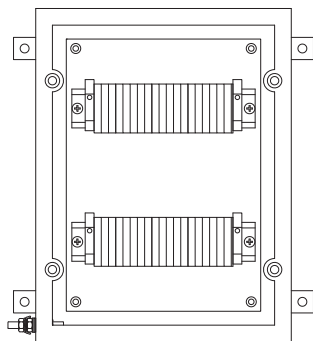
ACCESSORIES UPON REQUEST

ILLUSTRATION	DESCRIPTION	MODEL	SIZE		CODE
			A	B	
	Internal mounting plates Stainless steel	CTBEW121208	60	60	<b>B12-484</b>
		CTBEW151509	90	90	<b>B15-484</b>
		CTBEW191910	130	130	<b>B19-484</b>
		CTBEW221513	170	90	<b>B22-484</b>
		CTBEW262610 CTBEW262616 CTBEW262620	200	200	<b>B26-484</b>
		CTBEW301410	245	85	<b>B303-484</b>
		CTBEW302310	145	175	<b>B302-484</b>
		CTBEW303010 CTBEW303016 CTBEW303020	245	245	<b>B30-484</b>
		CTBEW382610 CTBEW382616 CTBEW382620	320	200	<b>B38-484</b>
ILLUSTRATION	DESCRIPTION	MODEL	CHARACTERISTICS		CODE
	Entry blanking plugs and cable glands		For models and codes, see cable glands and electrical fittings chapter		
	Drain and breather valve	Thread ISO M20 or ISO M25	Material: stainless steel		<b>ECDE-...S</b>

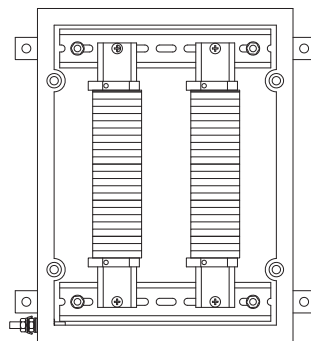
INSTALLATION EXAMPLE OF INSIDE TERMINAL BLOCKS



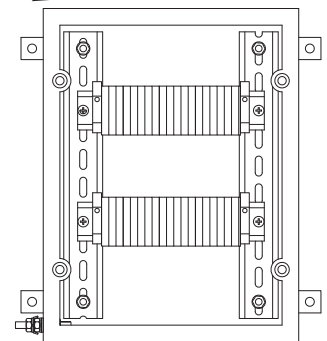
Diagonally and directly installed on internal inserts for greater amount of terminal blocks on small enclosures



Horizontally or vertically, installed on mounting plate in order to minimize oscillations of terminal block in case of external vibrations



Vertically installed on DIN guides for greater cheapness



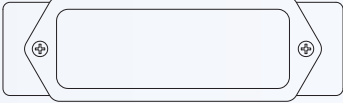


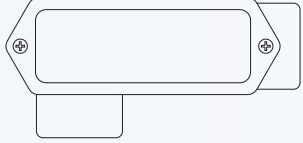
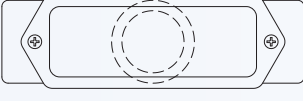
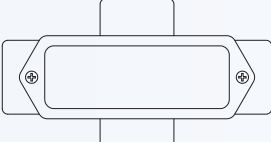
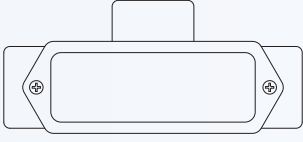
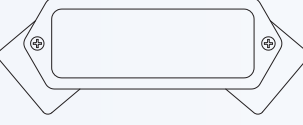
Horizontally installed on DIN guides for greater cheapness

## 7 series pulling boxes (CONDULET)

Condulet are used as pulling or junction boxes in areas where there is no danger of explosion, but it is required a specific protection to prevent the entry of solids and liquids. They are aluminium made and can be installed in chemical and off-shore plants and where there is a strong external agents aggression.

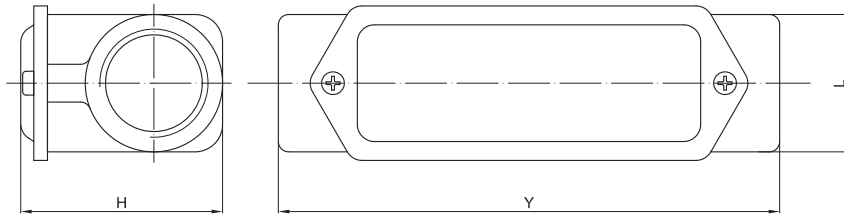
<b>Standard construction:</b>	Body and cover in aluminium alloy Galvanized steel bolts and screws Elastomer gasket
<b>Degree of protection</b>	IP 65
<b>Standards:</b>	IEC 60529
<b>On request:</b>	Other threads: (For example NPT thread: LL27N) Coating Stainless steel screws



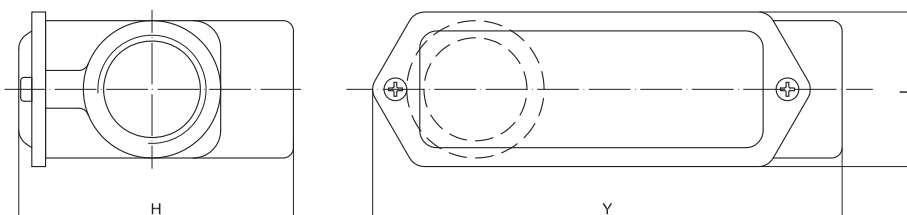
Box type	Code	Description
	C	Enclosure with two coaxial hubs
	LB	Enclosure with two hubs arranged at 90° (One hub arranged on the bottom of the enclosure)
	LL	Enclosure with two hubs arranged at 90° (One hub arranged on the bottom left side)
	LR	Enclosure with two hubs arranged at 90° (One hub arranged on the right side)
	TB	Enclosure with three hubs, two coaxial and one at 90° arranged on the middle of the enclosure's bottom
	X	Enclosure with four cross hubs
	T	Enclosure with three hubs, two coaxial and one at 90° arranged on the side
	LU	Enclosure with two 45° hubs with respect to the axis



PULLING BOXES SELECTION CHART					
Box type	Thread	Dimensions in mm			Weight Kg
		Y	L	H	
C17	1/2" IS0228/1	118	51	42	0,168
C27	3/4" IS0228/1	123	40	48	0,151
C37	1" IS0228/1	146	45	57	0,234
C47	1 ¼" IS0228/1	171	62	71	0,417
C57	1 ½" IS0228/1	171	62	71	0,372
C67	2" IS0228/1	204	76	83	0,514
C77	2 ½" IS0228/1	315	108	125	1,779
C87	3" IS0228/1	315	108	125	1,779
C107	4" IS0228/1	314	133	148	2,606



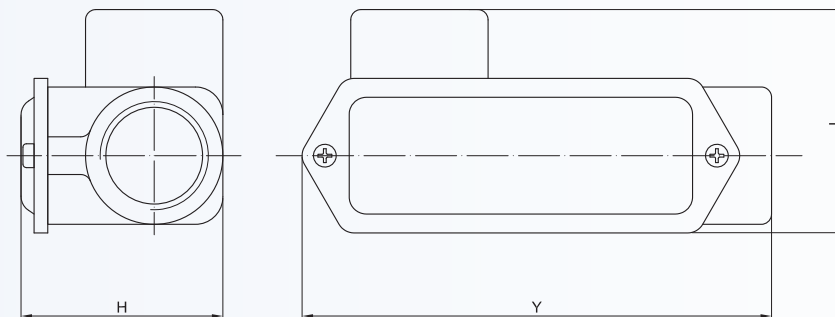
PULLING BOXES SELECTION CHART					
Box type	Thread	Dimensions in mm			Weight Kg
		Y	L	H	
LB17	1/2" IS0228/1	117	40	65	0,172
LB27	3/4" IS0228/1	117	40	65	0,159
LB37	1" IS0228/1	137	45	78	0,236
LB47	1 ¼" IS0228/1	163	62	89	0,427
LB57	1 ½" IS0228/1	163	62	89	0,387
LB67	2" IS0228/1	190	76	108	0,541
LB77	2 ½" IS0228/1	238	107	150	2,121
LB87	3" IS0228/1	238	107	150	1,785
LB107	4" IS0228/1	300	133	185	2,658



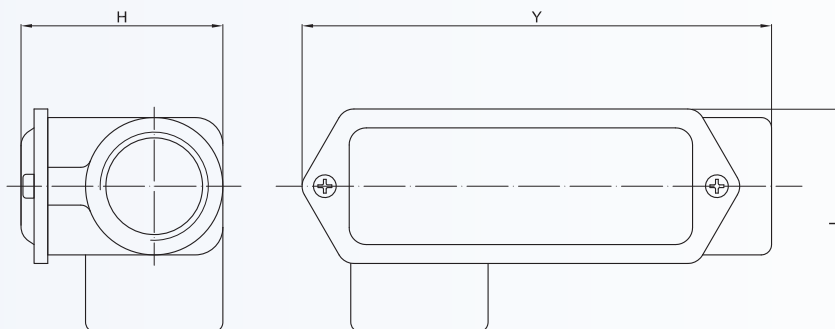




PULLING BOXES SELECTION CHART					
Box type	Thread	Dimensions in mm			Weight Kg
		Y	L	H	
LL17	1/2" ISO228/1	117	51	48	0,171
LL27	3/4" ISO228/1	117	51	48	0,150
LL37	1" ISO228/1	137	61	57	0,238
LL47	1 1/4" ISO228/1	163	76	71	0,414
LL57	1 1/2" ISO228/1	163	76	71	0,381
LL67	2" ISO228/1	190	94	83	0,522
LL77	2 1/2" ISO228/1	238	138	122	2,084
LL87	3" ISO228/1	238	138	122	1,748
LL107	4" ISO228/1	300	162	148	2,666

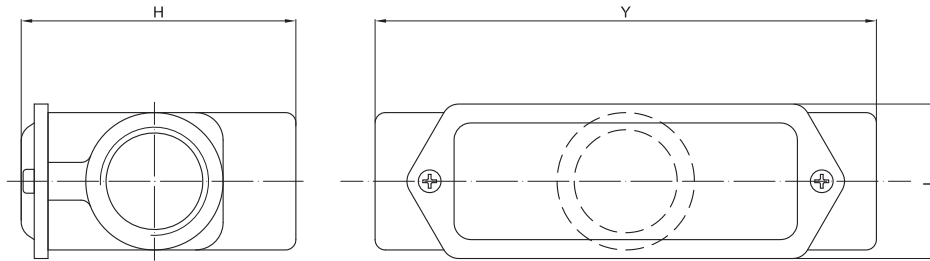


PULLING BOXES SELECTION CHART					
Box type	Thread	Dimensions in mm			Weight Kg
		Y	L	H	
LR17	1/2" ISO228/1	117	51	48	0,171
LR27	3/4" ISO228/1	117	51	48	0,150
LR37	1" ISO228/1	137	61	57	0,238
LR47	1 1/4" ISO228/1	163	76	71	0,414
LR57	1 1/2" ISO228/1	163	76	71	0,381
LR67	2" ISO228/1	190	94	83	0,522
LR77	2 1/2" ISO228/1	238	138	122	2,084
LR87	3" ISO228/1	238	138	122	1,748
LR107	4" ISO228/1	300	162	148	2,666

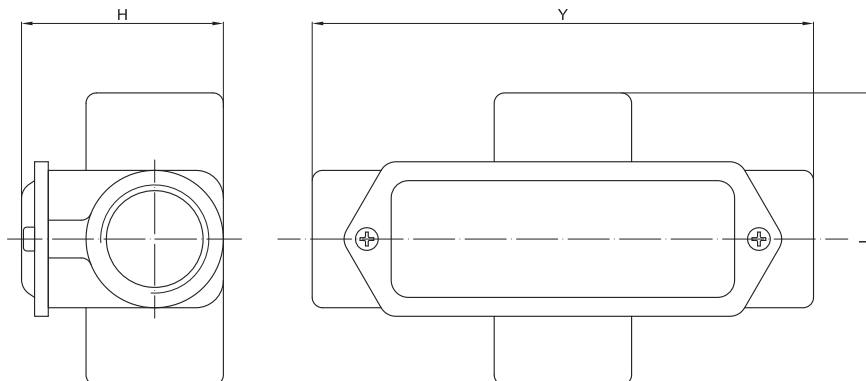




PULLING BOXES SELECTION CHART					
Box type	Thread	Dimensions in mm			Weight Kg
		Y	L	H	
TB17	1/2" IS0228/1	123	40	65	0,193
TB27	3/4" IS0228/1	123	40	65	0,168
TB37	1" IS0228/1	146	45	78	0,254
TB47	1 ¼" IS0228/1	171	62	89	0,488
TB57	1 ½" IS0228/1	171	62	89	0,416
TB67	2" IS0228/1	204	76	108	0,607
TB77	2 ½" IS0228/1	315	108	163	2,492
TB87	3" IS0228/1	315	108	163	1,996
TB107	4" IS0228/1	314	133	185	2,747



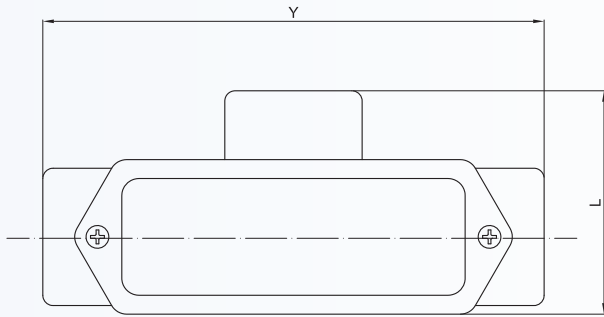
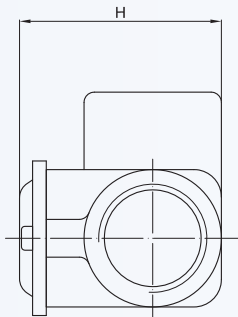
PULLING BOXES SELECTION CHART					
Box type	Thread	Dimensions in mm			Weight Kg
		Y	L	H	
X17	1/2" IS0228/1	123	68	48	0,217
X27	3/4" IS0228/1	123	68	48	0,187
X37	1" IS0228/1	146	81	57	0,289
X47	1 ¼" IS0228/1	171	96	71	0,532
X57	1 ½" IS0228/1	171	96	71	0,428
X67	2" IS0228/1	204	118	83	0,623
X77	2 ½" IS0228/1	315	183	125	2,394
X87	3" IS0228/1	315	183	125	2,105
X107	4" IS0228/1	315	196	148	2,881



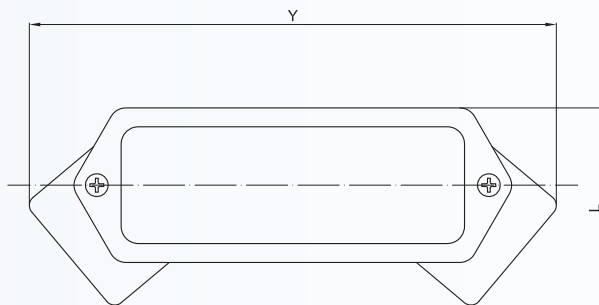
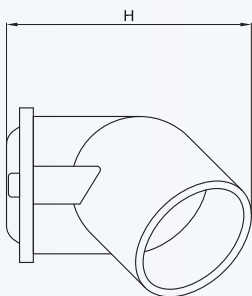
**7 series pulling boxes (CONDULET)**

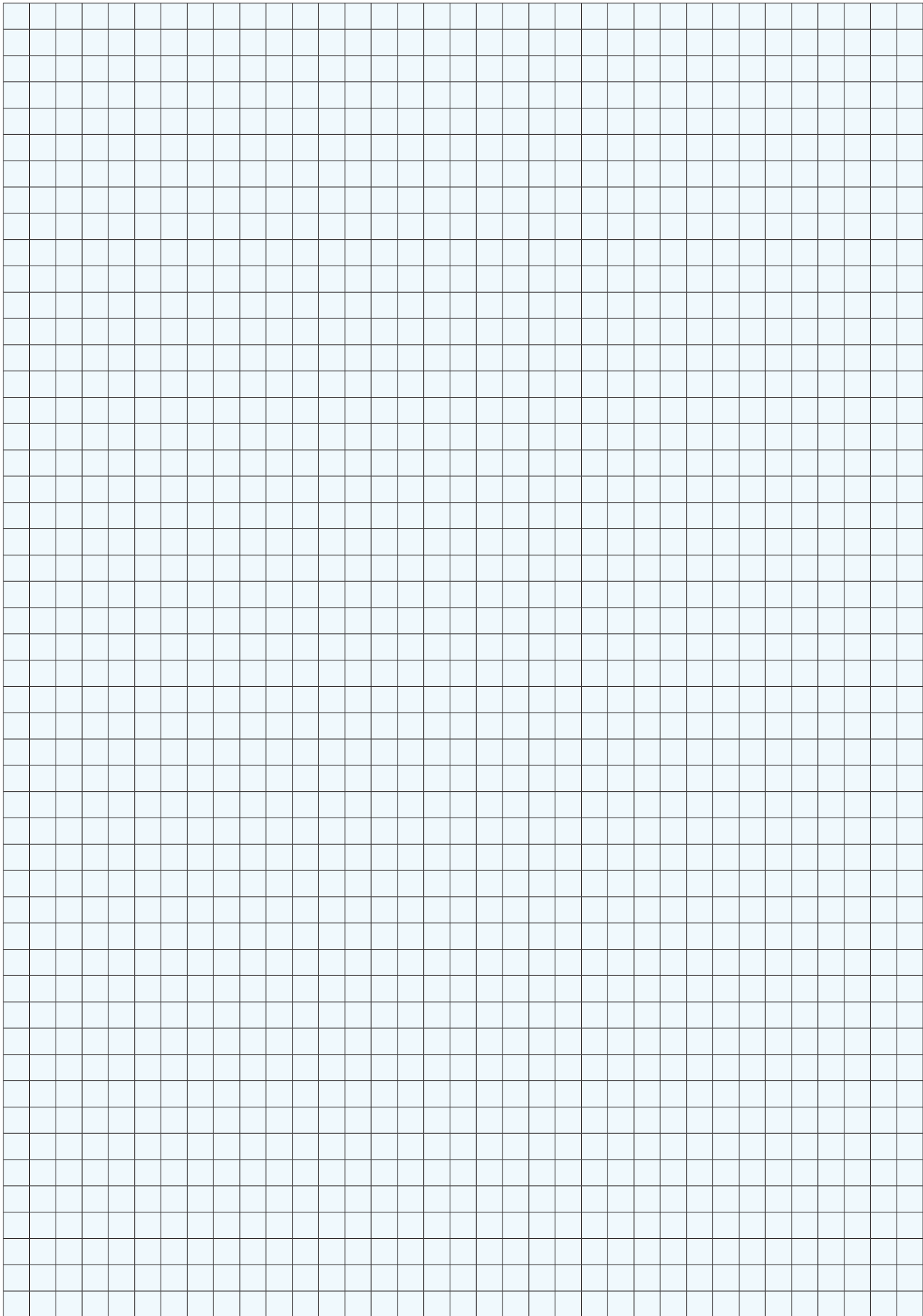


PULLING BOXES SELECTION CHART					
Box type	Thread	Dimensions in mm			Weight Kg
		Y	L	H	
T17	1/2" ISO228/1	123	53	48	0,191
T27	3/4" ISO228/1	123	53	48	0,170
T37	1" ISO228/1	146	63	57	0,264
T47	1 1/4" ISO228/1	171	78	71	0,473
T57	1 1/2" ISO228/1	171	78	71	0,410
T67	2" ISO228/1	204	96	83	0,560
T77	2 1/2" ISO228/1	315	148	125	2,457
T87	3" ISO228/1	315	148	125	1,948
T107	4" ISO228/1	315	166	148	2,725



PULLING BOXES SELECTION CHART					
Box type	Thread	Dimensions in mm			Weight Kg
		Y	L	H	
LU17	1/2" ISO228/1	130	64	44	0,185
LU27	3/4" ISO228/1	130	64	44	0,167
LU37	1" ISO228/1	148	73	50	0,217
LU47	1 1/4" ISO228/1	182	103	71	0,523
LU57	1 1/2" ISO228/1	182	103	71	0,456
LU67	2" ISO228/1	211	118	83	0,639
LU77	2 1/2" ISO228/1	310	156	115	2,498
LU87	3" ISO228/1	310	156	115	1,961







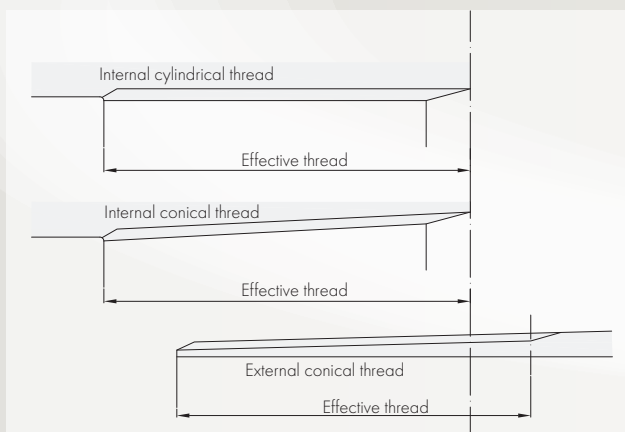
# Appendix

## TABLE OF THREAD CORRELATION

Hub size	"M" and "F" thread hub diameter					
	GAS UNI ISO 7/1	Conical equivalent	Cylindrical equivalent			
		NPT ANSI ASME B1.20.1	GAS UNI ISO 228/1	NPSM	PG DIN 4030	ISO METRIC
1/4"	1/4"	1/4"	1/4"	1/4"	PG9	M12x1,5
<b>Code</b>	<b>02</b>	<b>02N</b>	<b>02C</b>	<b>02NC</b>	<b>2P</b>	<b>02I</b>
3/8"	3/8"	3/8"	3/8"	3/8"	PG11	M16x1,5
<b>Code</b>	<b>01</b>	<b>01N</b>	<b>01C</b>	<b>01NC</b>	<b>3P</b>	<b>01I</b>
1/2"	1/2"	1/2"	1/2"	1/2"	PG13,5	M20x1,5
<b>Code</b>	<b>1</b>	<b>1N</b>	<b>1C</b>	<b>1NC</b>	<b>4P</b>	<b>1I</b>
3/4"	3/4"	3/4"	3/4"	3/4"	PG16	M25x1,5
<b>Code</b>	<b>2</b>	<b>2N</b>	<b>2C</b>	<b>2NC</b>	<b>5P</b>	<b>2I</b>
1"	1"	1"	1"	1"	PG21	M32x1,5
<b>Code</b>	<b>3</b>	<b>3N</b>	<b>3C</b>	<b>3NC</b>	<b>6P</b>	<b>3I</b>
1 1/4"	1 1/4"	1 1/4"	1 1/4"	1 1/4"	PG29	M40x1,5
<b>Code</b>	<b>4</b>	<b>4N</b>	<b>4C</b>	<b>4NC</b>	<b>7P</b>	<b>4I</b>
1 1/2"	1 1/2"	1 1/2"	1 1/2"	1 1/2"	PG36	M50x1,5
<b>Code</b>	<b>5</b>	<b>5N</b>	<b>5C</b>	<b>5NC</b>	<b>8P</b>	<b>5I</b>
2"	2"	2"	2"	2"	PG42	M63x1,5
<b>Code</b>	<b>6</b>	<b>6N</b>	<b>6C</b>	<b>6NC</b>	<b>9P</b>	<b>6I</b>
2 1/2"	2 1/2"	2 1/2"	2 1/2"	2 1/2"	PG48	M75x1,5
<b>Code</b>	<b>7</b>	<b>7N</b>	<b>7C</b>	<b>7NC</b>	<b>10P</b>	<b>7I</b>
3"	3"	3"	3"	3"	-	M90x1,5
<b>Code</b>	<b>8</b>	<b>8N</b>	<b>8C</b>	<b>8NC</b>	-	<b>8I</b>
4"	4"	4"	4"	4"	-	M100x1,5
<b>Code</b>	<b>10</b>	<b>10N</b>	<b>10C</b>	<b>10NC</b>	-	<b>10I</b>

## THREADS SIZE (in mm)

GAS UNI ISO 7/1 Thread											
Size	1/4"	3/8"	1/2"	3/4"	1"	1 1/4"	1 1/2"	2"	2 1/2"	3"	4"
Pitch	1,337	1,337	1,814	1,814	2,309	2,309	2,309	2,309	2,309	2,309	2,309
Ø external	13,157	16,662	20,955	26,441	33,249	41,910	47,803	59,614	75,184	87,884	113,030



Example of indication in accordance with UNI ISO 7/1  
Example with thread from 1 1/4"

Internal thread	Conical	UNI ISO 7/1 - Rc 1 1/4"
	Cylindrical	UNI ISO 7/1 - Rp 1 1/4"
External thread	Always conical	UNI ISO 7/1 - R 1 1/4"

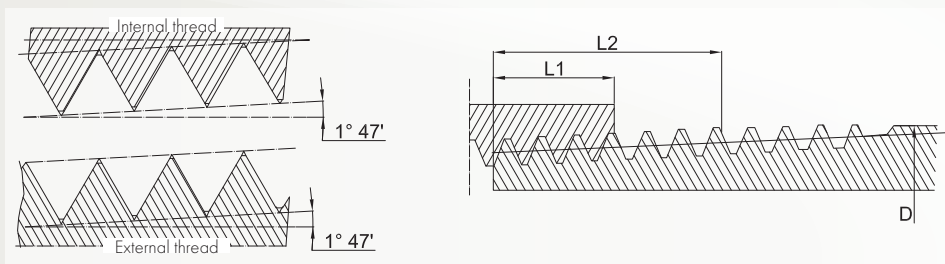
Key:

Rp UNI ISO 7/1 internal cylindrical thread

Rc UNI ISO 7/1 internal conical thread

R UNI ISO 7/1 external thread (always conical)

NPT Thread - American standard ANSI B1.20.1											
Size	1/4"	3/8"	1/2"	3/4"	1"	1 1/4"	1 1/2"	2"	2 1/2"	3"	4"
Pitch	1,411	1,411	1,814	1,814	2,208	2,208	2,208	2,208	3,175	3,175	3,175
Threads per inch	18	18	14	14	11,5	11,5	11,5	11,5	8	8	8
External D (of pipe)	13,716	17,145	21,336	26,670	33,401	42,164	48,260	60,325	73,025	88,90	114,30
Effective thread L2	10,206	10,358	13,556	13,861	17,343	17,953	18,377	19,215	28,892	30,480	33,020
Handtight Engagement L1	5,786	6,096	8,128	8,611	10,160	10,668	10,668	11,074	17,323	19,456	21,438



GAS UNI ISO 228/1 Thread											
Size	1/4"	3/8"	1/2"	3/4"	1"	1 1/4"	1 1/2"	2"	2 1/2"	3"	4"
Pitch	1,34	1,34	1,81	1,81	2,31	2,31	2,31	2,31	2,31	2,31	2,31
Threads per inch	19	19	14	14	11	11	11	11	11	11	11
Ø external	13,16	16,66	20,96	26,44	33,25	41,91	47,80	59,61	75,18	87,88	113,03

NPSM Thread											
Size	1/4"	3/8"	1/2"	3/4"	1"	1 1/4"	1 1/2"	2"	2 1/2"	3"	4"
Pitch	1,411	1,411	1,814	1,814	2,209	2,209	2,209	2,209	3,175	3,175	3,175
Threads per inch	18	18	14	14	11,5	11,5	11,5	11,5	8	8	8
Ø external	13,716	17,145	21,336	26,670	33,401	42,164	48,260	60,325	73,025	88,900	114,30

PG DIN 4030 Thread										
Size	PG9	PG11	PG13,5	PG16	PG21	PG29	PG36	PG42	PG48	
Pitch	1,410	1,410	1,410	1,410	1,588	1,588	1,588	1,588	1,588	
Threads per inch	18	18	18	18	16	16	16	16	16	
Ø external	15,2	18,6	20,4	22,5	28,3	37,0	47,0	54,0	59,3	

ISO METRIC Thread											
Size	M12	M16	M20	M25	M32	M40	M50	M63	M75	M90	M100
Pitch	1,5	1,5	1,5	1,5	1,5	1,5	1,5	1,5	1,5	1,5	1,5
Ø external	12	16	20	25	32	40	50	63	75	90	100

# Appendix

## EXPLOSION-PROOF OR WEATHER-PROOF EQUIPMENT

Very often, the explosion-proof equipment is confused with water-proof equipment, even in technical environments. This comes from the incorrect belief that it's possible to avoid an explosion preventing an explosive atmosphere to get in touch with the ignition source (spark, arc or hot spot).

This may be partially true if the hazardous substance is a powder suspended in the air, but it's a misconception if the explosive atmosphere is represented by a gas.

This belief may cause an improper use of an enclosure, incorrectly considered as water-proof, in unsuitable conditions to ensure their safety.

To analyse properly the problem, we need to step back and understand what are the principles on which is based the electrical explosion protection.

The principles are three:

- Containment
- Segregation
- Prevention

### • Containment

'Ex d' method of protection is based on the principle that it's not possible to absolutely prevent a gas from entering into an enclosure.

This is the oldest method of protection, but still today the one that is most commonly used and, consequently, the 'Ex d' products are the most common on the market.

The majority of applications for conventional power plant can be achieved with this type of protection.

### • Segregation

This principle prevents the explosive atmosphere from coming into contact with an ignition source. Different systems are used: the immersion of the equipment in oil, sand or resin. These systems, respectively 'Ex o', 'Ex q', 'Ex m', are primarily used to protect electrical components.

### • Prevention

The protection is provided through the over sizing of the equipment that prevents the creation of sparks or electric arcs, even under fault conditions.

These systems ('Ex e', 'Ex i') are used respectively for junction and pulling systems or they are applicable in the case of intrinsically safe instrumentation or to other equipment that operate at very low powers. Nobody would ever think to build an electric panel of a refinery through an intrinsically safe system.

'Ex e' method of protection, the increased safety, is usable alone only for those equipment that, of course, cannot sparkle such as the junction boxes with terminals. But if the system contains equipment that can sparkle, they must be individually protected with another type of protection.




## HAZARDOUS AREAS CLASSIFICATION

Only highly qualified staff should identify and classify hazardous areas in a chemical or petrochemical plant, who decide where there is a permanently or occasionally explosive atmosphere in the plant.

The most hazardous areas are where combustible gas or dusts may be present during normal operation or due to a fault. The classification is based on what type of combustible gas or dust is present in a specific area.




Nevertheless, it is important to underline that there is no uniformity in the classification of hazardous area, so below we have listed European classification, which correspond with international IEC and American categories.

## GAS

		<b>Zone 0</b>	Area in which an explosive atmosphere, consisting in a mixture of air and flammable substances in the shape of gas, vapor or mist, is present permanently or for long periods or often.	<b>Zone 1</b>	Area in which during normal activities the formation of an explosive atmosphere consisting in a mixture of air and flammable substances in the shape of gas, vapor or mist, is possible.	<b>Zone 2</b>	Area in which during normal activities the formation of an explosive atmosphere consisting in a mixture of air and flammable substances in the shape of gas, vapor or mist, is not possible, and in case it happens, it lasts very shortly.
	<b>NEC 500</b>	<b>Class I, Division 1</b>				<b>Class I, Division 2</b>	
	<b>NEC 505</b>	<b>Class I, Zone 0</b>		<b>Class I, Zone 1</b>		<b>Class I, Zone 2</b>	

Tab. 1 Comparison between hazardous areas classification for presence of gas based on international standards (IEC Zone System) and according to North American standards

## DUSTS

		<b>Zone 20</b>	Area in which an explosive atmosphere is present permanently or for long periods or often, in the shape of clouds of dusts.	<b>Zone 21</b>	Area in which occasionally during normal activities the formation of an explosive atmosphere in the shape of cloud of combustible dust in the air, is possible.	<b>Zone 22</b>	Area in which during normal activities the formation of an explosive atmosphere in the shape of cloud of combustible dust is not possible, and in case it happens, it lasts very shortly.
	<b>NEC 500</b>	<b>Class II, Division 1</b>				<b>Class II, Division 2</b>	
	<b>NEC 505</b>	<b>Class II, Zone 20</b>		<b>Class II, Zone 21</b>		<b>Class II, Zone 22</b>	

Tab. 2 Comparison between hazardous areas classification for presence of dusts based on international standards (IEC Zone System) and according to North-American standards

## Groups and categories, EPL (Equipment Protection Level)

The 2014/34/UE Directive foresees the following division:

- Group I: products addressed to mines and in their surface systems, where firedamp gas can be present.
- Group II: products addressed to surface sites with the presence of explosive atmosphere.

The products are then divided inside the Groups as follows:

Group I

- category M1: equipment which guarantees a very high protection level; it has to be kept powered in presence of explosive atmosphere.
- category M2: equipment which guarantees a very high protection level; it must be possible to cut the power off in presence of explosive atmosphere.



# Appendix

## Group II

- **category 1:** equipment which guarantees a very high protection level; it is intended to be used in areas in which there is, always or for long periods, the presence of explosive atmosphere.
- **category 2:** equipment which guarantees a very high protection level; it is intended to be used in areas in which the development of explosive atmosphere is most likely.
- **category 3:** equipment which guarantees a normal protection level; it is intended to be used in areas in which the development of explosive atmosphere is slightly possible.

The numbers of the categories of group II (1, 2, 3) are followed by a capital letter:

- G, for gases;
- D, for combustible dusts.

For example: II 2G.

On the basis of group II definitions and by comparing them to those provided by the 99/92/CE "ATEX 137" Directive, a two-way link is established and highlighted in Table 9, between equipment category and installation area.

What we have described above is valid for the EU.

Outside EU, until 2007, the equipment was marked only with the protection method.

Therefore, inspired by the European system, the EPL Equipment Protection Level (Table 10) has been created, replacing the letters "a", "b", "c" to the numbers "1", "2" and "3".

Currently, at a technical standard level, the group III related only to dusts, has been divided in three sub-categories, similarly to what it has already done for gas.

The subgroups are:

- IIIA: flammable particles; solid particles, fibers included, with nominal sizes > 500 µm;
- IIIB: non-conductive dust; finely divided solid particles, with nominal sizes ≤ 500 µm, with electrical resistivity > 103 Ωm;
- IIIC: conductive dust; finely divided solid particles, with nominal sizes ≤ 500 µm, with electrical resistivity ≤ 103 Ωm.

As described above, the "Ex d" protection method is highly probably the oldest protection method and its applicability to multiple types of industrial products has allowed its great spread.

Comparing a normal equipment to an "Ex d" one, the first evident characteristic is the strength of the latter, since it has to resist mechanically, without being deformed plastically, to the internal pressure generated by the explosion. The pressure ranges normally from 5 to 12 bar. Therefore, in this method, which is the only one based on the explosion containment (held at pressure), the protection is given by the junction box.

The sparking electrical components are enclosed inside the junction box, that allows the explosive atmosphere to enter but, in case of contact between this and the ignition source (arc or spark) the consequent explosion remains confined inside the junction box. Through the flame-paths, the flame cools down and the combustion product is not able to trigger the mixture present outside (held at flame). When choosing the "Ex d" protection method, the following indications have to be considered:

- do not make further holes in the junction boxes than those allowed in the certificate;
- if the cable entry has a parallel thread, the coupling must have at least 5 full threads;
- if the use of gasket is foreseen, the number of threads must be still sufficient after the insertion of the gasket;
- if the thread is conical, the connection must be fully tightened;
- if an adapter is required, it must comply with the "Ex d" (IEC 60079-1) protection method;
- the unused cable entries must be sealed with elements that comply with "Ex d" protection method (IEC 60079-1).

	1	2	3
G	Zone 0	Zone 1	Zone 2
D	Zone 20	Zone 21	Zone 22

Tab.3 Correlation between equipment category and installation area for Group II

	M1	M2	1G	2G	3G
			1D	2D	3D
	Ma	Mb	Ga	Gb	Gc
			Da	Db	Dc

Tab.4 Correlation between equipment category and the protection level

## TEMPERATURE CLASSES

The temperature class is one of the parameters to consider in order to choose electrical equipment to be installed in places with danger of explosion.

Very often this parameter is ignored or underestimated while it's one of the main features of the safety equipment.

An electrical device, addressed to classified areas where there might be danger of explosion due to the presence of gases, vapours, mists or dusts, should be chosen considering that, its maximum surface temperature, must not reach, even in case of failure, the ignition temperature of the hazardous substances present in the atmosphere.

### • Temperature classes for Gas

A standard method of classification defines the temperature classes of a gas. This standard, defined by IEC, but also acknowledged by CENELEC, is held in IEC 60079-4 Standard "Method of testing ignition temperatures". According to this method, all gases and vapours are divided into temperature classes. According to these classes, the equipment maximum surface temperature reached is always lower than the ignition temperature.

The Standard defines in detail the maximum values and the necessary safety net for these temperatures.

Temperature class	Gas group ignition temperature	Equipment max. surface temperature
T1	> 450 °C	400 °C
T2	> 300 ... ≤ 450 °C	300 °C
T3	> 200 ... ≤ 300 °C	200 °C
T4	> 135 ... ≤ 200 °C	135 °C
T5	> 100 ... ≤ 135 °C	100 °C
T6	> 85 ... ≤ 100 °C	85 °C

Tab.5 Temperature classes

# Appendix

## IP PROTECTION RATINGS (IEC 529, EN 60529-4, CEI 70-1 ed. 11/92)

The table gives protection ratings in accordance with standard CEI 70-1 ed. 11/92. Ratings are identified by the acronym IP followed by 2 digits, to which 2 letters may be added, indicating the degree to which persons are protected against access or other properties. There is some variation in the application of ratings 7 and 8 relating to the ingress of liquids, with these ratings not always meaning that the item is suitable for lower levels (whereas IP rating x4 also covers the lower levels).

## IMPACT PROTECTION RATINGS

This classification shows the acceptable level of strength, when evaluating a product's safety, and is mainly employed in relation to testing on electromechanical products.

1st Digit PROTECTION AGAINST SOLID BODIES	2nd Digit PROTECTION AGAINST LIQUIDS	PROTECTION AGAINST EXTERNAL MECHANICAL IMPACTS *
<b>0</b> No protection	<b>0</b> No protection	<b>IK00</b> No protection
<b>1</b> Protected against solid bodies greater than 50 [mm]	<b>1</b> Protected against vertically falling water drops	<b>IK01</b> 0,25 Kg, 5,6 cm Protected against impact energy 0,15J
<b>2</b> Protected against solid bodies greater than 12 [mm]	<b>2</b> Protected against falling water drops with maximum inclination 15°	<b>IK03</b> 0,25 Kg, 14 cm Protected against impact energy 0,35J
<b>3</b> Protected against solid bodies greater than 2,5 [mm]	<b>3</b> Protected against rain	<b>IK05</b> 0,25 Kg, 28 cm Protected against impact energy 0,7J
<b>4</b> Protected against solid bodies greater than 1 [mm]	<b>4</b> Protected against sprinkles	<b>IK06</b> 0,25 Kg, 40 cm Protected against impact energy 1J
<b>5</b> Protected against dust	<b>5</b> Protected against water splashes from every directions	<b>IK07</b> 0,5 Kg, 40 cm Protected against impact energy 2J
<b>6</b> Totally protected against dust	<b>6</b> Protected against strong water splashes (waves)	<b>IK08</b> 1,7 Kg, 30 cm Protected against impact energy 5J
<b>ADDITIONAL LETTER**</b>	<b>7</b> Protected against temporal immersion	<b>IK09</b> 5 Kg, 20 cm Protected against impact energy 10J
<b>A</b> Protected against access with the back of the hand	<b>8</b> Protected against continuous immersion	<b>IK10</b> 5 Kg, 40 cm Protected against impact energy 20J
<b>B</b> Protected against access with a finger		
<b>C</b> Protected against access with a tool		
<b>D</b> Protected against access with a wire		
<b>OPTIONAL LETTER</b>		
<b>H</b> High-voltage device		
<b>M</b> Tested against the harmful effects of water ingress with the equipment running		
<b>S</b> Tested against the harmful effects of water ingress with the equipment not running		
<b>W</b> Suitable for use in specified atmospheric conditions		

\* As per IEC EN 50102: 1996-05; IEC EN 60078-2-7-5: 1998-09.

\*\* Optional letter describing protection against access by persons. Only used if protection against access to hazardous parts is greater than that indicated by the first digit, or if only protection against access to hazardous parts is given and an X is used in place of the first digit.

## MATERIAL USED

We use many different materials to produce equipment and components designed for areas with a potentially explosive atmosphere. Despite the careful choice of these materials to be transformed into finished products, we have to take into account the limitations imposed by nature.

All materials, including the ones we use, have three enemies:

- environment;
- temperature;
- time.

Temperature and time are familiar factors, while the environment, where our products are used, is not easy to control.

We are not talking about familiar potential hazards caused by an explosive atmosphere (which can be controlled by laboratory tests and guaranteed by certification), but rather deterioration caused by highly aggressive environments like chemical and petrochemical plants.

Corrosion resistance is a relative factor, as it depends on the actual environmental conditions that significantly influence the nature of the attack. Shown below are described the materials mainly used by ELFIT for the production of cable glands and electrical fittings.

## NICKEL-PLATED BRASS

We use this material (leaded brass with Cu 58%, Zn 40% and Pb 2%) exclusively for the construction of Ex cable entry (Cable glands). Besides the traditional copper (Cu) and zinc (Zn) alloy, our material has also a low lead (Pb) percentage on the external part of the bar, which simplifies the turning since it does not create a solution with the alloy Cu-Zn, and since it has a lower solidification temperature than the other two elements. Subsequently, it undergoes a surface treatment of electrolytic nickel plating, to provide the product, more than with an aesthetic aspect, with a higher corrosion-protection level by external agents.

## ALUMINIUM ALLOY

Aluminium alloy is one of the world's most widely used materials in the production of explosion-proof enclosures.

It is highly corrosion-resistant and, therefore, universally known as the most effective and versatile material for most applications.

It is much lighter than cast iron, so it makes the equipment much easier to install and maintain; moreover, it is highly corrosion-resistant and does not require surface protection, unlike cast iron which has to be galvanized or coated.

Aluminium is also much cheaper than stainless steel.

Aluminium and its alloys have generally excellent corrosion resistance in various and different environments.

Despite of it's a very chemically active metal, its behavior is stabilized by the formation of a protective oxide film on its surface.

This film, which in case of breakage is able to reproduce itself immediately, has a thickness, if formed in the air, ranging from 50

	Fe	Si	Mn	Ni	Ti	Cu	Pb	Mg	Zn	Sn	Other
<b>AlSi10Mg(a)</b>	max 0,55	9 ÷ 11	max 0,45	max 0,05	max 0,15	max 0,05	max 0,05	0,2 ÷ 0,45	max 0,1	max 0,05	each 0,05; total 0,15
<b>AlSi12(b)</b>	max 0,65	10,5 ÷ 13,5	max 0,55	max 0,1	max 0,2	max 0,15	max 0,1	max 0,1	max 0,15	//	each 0,05; total 0,15

Tab. 6 Chemical composition of aluminum-silicon alloys

to 100 A.



# Appendix

## STAINLESS STEEL

The stainless steels are iron-, coal- and chrome-based alloys that combine the mechanical properties typical of carbon steels with the corrosion resistance properties, due to a thin and transparent surface layer called "passivation layer". It is formed when the materials of the alloy come into contact with the air or water oxygen.

This phenomenon in stainless steel, in ideal conditions, occurs naturally and immediately.

This protection can also be artificially and optimally induced carrying out a particular chemical treatment by immersing the products in sequence, first in pickling acid and, subsequently, in a passivating acid. This treatment enhances very significantly the corrosion resistance, making this invisible layer, which has the thickness of a few atoms (about 0.002 microns) and which reform spontaneously, an excellent barrier to oxidation and corrosion. Essential condition for the formation of a protective layer is the presence of a sufficient amount of chromium.

The stainless steels are traditionally divided into three big families, depending on their metallographic structure:

- martensitic;
- ferritic;
- austenitic.

Austenitic steels, which are usually used for the construction of electrical equipment, suitable for environments with risk of explosion and in the presence of aggressive substances, are mainly:

- AISI 304 It's a founder of austenitic stainless steels. It has good corrosion resistance and good mechanical characteristics. Used in the pharmaceutical and food industries.
- AISI 304L It differs from AISI 304 for the low carbon content ( $C \leq 0,03\%$ ), which considerably increases the resistance to corrosion. Because of the low carbon content of the mechanical characteristics, they are slightly inferior to AISI 304 ones.
- AISI 316 Compared to AISI 304 contains molybdenum with percentage of about 2,5% and a higher percentage of nickel. These elements give to the steel superior mechanical characteristics and a higher resistance to corrosion at high temperatures. Used in the processes of machining and of installations in contact with seawater.
- AISI 316L It differs from AISI 316 for the low carbon content ( $C \leq 0,03\%$ ). It has a better corrosion resistance maintaining good mechanical characteristics. Used for the construction of electrical equipment and for the construction of distribution panels in environments with explosion risk and the presence of gases or dusts, corrosive agents and high temperatures.

## GALVANIZED STEEL

We use even this type of material, an iron (Fe) carbon (C) alloy, as well as nickel-plated brass, for connection elements of Ex entries. It is a stainless steel, sweet, for general use, with small amounts of lead, bismuth, tellurium or sulfur.

To protect the component from corrosion, at the end of machining it undergoes a galvanizing process.

## SILICONE

The silicone, as well as the neoprene, is one of main materials we use for our seals. Silicones or polysiloxanes (methylvinyl polysiloxane) are inorganic polymers based on a silicon-oxygen chain and organic functional groups (R) linked to the silicon atoms. Typically, the silicone rubbers (VMQ) are remarkably resistant to temperature, chemical attack and oxidation, and are excellent electrical insulators. They are excellent non-stick, flexible, resistant to aging and to high temperatures.





### **Modifiche prodotti e garanzia**

Cortem Group si riserva il diritto di apportare (in ogni momento e senza obbligo di preavviso) tutte le modifiche che, a proprio insindacabile giudizio, ritenesse opportune per migliorare la funzionalità e la prestazione dei prodotti, nonché per rispondere a proprie esigenze tecniche e produttive. Le indicazioni delle misure, dei disegni, dei prodotti e dei componenti sono riportate a titolo informativo e non hanno alcun carattere vincolante essendo possibile la loro modifica senza alcun preavviso.

Le informazioni, i dati tecnici e i certificati più aggiornati dei nostri prodotti sono disponibili consultando il sito [www.cortemgroup.com](http://www.cortemgroup.com)

Tutti i prodotti Cortem Group sono coperti da garanzia per un periodo di 12 mesi dalla data di consegna. Per maggiori informazioni, consultare le "Condizioni Generali di Vendita" sul sito [www.cortemgroup.com](http://www.cortemgroup.com).

### **Copyright**

A norma della legge sul diritto d'autore, del Codice Civile Italiano e delle ulteriori disposizioni in vigore nei mercati sui quali Cortem Group opera, ogni informazione, immagine, fotografia, disegno, tabella e quant'altro contenuto nel materiale illustrativo/promozionale Cortem Group è di proprietà esclusiva di Cortem Group, che ne detiene ogni diritto morale e di sfruttamento commerciale ed economico. E' pertanto vietata ogni riproduzione, con qualunque mezzo, totale e/o parziale, del materiale illustrativo/promozionale Cortem Group, salvo espresso consenso scritto di Cortem Group stessa. Ogni violazione di quanto sopra, verrà perseguita ai sensi di legge.

© di Cortem - Villesse - Italia. Tutti i diritti riservati





Via Aquileia 12  
34070 Villesse (GO), Italia  
tel. +39 0481 964911 r.a.  
fax +39 0481 964999  
info@elfit.com  
vendite@elfit.com  
www.elfit.com

CATELFIT12/23 - K250  
Print: GRAFICA GORIZIANA  
Copyright 2022 Cortem Design