

Cortem STREETEX series lighting fixture

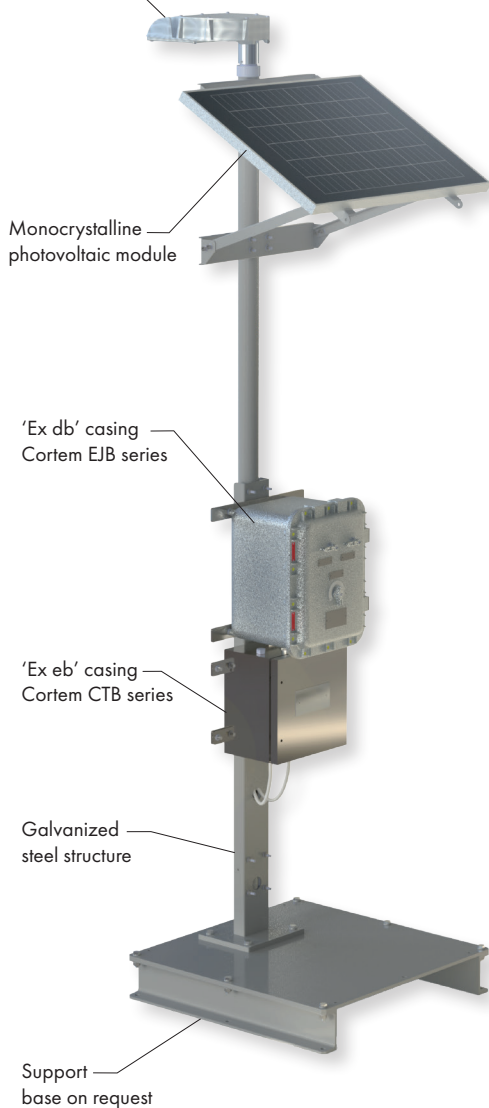

### SOLAREx series standalone unit

SolarEx is a standalone energy storage system capable of powering a utility in areas at risk of explosion and fire classified as Zone 1.

The SolarEx prototype is designed to power a STREETEX-M series lighting fixture for at least 8 hours using a photovoltaic panel and an appropriately sized battery pack. It operates in the same way as a standard solar-powered system: the photovoltaic panel captures solar energy that is converted and stored in the battery pack, which in turn powers the light source. The system is equipped with a device that only allows the lighting fixture to switch on at night, making it as efficient as possible.

**Certification:** ATEX and IEC Ex  
**Marking:** Ex db eb mb IIC; Ex tb IIIC  
**Ambient temperature:** -20°C +55°C  
**Degree of protection:** IP66

**Lighting fixture:** STREETEX-ME-080...  
**Material:** Aluminium alloy with low copper content. With cooling fins for efficient heat dissipation.

**Coating:** Polyester RAL 7035.

**Casing Ex db:** EJB-4  
**Material:** Body and lid in low copper content aluminium alloy. Hinges in stainless steel.

**Coating:** Polyester RAL 7035.

**Casing Ex eb:** CTB303020  
**Material:** Body and lid in stainless steel AISI 316L. Hinges in stainless steel AISI 316L.

**Load-bearing structure in hot-dip galvanized steel.**

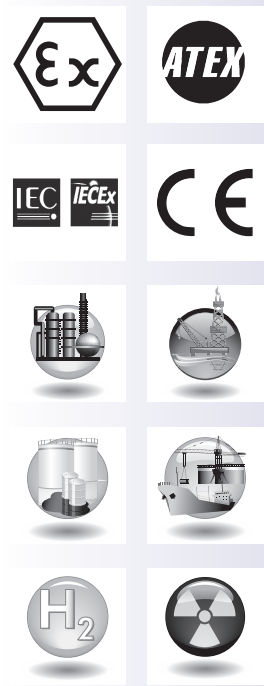

Technical specifications	Models	
	SOLAREx25	SOLAREx50
Lamp power	25 W	50 W
Hours of operation	8 h	8 h
Total load	200 Wh/day	400 Wh/day
Solar panel peak power	70 Wp	200 Wp
Battery capacity	32 Ah	85 Ah
Batteries rated voltage	24 Vdc	24 Vdc

**Technical tips:** Knowing the side on which the sunlight is strongest is a priority, as panels are more productive when the sun's rays are perpendicular to their surface.

Install the solar module in a south-facing (northern hemisphere) or north-facing (southern hemisphere) position where possible and ensure it is optimally positioned with respect to the winter sun to maximise energy yield. Clean the module regularly to maintain its efficiency. Dirty or obscured solar modules generate less electricity.

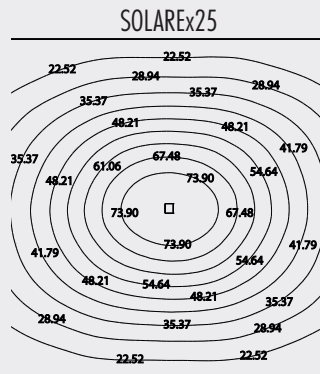
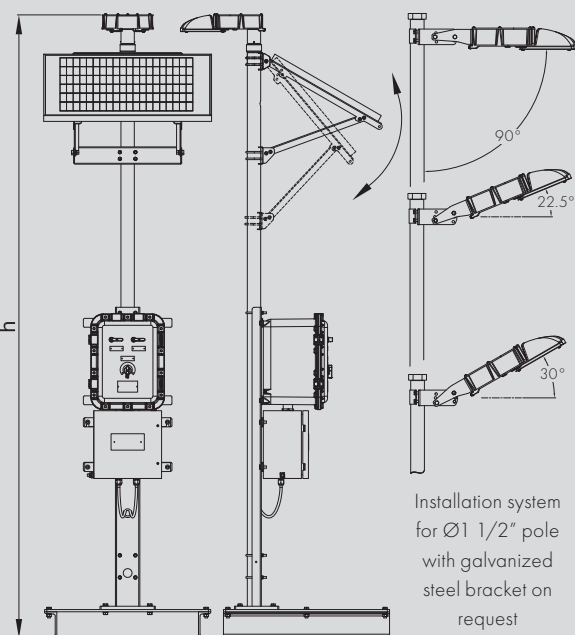

Floor lighting relating to SOLAREx25 system expressed in lux with fixture at a height of **3 m**.

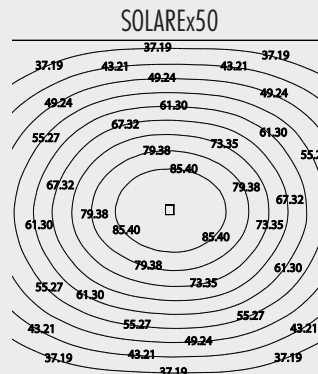

Floor lighting relating to SOLAREx50 system expressed in lux with fixture at a height of **4 m**.

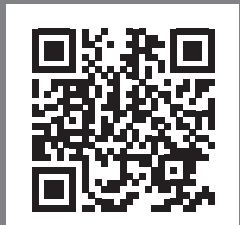

### COMPONENTS INSTALLED IN DETAIL

#### STREETEX lighting fixture



STREETEX series LED lighting fixtures are suitable for outdoor and perimeter street lighting of industrial areas, especially for the chemical and petrochemical, on-shore and off-shore sectors. Optics is a crucial part of street lighting as it determines the direction of light on the road surface according to different requirements: light concentrated in a specific direction or evenly diffused light.

Code	Real power Watt	Rated power Watt	Lumen lm	Light intensity cd	Overall efficiency Lm/W
STREETEX-ME-080025...	26	25	3432	1079	132
STREETEX-ME-080050...	52	50	6865	2159	132

#### Available optical features

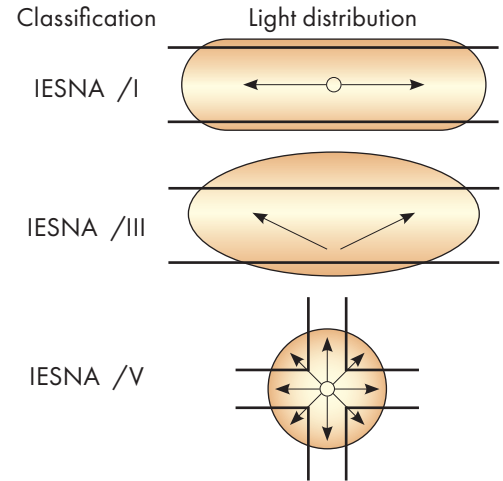

#### PFV-Ex monocrystalline photovoltaic module

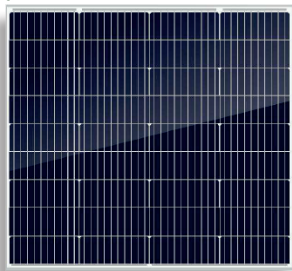

The PFV-Ex series is a range of photovoltaic panels that can be used in hazardous areas 1, 2, 21 and 22. The solar panel converts the sun's rays into energy in the form of continuous electricity to be stored in a battery pack or used to power certain electronic devices.

The type of protection used to guarantee the safety of the solar panels is 'Ex m' encapsulation, which consists in encapsulating the part that could ignite an explosive atmosphere using a certain compound. The high purity of the silicon crystal allows monocrystalline panels to generate a considerable amount of electricity even in low light conditions. This

ensures the photovoltaic panel can keep generating electricity even on cloudy days, allowing the battery to charge more efficiently.

#### Features

Solar cell	Monocrystalline	Module efficiency	19.02%
Power tolerance (Pmax)	0 ~ +3%	Fuse rated current	10 A
Number of cells	36 cells in series		
Module dimensions	758x555x35 mm		
Weight	5.5 Kg		

Max power (Pmax)	80Wp
Peak operating voltage (Vmp)	20.4 V
Current at max power (Imp)	3.93A
Open-circuit voltage (Voc)	24.3 V
Short-circuit current (Isc)	4.19A

#### Irradiance

Current and voltage output as a function of irradiance

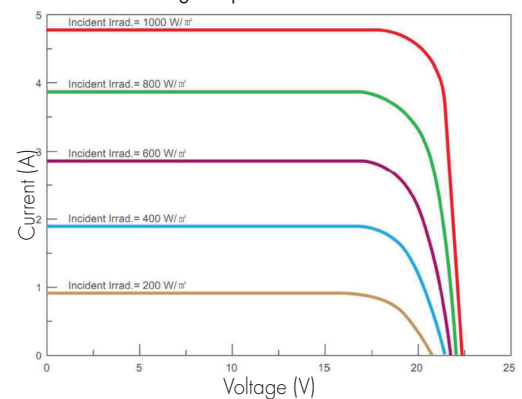

#### Control system

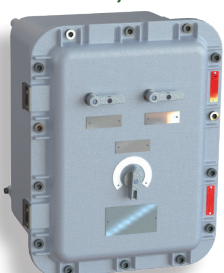

System voltage	24 V
Power 30 min.	275 VA
Power 5 sec.	450 VA

#### Features

- Excellent overload performance
- Optimum battery protection
- High efficiency MPPT solar charge controller
- Deep discharge protection
- Battery surge lockout
- Overheat and overload protection
- Short-circuit protection
- Deep discharge or overheat audible alarm
- Main switch
- Settable charge recognition

#### Storage system

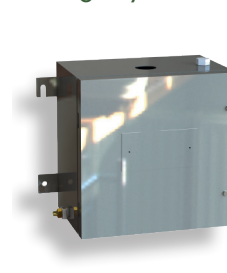

#### Features

- Excellent performance: 800 cycles at 60% charge C10 (at 20 °C)
- Dryfit gel: VRLA technology
- Low energy consumption: cost saving
- Fully recyclable

- Rated capacity 6.60 – 230 Ah C100 (20 °C)
- Long shelf life of up to 2 years at 20 °C without recharging due to very low self-discharge rate
- Made in Europe at ISO 9001 certified facilities

Lamp power	..x25	..x50
Rated voltage	24 V	24 V
Rated capacity C100 1.80Vpc 20 °C	32.0 Ah	85.0 Ah
Discharge current I100	0.32 A	0.85 A